

150W FAN COOLED | 110W CONVECTION COOLED

AC-DC POWER SUPPLIES

The GCS150 is a series of medical AC-DC power supplies with 150W fan cooled and 110W convection rating.

Designed to minimize no load power consumption, the GCS150 series of high efficiency, single-output power supplies are packaged in an industry standard 5.0" x 3.0" x 1.42" package making them suitable for medical, industrial, information technology and domestic applications. Class I and Class II versions are available, allowing use in professional healthcare facilities such as hospitals and remotely in patients' homes or workplaces.

With a wide range of international medical safety and ITE approvals, class B compliance for conducted and radiated emissions, very low earth leakage currents, and 2 x MOPP protection, the GCS150 benefits system designers with easy integration into a wide range of applications.



Features

- Single outputs from 12V to 48VDC
- Universal 85 to 264VAC input range
- ITE and medical safety approvals (Class I & II)
- <0.5W standby power
- Class B emissions
- Remote on/off optional
- Overcurrent, overvoltage and short-circuit protection
- Operating temperature range from -40°C to +70°C
- 3 year warranty

Models & Ratings

Model Number ^(1,2,3,4)	Output Voltage V1	Output Current V1		Output Voltage (Vfan) & Current	Max Output Power
		Convection-cooled	Forced-cooled ⁽⁵⁾		
GCS150PS12	12.0VDC	9.2A	12.5A	12.0VDC/0.6A	157W
GCS150PS15	15.0VDC	7.3A	10.0A	12.0VDC/0.6A	157W
GCS150PS24	24.0VDC	4.6A	6.3A	12.0VDC/0.6A	157W
GCS150PS28	28.0VDC	3.9A	5.4A	12.0VDC/0.6A	157W
GCS150PS48	48.0VDC	2.3A	3.2A	12.0VDC/0.6A	157W

Notes:

1. Add suffix -C for convection-cooled cover, e.g. GCS150PS12-C.
2. Cover kits available. Order part no.: GCS150/180 CVR KIT
3. Add suffix -EF for fan-cooled cover with end fan e.g. GCS150PS12-EF, add suffix -TF for fan-cooled cover with top fan, e.g. GCS150PS12-TF. Note: Vfan output no longer available.
4. Add suffix -R for remote on/off, e.g. GCS150PS12-R, GCS150PS12-RC with convection cover or GCS150PS12-REF/GCS150PS12-RTF with fan covers.
5. 7 CFM required to meet stated current for GCS150.

Applications



Healthcare



Home Healthcare



Industrial Electronics



Instrumentation



Technology

Dimensions

GCS150:

5.00 x 3.00 x 1.42" (127.0 x 76.2 x 36.3mm)
 (-C): 5.50 x 3.48 x 1.70" (139.7 x 88.5 x 43.2mm)
 (-TF): 5.50 x 3.48 x 2.20" (139.7 x 88.5 x 57.8mm)
 (-EF): 6.35 x 3.48 x 1.70" (161.3 x 88.5 x 43.2 mm)

Summary

Characteristic	Minimum	Typical	Maximum	Units	Notes & Conditions
Input Voltage Range	85	115/230	264	VAC	Derate output power at <90VAC. See fig. 1
No Load Input Power		2.3	0.5	W	All models including -R models -R models with inhibit activated
Efficiency	80 plus silver 80 plus bronze	93		%	230VAC Full load (see fig.3-5) All models except 12V models 12V models
Operating Temperature	-40		+70	°C	See derating curve, fig. 8
EMC	EN55011/32 Level B Conducted & Radiated, EN61000-3-3				
Safety Approvals	IEC60950-1, IEC60601-1, UL62368-1, CAN/CSA C22.2 No. 62368-1-14, ANSI/AAMI ES60601-1, CSA C22.2, No.60601-1, EN62368-1, EN60601-1				

Input

Characteristic	Minimum	Typical	Maximum	Units	Notes & Conditions
Input Voltage Range	85	115/230	264	VAC	Derate output power <90VAC. See fig. 1
Input Frequency	47	50/60	63	Hz	
Power Factor		>0.9			230VAC, 100% load
Input Current - Full Load		1.5/0.7		A	115/230VAC
Inrush Current		80		A	230VAC, cold start 25°C
Earth Leakage Current		60/120	200	µA	115/230VAC/50Hz Typ., 264VAC/60Hz max.
No Load Input Power		2.3	0.5	W	All models including -R models -R models with inhibit activated
Input Protection	F3.15 A/250 V internal fuse in both lines				

Input Voltage Derating Curve

Figure 1

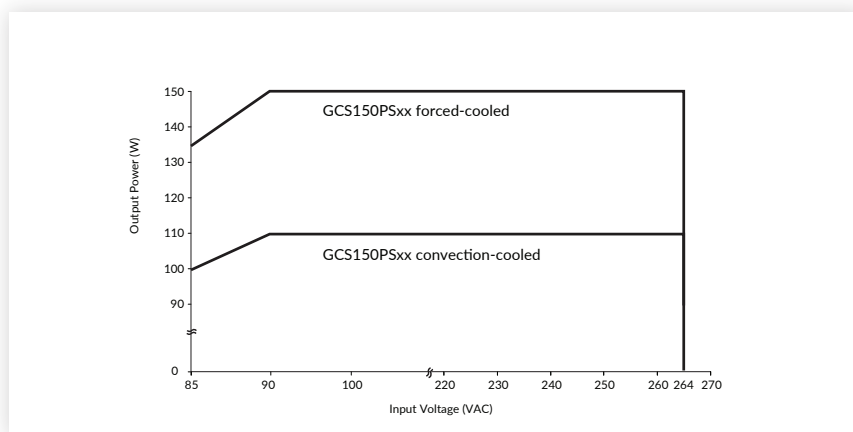

Output

Characteristic	Minimum	Typical	Maximum	Units	Notes & Conditions
Output Voltage - V1	12		48	VDC	See Models & Ratings table
Initial Set Accuracy			$\pm 1^{(V1)}$ & $\pm 5^{(Vfan)}$	%	50% load, 115/230VAC
Output Voltage Adjustment - V1			± 2	%	Via potentiometer. See mech. details, Vfan will track
Minimum Load	0			A	No minimum load required
Start Up Delay			2	s	115/230VAC, full load
Hold Up Time		20		ms	
Drift			± 0.2	%	After 20 min warm up
Line Regulation			± 0.5	%	90-264VAC
Load Regulation			$\pm 0.5^{(V1)}$, $\pm 5^{(Vfan)}$	%	0-100% load
Transient Response - V1			4	%	Recovery within 1% in less than 500 μ s for a 50-75% and 75-50% load step
Over/Undershoot -V1		0		%	
Ripple & Noise -V1			1	% pk-pk	20MHz bandwidth, 12V models 1.5% max.
Overvoltage Protection - V1	110		140	%	Vnom DC. Output 1, recycle input to reset
Overload Protection - V1	110		150	% I nom	See fig. 2. Trip & restart
Short Circuit Protection - V1					Continuous
Temperature Coefficient			0.05	%/°C	

Output Overload Characteristic

Figure 2
GCS150PS12 example (others similar)

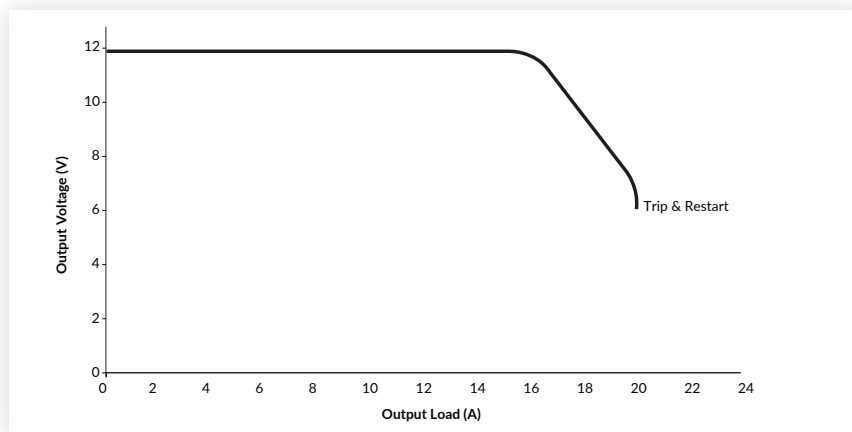

General

Characteristic	Minimum	Typical	Maximum	Units	Notes & Conditions
Efficiency		93		%	230VAC Full load (see fig.3-5)
	80 plus silver				All models except 12V models
	80 plus bronze				12V models
Isolation: Input to Output	4000			VAC	
Input to Ground	1500				
Output to Ground	1500				
Switching Frequency	60		200	kHz	PFC
	90		150		Main converter
Power Density			7.4	W/in ³	
Mean Time Between Failure		569		khrs	MIL-HDBK-217F, Notice 2 +25°C GB
Weight		0.65 (0.29)		lb (kg)	Open frame
		1.30 (0.59)			End fan unit
		1.15 (0.52)			Top fan unit
		1.05 (0.48)			Covered unit

Efficiency Graphs

Efficiency vs Load

Figure 3
GCS150PS12

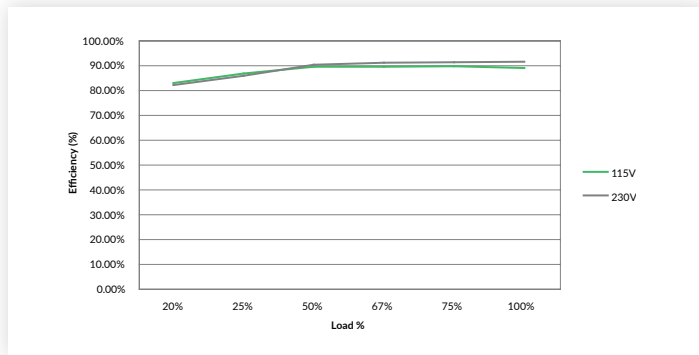

Figure 4
GCS150PS24

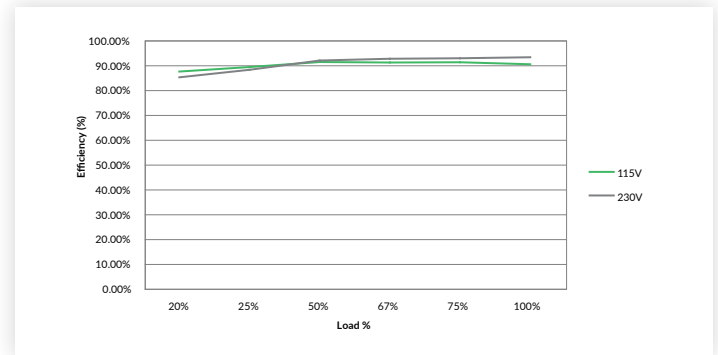
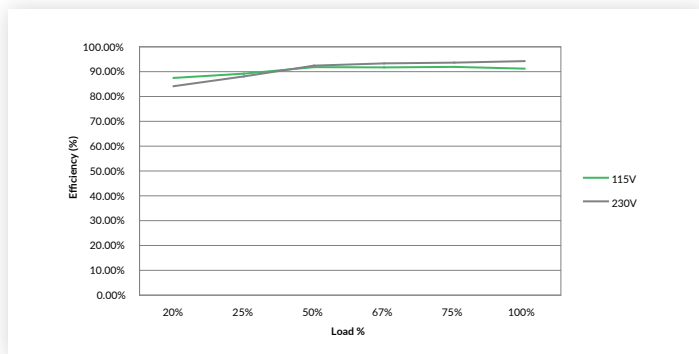

Figure 5
GCS150PS48



Signals & Controls

Characteristic		Notes & Conditions
Remote Sense		Compensates for 0.5V total voltage drop
Remote On/Off (-R models)	Inhibit	The inhibit lo (pin 4), should be pulled below 0.4V to switch V1 & Vfan off. Open circuit or >4V to switch on (see fig. 6)
	Enable	With the inhibit lo (pin 4) pulled low as detailed above, connecting inhibit hi (pin 5) to inhibit lo (pin 4) will enable V1 & V fan output. (see fig. 7)

Remote On/Off (Inhibit)

Figure 6

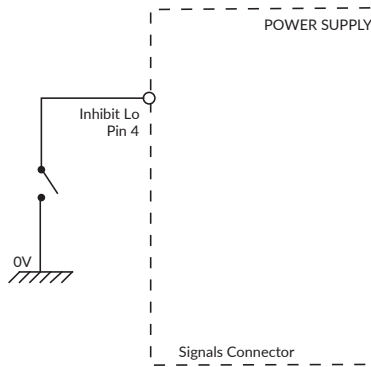

Remote On/Off (Enable)

Figure 7

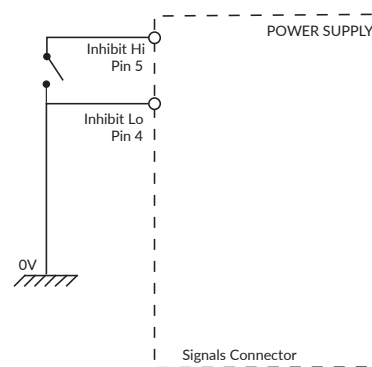

Environmental

Characteristic	Minimum	Typical	Maximum	Units	Notes & Conditions
Operating Temperature	-40		+70	°C	See derating curve, fig. 8
Storage Temperature	-40		+85	°C	
Cooling	7			CFM	Force cooled >110W
Humidity	5		95	%RH	Non-condensing
Operating Altitude			5000	m	
Shock	±3 x 30g shocks in each plane, total 18 shocks. 30g = 11ms (±0.5msec), half sine. Conforms to EN60068-2-27 & EN60068-2-47				
Vibration	Single axis 10-500 Hz at 2g sweep and endurance at resonance in all 3 planes. Conforms to EN60068-2-6				

Temperature Derating Curve

Figure 8 - Convection cooled ratings

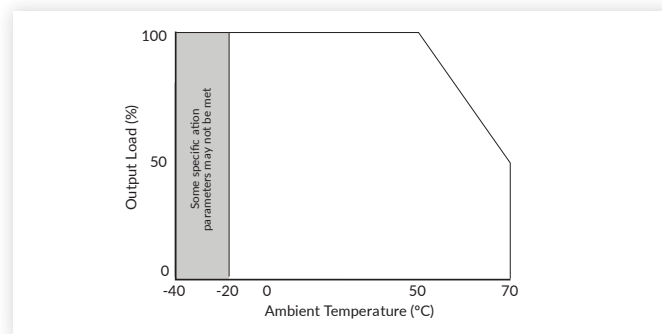

EMC: Emissions

Phenomenon	Standard	Test Level	Notes & Conditions
Conducted	EN55011/32	Class B	
Radiated	EN55011/32	Class B	
Harmonic Fluctuations	EN61000-3-3		

EMC: Immunity

Phenomenon	Standard	Test Level	Criteria	Notes & Conditions	
Low Voltage PSU EMC	EN61204-3	High severity level	as below		
Harmonic Current	EN61000-3-2	Class A	A	All models	
		Class C		>50W	
Radiated	EN61000-4-3	3	A		
EFT	EN61000-4-4	3	A		
Surges	EN61000-4-5	Installation class 3	A		
Conducted	EN61000-4-6	3	A		
Dips and Interruptions	EN55035 (100VAC)	Dip >95% (0VAC), 8.3ms	A		
		Dip 30% (70VAC), 416ms	B		
		Dip >95% (0VAC), 4160ms	B		
	EN55035 (240VAC)	Dip >95% (0VAC), 10.0ms	A		
		Dip 30% (168VAC), 500ms	B		
		Dip >95% (0VAC), 5000ms	B		
	EN60601-1-2 (100VAC)	Dip >95% (0VAC), 10.0ms	A		
		Dip 60% (40VAC), 100ms	A		Derate Output Power to 85W
		Dip 30% (70VAC), 500ms	A		
	EN60601-1-2 (240VAC)	Dip >95% (0VAC), 5000ms	B		
		Dip >95% (0VAC), 10.0ms	A		
		Dip 60% (96VAC), 100ms	A		
		Dip 30% (168VAC), 500ms	A		
		Dip >95% (0VAC), 5000ms	B		

Safety Approvals

Certification	Standard	Notes & Conditions
CB	IEC60950-1:2005 Ed 2 / IEC62368-1:2014	Information Technology
	IEC60601-1 Ed 3.1 Including Risk Management	Medical
UL	UL62368-1 & CAN/CSA C22.2 No. 62368-1-14	Information Technology
	ANSI/AAMI ES60601-1:2005 & CSA C22.2, No.60601-1:08	Medical
TUV	EN62368-1:2014/A11:2017	Information Technology
	EN60601-1/A12:2016	Medical
Equipment Protection Class	Class I & Class II	See safety agency conditions of acceptability for details
CE	Meets all applicable directives	
UKCA	Meets all applicable legislation	
Isolation	Means of Protection	Category
Primary to Secondary	2 x MOPP (Means of Patient Protection)	IEC60601-1
Primary to Earth	1 x MOPP (Means of Patient Protection)	IEC60601-1
Secondary to Earth	1 x MOPP (Means of Patient Protection)	IEC60601-1

Mechanical Details

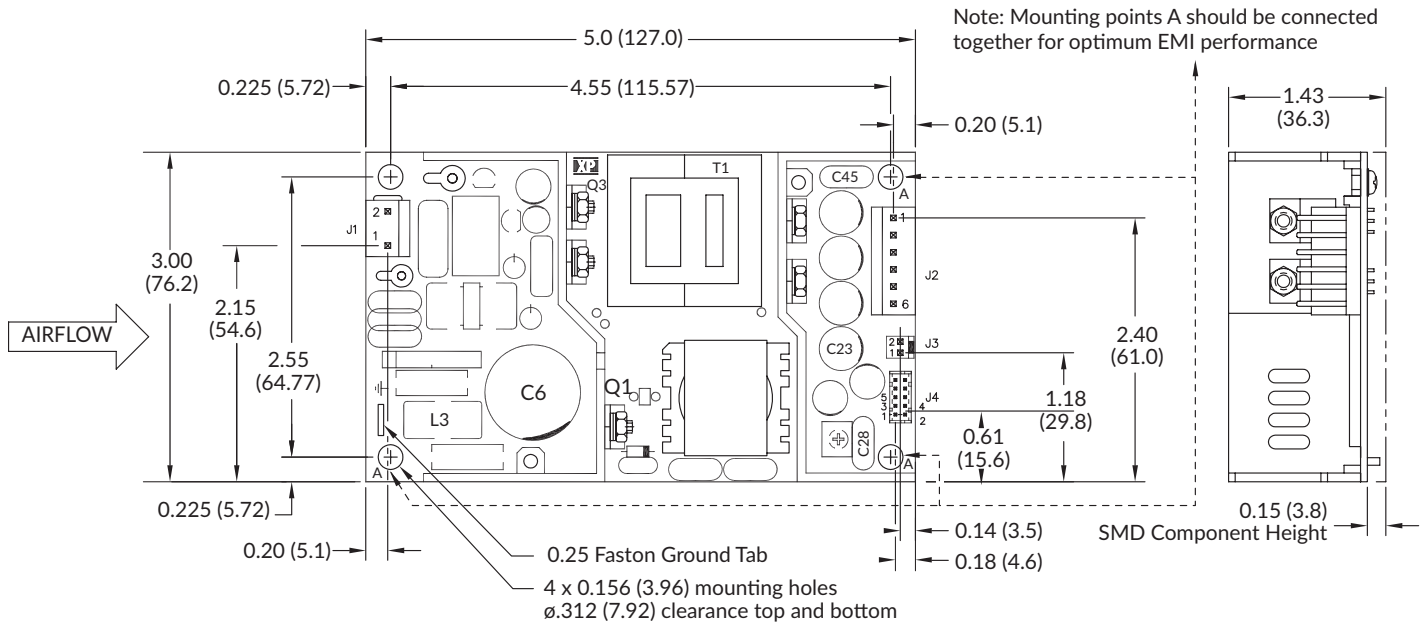

Input Connector J1 Molex pn. 09-65-2038	
Pin	Function
1	Line
2	Neutral

Output Connector J2 Molex pn. 09-65-2068	
Pin	Function
1	+V1
2	+V1
3	+V1
4	RTN
5	RTN
6	RTN

Fan Connector J3 Molex pn. 22-04-1021	
Pin	Function
1	Fan + (12V)
2	Fan -

Signal Connector J4 JST PN B10B-PHDSS			
Pin	Function	Pin	Function
1	+Sense	7	N/C
2	-Sense	8	N/C
3	XP Internal Use	9	N/C
4	Inhibit LO	10	N/C
5	Inhibit HI		
6	N/C		

Notes:

- All dimensions in inches (mm).
- Tolerance .xx = ±0.02 (0.50); .xxx = ±0.01 (0.25)
- Weight: 0.65 lbs (0.29 kg)
- J1 mates with Molex Housing Pn. 09-50-1031. J2 mates with Molex Housing Pn. 09-50-1061 and both with Molex series 5194 crimp terminals. J4 mates with JST

Housing Pn. PHDR-10VS and with JST SPHD-001T-P0.5 crimp terminals. J3 mates with Molex Housing Pn. 51191-0200 and with Molex series 50802 crimp terminals.

Mechanical Details

Covered Version (-C suffix)

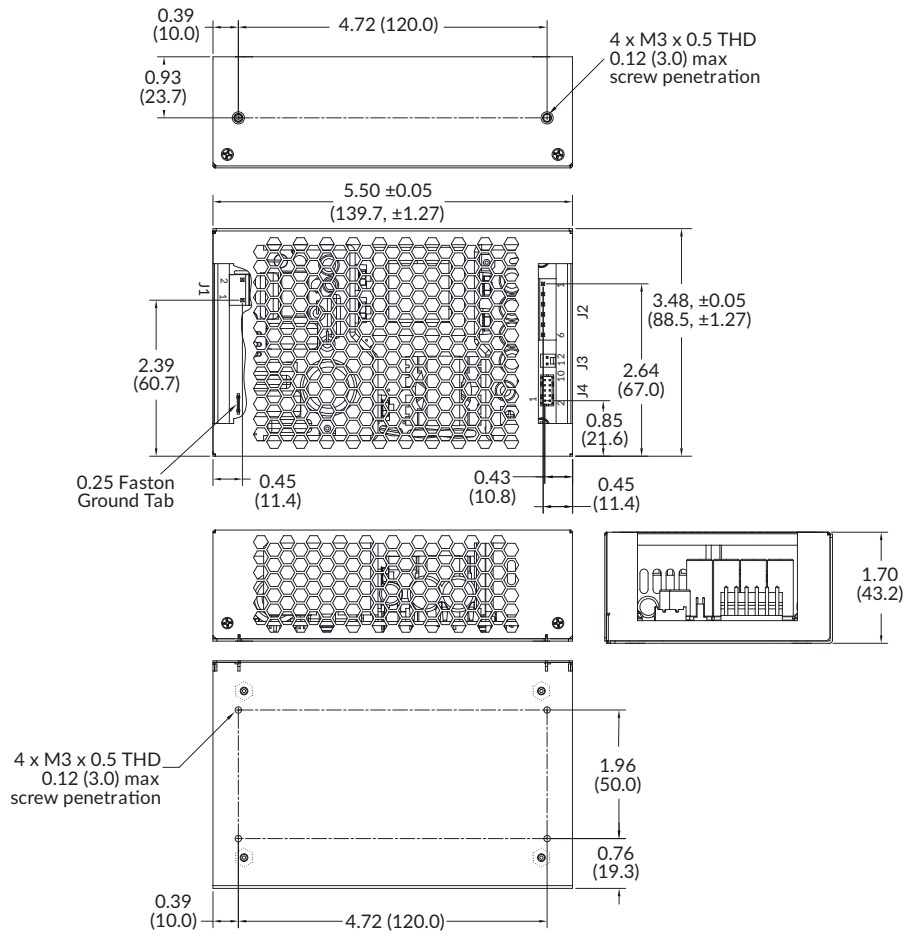

Input Connector J1 Molex pn. 09-65-2038	
Pin	Function
1	Line
2	Neutral

Output Connector J2 Molex pn. 09-65-2068	
Pin	Single Output
1	+V1
2	+V1
3	+V1
4	RTN
5	RTN
6	RTN

Fan Connector J3 Molex pn. 22-04-1021	
Pin	Function
1	Fan + (12V)
2	Fan -

Signal Connector J4 JST PN B10B-PHDSS			
Pin	Function	Pin	Function
1	+Sense	7	N/C
2	-Sense	8	N/C
3	XP Internal Use	9	N/C
4	Inhibit LO	10	N/C
5	Inhibit HI		
6	N/C		

Notes:

- All dimensions in inches (mm).
- Tolerance .xx = 0.02 (0.50); .xxx = 0.01 (0.25)
- J1 mates with Molex Housing Pn. 09-50-1031. J2 mates with Molex Housing Pn. 09-50-1061 and with Molex series 5194 crimp terminals. J4 mates with JST Housing

- Pn. PHDR-10VS and with JST SPHD-001T-P0.5 crimp terminals. J3 mates with Molex Housing Pn. 51191-0200 and with Molex series 50802 crimp terminals.
- In class II installations the cover is floating and provides 1 x MOPP (2 x MOOP).
- Weight: 1.05lbs (0.48kg)

GCS150 Series

Mechanical Details

Top Fan Version (-TF suffix)

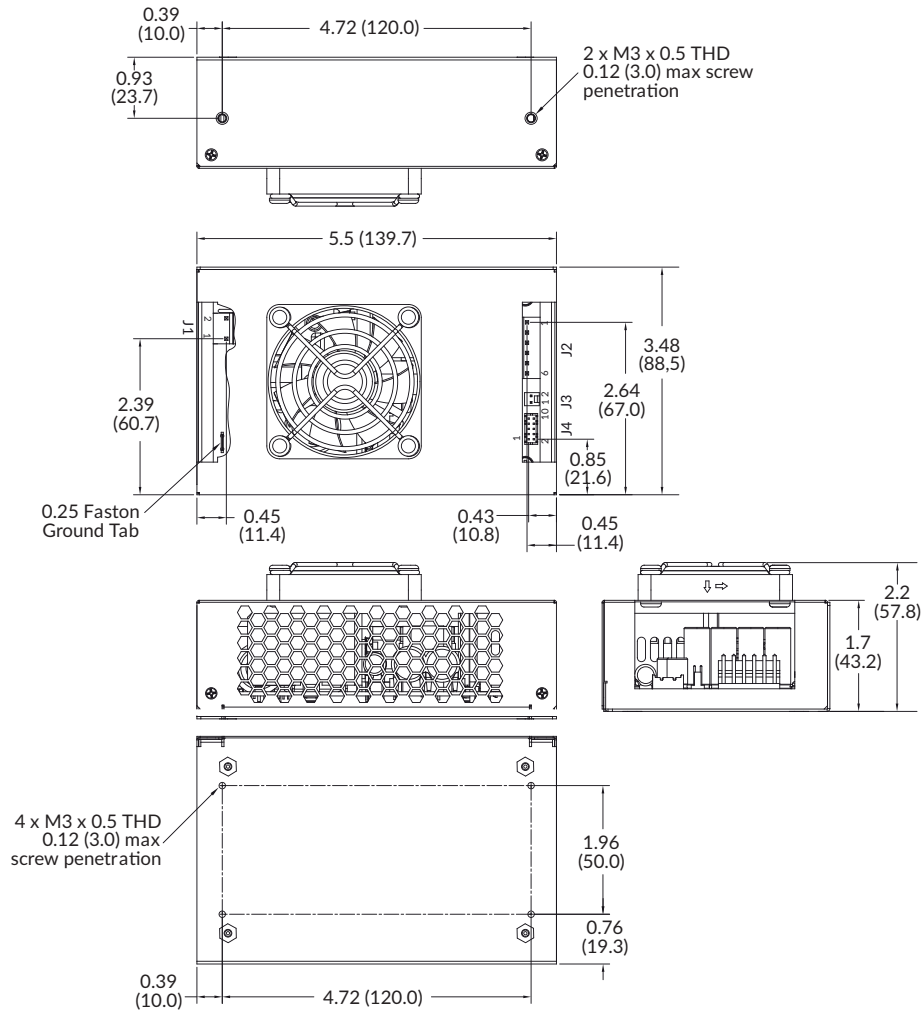

Input Connector J1 Molex pn. 09-65-2038	
Pin	Function
1	Line
2	Neutral

Output Connector J2 Molex pn. 09-65-2068	
Pin	Single Output
1	+V1
2	+V1
3	+V1
4	RTN
5	RTN
6	RTN

Fan Connector J3 Molex pn. 22-04-1021	
Pin	Function
1	Fan + (12V)
2	Fan -

Signal Connector J4 JST PN B10B-PHDSS			
Pin	Single	Pin	Single
1	+Sense	7	N/C
2	-Sense	8	N/C
3	XP Internal Use	9	N/C
4	Inhibit LO	10	N/C
5	Inhibit HI		
6	N/C		

Notes:

- All dimensions in inches (mm).
- Tolerance .xx = 0.02 (0.50); .xxx = 0.01 (0.25)
- J1 mates with Molex Housing Pn. 09-50-1031. J2 mates with Molex Housing Pn. 09-50-1061 and with Molex series 5194 crimp terminals. J4 mates with JST Housing

- PHDR-10VS and with JST SPHD-001T-P0.5 crimp terminals. J3 mates with Molex Housing Pn. 51191-0200 and with Molex series 50802 crimp terminals.
- In class II installations the cover is floating and provides 1 x MOPP (2 x MOOP).
- Weight: 1.15lbs (0.52kg)

GCS150 Series

Mechanical Details

End Fan Version (-EF suffix)

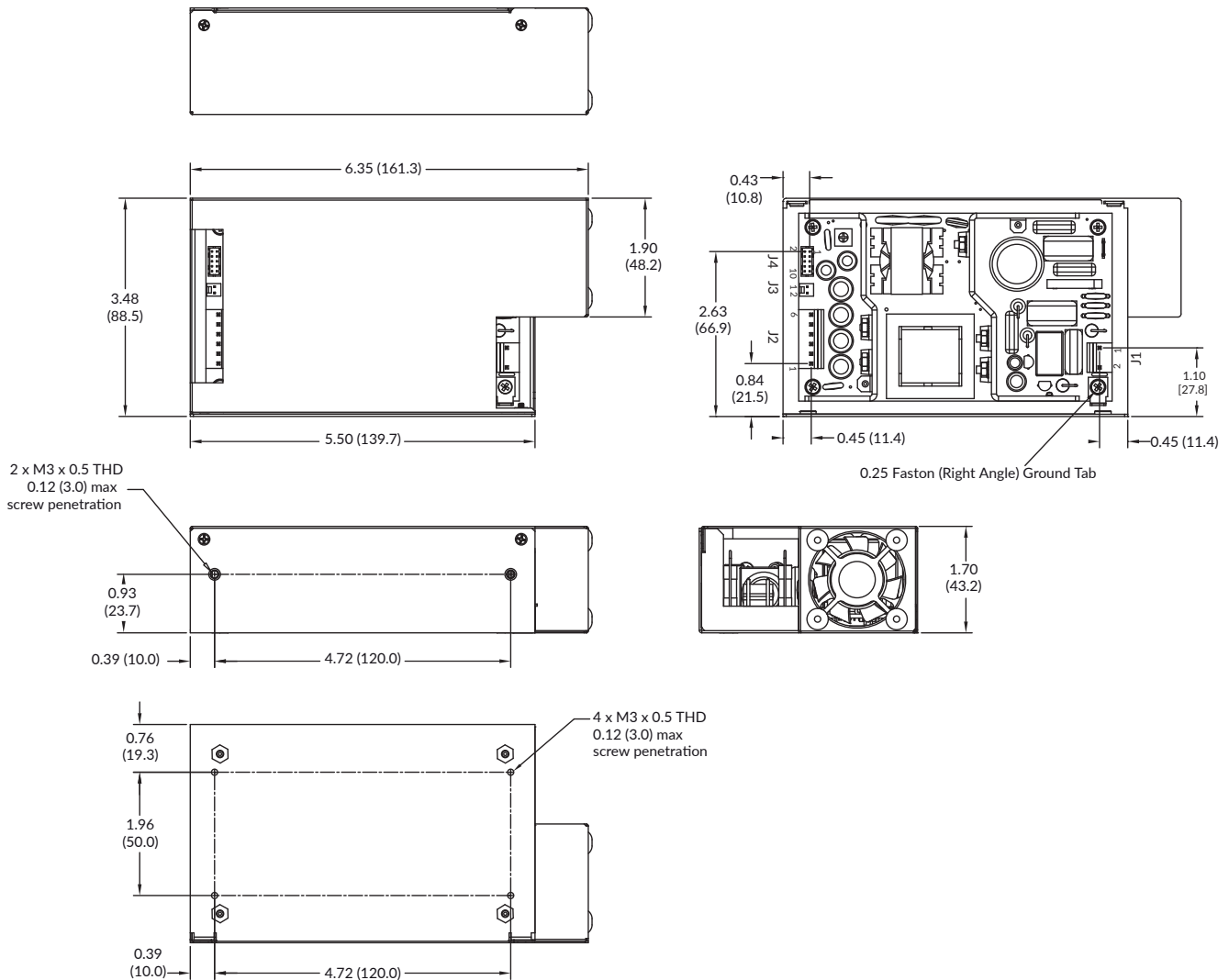

Input Connector J1 Molex pn. 09-65-2038	
Pin	Function
1	Line
2	Neutral

Output Connector J2 Molex pn. 09-65-2068	
Pin	Single Output
1	+V1
2	+V1
3	+V1
4	RTN
5	RTN
6	RTN

Fan Connector J3 Molex pn. 22-04-1021	
Pin	Function
1	Fan + (12V)
2	Fan -

Signal Connector J4 JST PN B10B-PHDSS			
Pin	Single	Pin	Single
1	+Sense	7	N/C
2	-Sense	8	N/C
3	XP Internal Use	9	N/C
4	Inhibit LO	10	N/C
5	Inhibit HI		
6	N/C		

Notes:

1. All dimensions in inches (mm).
2. Tolerance .xx = 0.02 (0.50); .xxx = 0.01 (0.25)
3. J1 mates with Molex Housing Pn. 09-50-1031. J2 mates with Molex Housing Pn. 09-50-1061 and both with Molex series 5194 crimp terminals. J4 mates with JST

- Housing Pn. PHDR-10VS and with JST SPHD-001T-P0.5 crimp terminals. J3 mates with Molex Housing Pn. 51191-0200 and with Molex series 50802 crimp terminals.
4. In class II installations the cover is floating and provides 1 x MOPP (2 x MOOP).
5. Weight: 1.30 lbs (0.59 kg)

Thermal Considerations

In order to ensure safe operation of the PSU in the end-use equipment, the temperature of the components listed in the table below must not be exceeded. Temperature should be monitored using K type thermocouples placed on the hottest part of the component (out of direct air flow). See below for component locations.

Component	Temperature Measurements	
	Max. Temperature °C	
T1 Coil	120°C	
L3 Coil	120°C	
Q1 Body	120°C	
Q3 Body	120°C	
C6	105°C	
C23	105°C	

Service Life

The estimated service life of the GCS Series is determined by the cooling arrangements and load conditions experienced in the end application. Due to the uncertain nature of the end application this estimated service life is based on the actual measured temperature of a key capacitors with in the product when installed by the end application. The worst case of the two figures should be taken as the indicative service life in 24/7 operation.

The graphs below expresses the estimated lifetime of a given component temperature and assumes continuous operation at this temperature.

Estimated Service Life vs Component Temperature

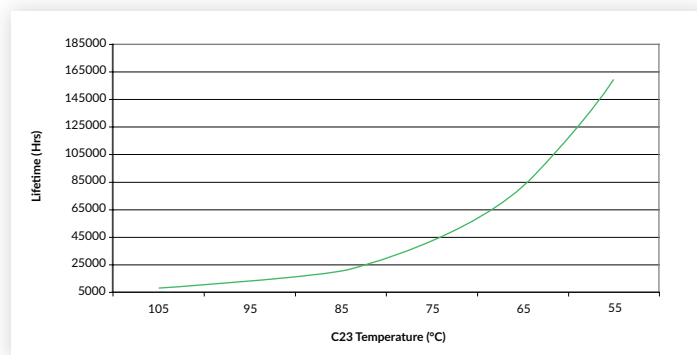
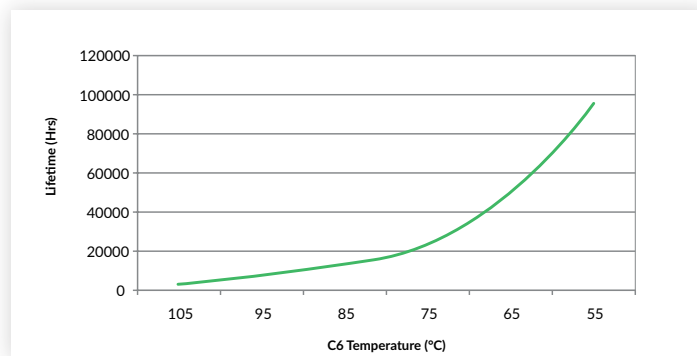

Specifications subject to change without notice.