

FLX1K3 1.3kW Fan cooled

AC-DC
power supplies

XP Power, a power solutions industry leader has revolutionized the configurable power supply market through their latest innovation, the FLXPro series. Housed in the most efficient, compact 1U form factor, the FLXPro series provides market leading levels of output power and power density – both at high line and low line conditions.

Uniquely designed from the ground up as a fully digital architecture, the FLXPro series incorporates XP Power's new "iPSU - Intelligent Power" technology that enables users to make fast, quality decisions based on FLXPro's rich set of diagnostics and data. Enhanced with XP Power's latest intuitive user interface, XPInsight the FLXPro series is not only a reliable configurable power supply, it is a trusted window into the health of your end application.

Delivering up to 1.3kW at high line conditions, the FLXPro series simplifies your unique installation requirements through a wide range of adjustable output module options that save time, complexity and cost.



Features

- ▶ Up to 23.2W/in³ power density
- ▶ Power from 1kW low line to 1.3kW high line
- ▶ Full power up to +50°C
- ▶ Efficiency up to 93%
- ▶ 2 x MOPP isolation for medical applications
- ▶ 4 selectable outputs from 9VDC to 66VDC
- ▶ Wide output adjustment range
- ▶ Fully digital architecture incorporating iPSU Intelligent Power technology
- ▶ Intuitive UI for configuration, monitoring and control
- ▶ Intelligent configurable fan speed
- ▶ Medical and ITE approvals
- ▶ 3 year warranty

Applications

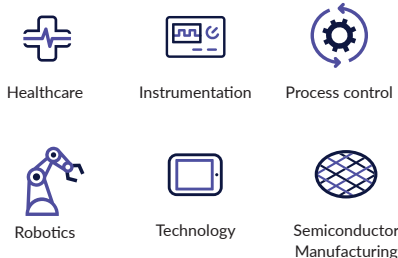

Dimensions

254.0 x 88.9 x 40.6mm (10.0 x 3.50 x 1.6")

Configuration Examples

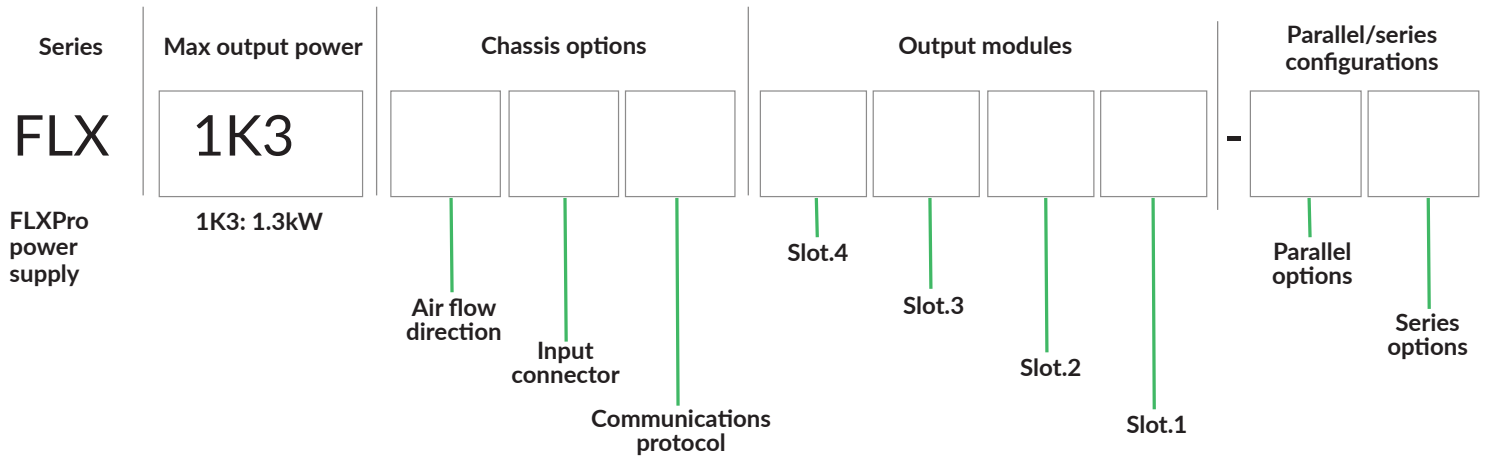

Air flow direction	Code
Normal (inlet to outlet)	N

Input power connector	Code
Barrier Terminal Block (AC Input)	A

Communication protocol	Code
PMBus® over I ² C	P

Output modules* - Maximum 4 letter codes (slot order mimics physical installation)					Code
V _{OUT} (nom.)	Adj. range	I _{OUT} (max.)	P _{OUT} (max.)	Slots used	
12V	±20%	21.7A	260W	1	A
15V	+10% to -40%	22.0A	330W	1	B
18V	±20%	13.5A	243W	1	C
24V	+10% to -40%	13.8A	330W	1	D
28V	±10%	6.9A	193W	1	E
30V	±10%	6.9A	206W	1	F
36V	±20%	6.9A	248W	1	G
48V	+10% to -40%	6.9A	330W	1	H
60V	+10% to -40%	5.5A	330W	1	J
Blank plate				1	0

*Working from left to right, slot 4 to 1, select any blank slots required. Next select the modules required based on their alphabetical code, placing them sequentially into the remaining slot positions alphabetically until all the slots in the part number configuration are filled. Consider modules in parallel or series that use more than 1 slot as individual modules for this step.

If the output voltage of an output module is adjusted to >60VDC then ES1 certification will be exceeded and the output must be treated as ES2.

Models & configurations

Parallel output options (single slot output modules of same type only)	Code
Modules 1 & 2 in parallel only	A
Modules 2 & 3 in parallel only	B
Modules 3 & 4 in parallel only	C
Modules 1 & 2 in parallel and modules 3 & 4 in parallel	F
Modules 1, 2 & 3 in parallel	N
Modules 2, 3 & 4 in parallel	P
Modules 1, 2, 3 & 4 in parallel	Q
No paralleling	Z

Series output options (single slot output modules of same type only)	Code
Modules 1 & 2 in series only	A
Modules 2 & 3 in series only	B
Modules 3 & 4 in series only	C
Modules 1 & 2 in series and modules 3 & 4 in series	F
Modules 1, 2 & 3 in series*	N
Modules 2, 3 & 4 in series*	P
Modules 1, 2, 3 & 4 in series*	Q
No series connections	Z

*Some configurations of series output options may exceed approved product safety limits and require additional customer safeguards to be put in place. Contact XP Power for more details.

Configuration examples

FLX1K3NAPBDHJ-ZZ 1.3kW, 4 slot chassis, normal air flow, barrier terminal block, PMBus
 Slot 4 = 15V 330W module (code 'B')
 Slot 3 = 24V 330W module (code 'D')
 Slot 2 = 48V 330W module (code 'H')
 Slot 1 = 60V 330W module (code 'J')
 No output paralleling, no outputs in series

FLX1K3NAPACJJ-AZ 1.3kW, 4 slot chassis, normal air flow, barrier terminal block, PMBus
 Slot 4 = 12V 260W module (code 'A')
 Slot 3 = 18V 243W module (code 'C')
 Slot 2 = 60V 330W module (code 'J')
 Slot 1 = 60V 330W module (code 'J')
 Modules 1 & 2 in parallel (60V 660W combined), no outputs in series

Input

Characteristic	Minimum	Typical	Maximum	Units	Notes & conditions
Input voltage	85		264	VAC	Minimum safety approved input voltage is 90VAC
Input frequency (AC)	47		63	Hz	
Power factor		0.99			At 115VAC & 230VAC full load
Input current			<10.5	A	115/230VAC
Inrush current			<40	A	At 264VAC, cold start at 25°C
Earth leakage current			<450	μA	
Input protection	12.5A/250V internal fuse in line and neutral				

Output

Characteristic	Minimum	Typical	Maximum	Units	Notes & conditions
Output voltage	9		66	VDC	See modules table
Voltage adjustment*	-40		+10	%	Adjustment range may vary, see modules table. ±10% via potentiometer
Voltage program*	60		110	%	Adjustment range may vary, see modules table. Via PMBus® only
Current program	0		105	%	Via PMBus® only
Set accuracy			±1	%	Nom. Voltage, $V_{STANDBY} \pm 3\%$
Hold up time	10	11		ms	
Line regulation			±0.1	%	Nom. Voltage, $V_{STANDBY} \pm 3\%$
Load regulation			±1	%	Nom. Voltage (0-100% & 100%-0 load)
Ripple & noise			1	%	V_{RATED} pk-pk or 100mV, which is larger
Minimum load	No minimum load required				
Transient response		3		%	Single slot, 50-100-50% load change
Overshoot protection	110		130	%	Latching, recycle input to restart
Overtemperature protection	Output shutdown with auto reset (110°C)				
Overload protection			110 ±3	%	Of full load, constant current mode
Short circuit protection	Constant current operation				
Temperature coefficient			0.02	%/°C	
Remote sense			0.5	V	Compensates for maximum voltage drop for 0.5VDC
Start up time			2	s	<3s for -20°C to 0°C
Overshoot			1	%	

*If the output voltage of an output module is adjusted to >60V then ES1 certification will be exceeded and the output must be treated as ES2.

Input derating

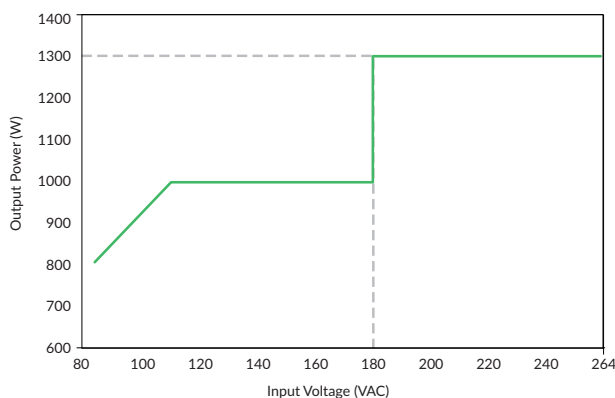

General

Characteristic	Minimum	Typical	Maximum	Units	Notes & conditions
Efficiency		>93		%	At 230VAC
		>89			At 115VAC
Isolation: Input to output	4000			VAC	
Input to ground	2500			VDC	
Output to ground	500			VDC	
Power density		1.416 (23.2)		W/cm ³ (W/in ³)	At high line
Mean time between failures	500			khrs	Telecordia SR-332 Issue 4, +25°C
Weight		1.58 (3.5)		kg (lbs)	

Environmental

Characteristic	Minimum	Typical	Maximum	Units	Notes & conditions
Operating temperature	-20		+70	°C	Derate rated power linearly 2.5%/°C +50°C to +70°C
Storage temperature	-40		+85	°C	
Humidity (operating/storage)	5		95	%RH	Non-condensing
Operating altitude			5000	m	ITE
			4000		Medical
Transport altitude			10000	m	
Cooling	Fan cooled with intelligent fan speed control				
Shock	±3 x 30g shocks in each plane, total 18 shocks. 30g = 11ms (±0.5ms) half sine. Conforms to EN60068-2-27 & EN60068-2-47				
Vibration	Single axis 10-500Hz at 2g sweep and endurance at resonance in all 3 planes. Conforms to EN60068-2-6				

Thermal derating curve

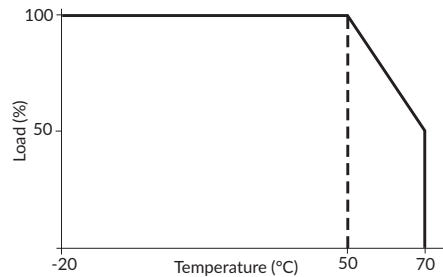

Safety approvals

Certification	Standard	Notes & conditions
CB	IEC62368-1 Ed 4	Information technology
	IEC60601-1 Ed 3	Medical
UL	UL62368-1 Ed 3, CSA62368-1 Ed 3	Information technology
	ANSI/AAMI ES60601-1	Medical
CE	Meets all applicable directives	
UKCA	Meets all applicable legislation	
Equipment protection class	Class I	

Means of protection		
Input to output	2 x MOPP (Means of Patient Protection)	IEC60601-1 Ed 3
Input to ground	1 x MOPP	

Emissions - EMC

Phenomenon	Standard	Test level	Notes & conditions
Conducted	EN55011/EN55032	Class B	
Radiated	EN55011/EN55032	Class B	
Harmonic current	EN61000-3-2	Class A	

Emissions - immunity

Phenomenon	Standard	Test Level	Criteria	Notes & conditions
ESD	IEC61000-4-2	4	A	±8kV contact, ±15kV Air
Radiated	IEC61000-4-3	3	A	
	IEC60601-1-2	N/A	A	10V/m
EFT	IEC61000-4-4	3	A	
Surge	IEC61000-4-5	3	A	
Conducted	EN61000-4-6	3	A	
Magnetic fields	EN61000-4-8	4	A	
Dips and interruptions	IEC61000-4-11 100VAC	Dip 100%, 8.4ms	A	
		Dip 100%, 16.7ms	B	
		Dip 60%, 200ms	B	
		Dip 30%, 500ms	A	
		Dip 20%, 5000ms	B	
		Int 100%, 5000ms	B	
	IEC61000-4-11 240VAC	Dip 100%, 10ms	A	
		Dip 100%, 20ms	B	
		Dip 60%, 100ms	B	
		Dip 30%, 500ms	A	
		Dip 20%, 5000ms	A	
		Int 100%, 5000ms	B	
	EN60601-1-2 100VAC	Dip 100%, 10ms	A	
		Dip 100%, 20ms	B	
		Dip 60%, 100ms	B	
		Dip 30%, 500ms	A	
		Int 100%, 5000ms	B	
	EN60601-1-2 240VAC	Dip 100%, 10ms	A	
		Dip 100%, 20ms	B	
		Dip 60%, 100ms	A	
Dip 30%, 500ms		A		
Semi F47 - 0706	At input voltages >200VAC		A	

Signals, controls & connections

Signal connections

Function	Description
PMBus®	<p>Operation of the product using the distributed control interfaces and associated protocols, is defined in the supporting document 'FLXPro Communication, Control and Status Specification'. Installation and use of the XPInsight graphical user interface, is defined in the supporting document 'XPInsight User Manual'. These documents are available through the XP Power website. Digital control provides the opportunity to create application specific behaviors for many parameters including output voltage and current, alarm levels etc. These can be permanently saved to the power supply and/or to a file for batch configuration.</p> <p>Real-time control, monitoring and datalogging provides the opportunity to integrate the product into a digital control loop, create power profiles and monitor the product status.</p> <p>Analog to digital accuracy: V_{OUT} monitoring accuracy: $\pm 0.1\%$ of V_{NOM}. I_{OUT} monitor accuracy: $\pm 0.1\%$ of full load current V_{OUT} & I_{OUT} setting accuracy: $\pm 0.1\%$ of V_{NOM} / rated current.</p>
AC OK	Uncommitted opto-transistor. Circuit conducting means AC input is within range. User configurable. Minimum 2ms warning before output shutdown. See typical connection diagram on page 9.
DC OK (input stage)	Uncommitted opto-transistor. Logic is user configurable. See typical connection diagram on page 9.
DC OK (output modules)	Uncommitted opto-transistor. Logic is user configurable. See typical connection diagram on page 9.
Remote inhibit	Uncommitted opto-diode. Supplied as Active = High such that remotely supplying a 5V signal to this connector pin will inhibit the operation of the FLXPro unit – either the input stage or an individual output module
Fan fail/temp warning	Provides 10s warning of Fan Fail or Over temperature conditions. 3.3V TTL compatible signal, referenced to Iso Gnd/SGND. High = Fan fail or Over-temp. Low = Fan and temperature OK. Auto-recovery.
Chassis sync	Synchronize the output start-up of FLXPro units, following application of AC input. Link the Sync pins and the relevant Iso Gnd or SGND pins between the units.
Current share	Balance output current between up to 4 output modules, connected in parallel, by linking the current share pins between modules

Communications/signals connector

Pin	Function	Description
1	5V_SB_RTN	5VDC/2A standby return
2	5V_SB_RTN	5VDC/2A standby return
3	5V SB	5VDC/2A standby
4	5V SB	5VDC/2A standby
5	Not used	
6	Not used	
7	CHASSIS SYNC	Synchronizes the output start up of multiple FLXPro units following application of AC input
8	FAN_FAIL	Open drain, referenced to SGND, Low = Fan OK, High = Fan failed
9	I ² C_SCL	I ² C data line, 10k Ω internal pull up to 3.3VDC
10	I ² C_SDA	I ² C clock line, 10k Ω internal pull up to 3.3VDC
11	COM	Signal ground, common with the DC power output 0VDC terminal
12	I ² C_A2	I ² C device address bit, 10k Ω internal pull up to 3.3VDC
13	I ² C_A1	I ² C device address bit, 10k Ω internal pull up to 3.3VDC
14	I ² C_A0	I ² C device address bit, 10k Ω internal pull up to 3.3VDC
15	ACOK_E	Emitter, uncommitted opto-isolator, circuit conducting = AC within range
16	ACOK_C	Conductor, uncommitted opto-isolator, circuit conducting = AC within range
17	REM_INH_CAT	Cathode, uncommitted opto-diode, supplied as active = inhibit, configurable
18	REM_INH_AN	Anode, uncommitted opto-diode, supplied as active = inhibit, configurable
19	DCOK_E	Emitter, uncommitted opto-diode, circuit conducting = V_{OUT} within range
20	DCOK_C	Conductor, uncommitted opto-diode, circuit conducting = V_{OUT} within range

Signals, controls & connections

Output module connector

Module view

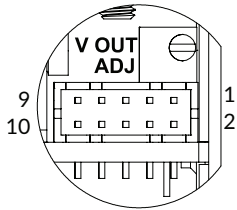

Pin	Function	Description
1	RS+	Positive remote sense
2	RS-	Negative remote sense
3	I_SHARE ⁽¹⁾	0 to 2.6VDC for current sharing of units in parallel
4	I_SHARE ⁽¹⁾	0 to 2.6VDC for current sharing of units in parallel
5	SYNC	Synchronizing of up to 4 same-voltage output modules connected in parallel. Do not use with modules connected in series
6	COM	Signal ground
7	REM_INH_AN	Anode. Uncommitted opto-diode. Supplied as Active = Inhibit. Configurable
8	REM_INH_CAT	Cathode. Uncommitted opto-diode. Supplied as Active = Inhibit. Configurable
9	DCOK_C	Conductor. Uncommitted opto-isolator. Circuit conducting = V _{OUT} within range
10	DCOK_E	Emitter. Uncommitted opto-isolator. Circuit conducting = V _{OUT} within range

Notes:

- Linking the current share pins between identical output models connected in parallel, will force the current to be shared. Maximum of 4 modules in parallel. Sharing accuracy ±3% of a single unit current rating.

LED Signals

Status	AC LED color state	DC LED color state	Description
AC IN LOW	FLASH ✖	SOLID R	AC input is below control system startup voltage
AC OK DC OK	SOLID G	SOLID G	AC input OK, DC output OK
AC OK DC OFF	SOLID G	FLASH ✖	AC input is OK, DC output is off / disabled
INT. FAULT	SOLID B	CYCLE G → B → R	General internal fault – contact XP Power
OVP DC-DC	SOLID B	CYCLE G ↔ R	Module DC output over voltage protection
OCP DC-DC	SOLID B	CYCLE G ↔ B	Module DC output over current protection
OVER TEMP	FLASH ✖	CYCLE B ↔ R	Over temperature conditions. Auto recovery
FAN FAIL	FLASH ✖	CYCLE G → B → R	Fan failure – contact XP Power
INT. COMM FAIL	FLASH ✖	CYCLE G ↔ B	Internal digital comms failure – contact XP Power
MODULE FAIL	FLASH ✖	CYCLE G ↔ R	Module failure – contact XP Power
PFC FAIL	FLASH ✖	CYCLE B ↔ R	Input stage PFC failure – contact XP Power

Signals, controls & connections

Analog signals

Input stage AC OK/power fail

Global AC OK is an isolated transistor of an optocoupler providing a minimum of 5ms warning of loss of output regulation. The signal is fully isolated and the collector and emitter must be connected externally. Maximum sink current 2mA, maximum voltage 60VDC.

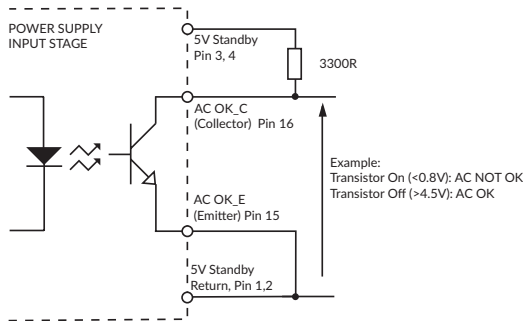

Input stage DC OK

Input stage DC OK is an isolated transistor of an optocoupler providing a warning that the output voltage has fallen below 90% of nominal. The signal is fully isolated and the collector and emitter must be connected externally. Maximum sink current 2mA, maximum voltage 60VDC.

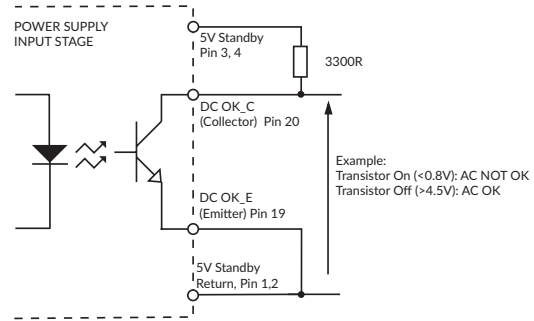

Input stage/global remote inhibit

Input stage/global remote inhibit is a configurable control signal input which turns the power supply on or off by supplying 2mA to 5mA into the pin.

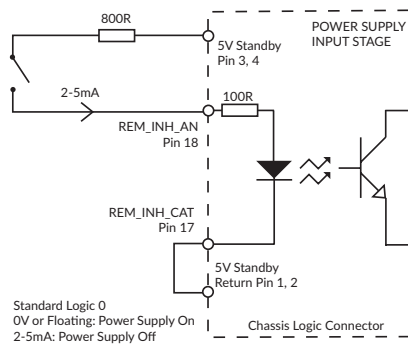

Module remote inhibit

Module remote inhibit is a configurable control signal input which turns the output module on or off by supplying 2mA to 5mA into the pin.

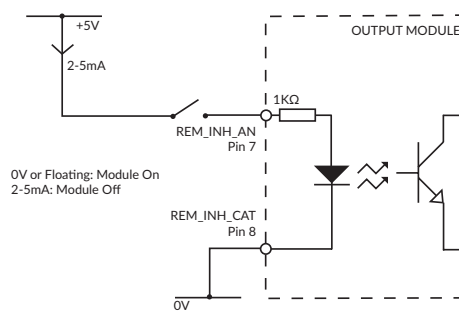

Module DC OK

Module DC OK is a nominal 'ON' isolated transistor of an optocoupler which provides a warning of the loss of output regulation on the main output of the module. Maximum sink current 2mA, maximum voltage 60VDC.

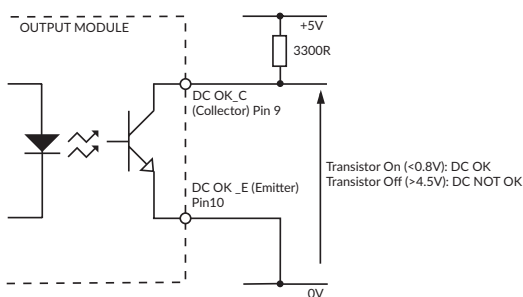

Fan Fail/temperature warning

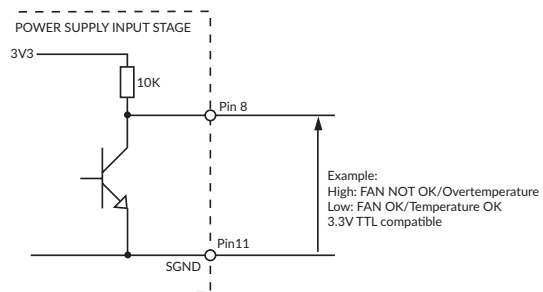

Analog signals continued on page 10

Signals, controls & connections

Analog signals (continued)

Module current share

Connecting pins 3 or 4 of like voltage modules (4 maximum) within the same chassis will force the current to share between the outputs.

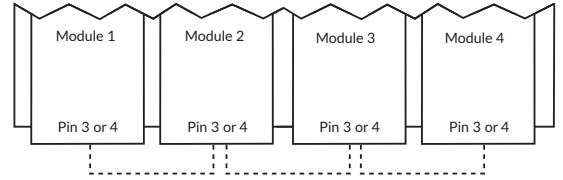

Mechanical details

FLX1K3 chassis

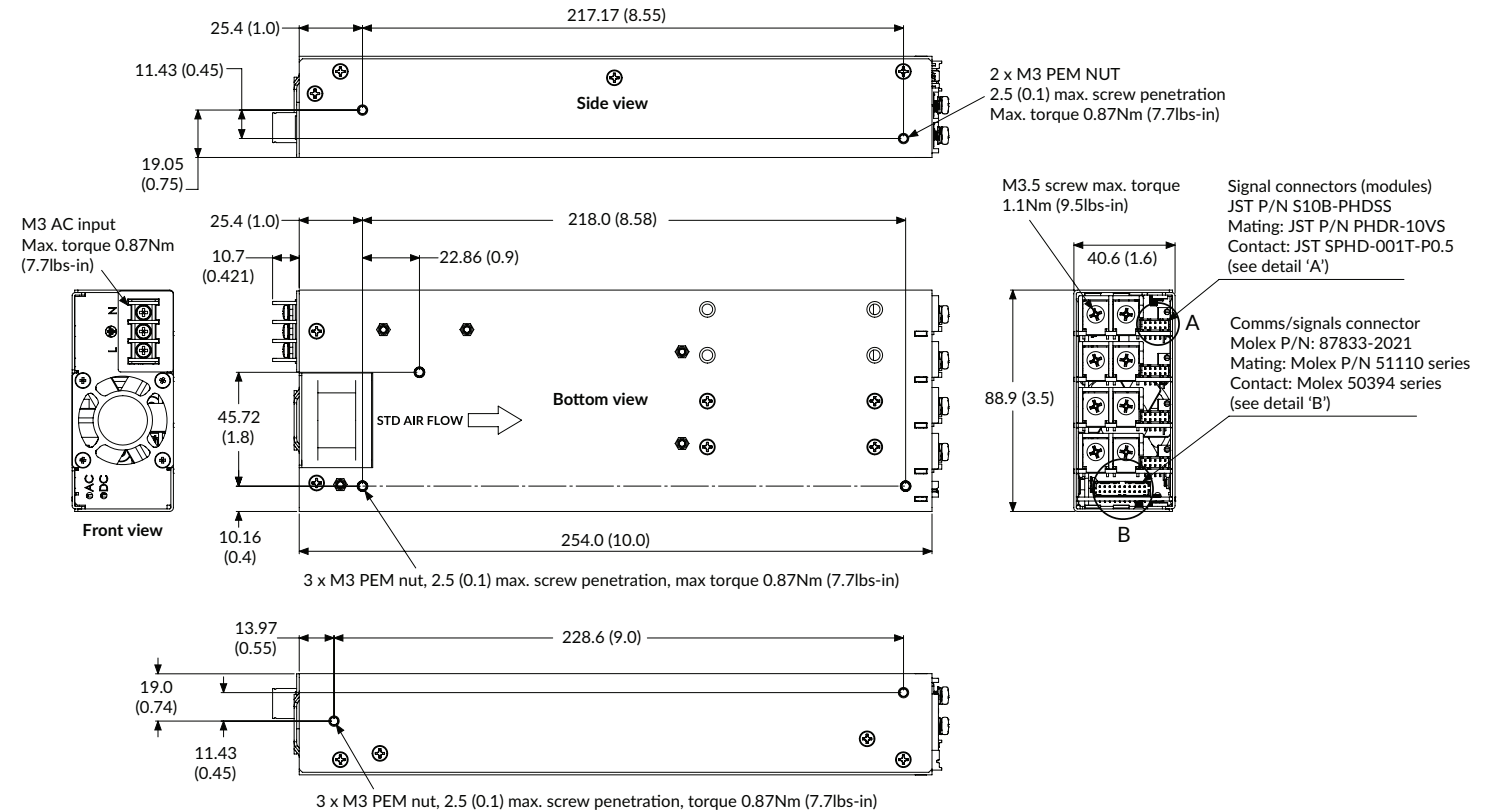

Detail A

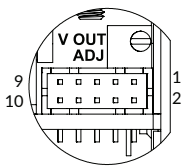

Output module connector 10 pin	
Pin	Function
1	RS+
2	RS-
3	I_SHARE
4	I_SHARE
5	SYNC
6	COMM
7	REM_INH_AN
8	REM_INH_CAT
9	DCOK_C
10	DCOK_E

Detail B

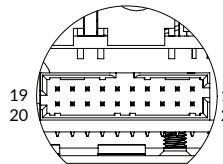

Comms/signals connector 20 pin			
Pin	Function	Pin	Function
1	5V_SB_RTN	11	COM
2	5V_SB_RTN	12	I²C_A2
3	5V_SB	13	I²C_A1
4	5V_SB	14	I²C_A0
5	N/A	15	ACOK_RTN
6	N/A	16	ACOK_C
7	CHASSIS SYNC	17	REM_INH_RTN
8	FAN_FAIL	18	REM_INH
9	I²C_SCL	19	DCOK_RTN
10	I²C_SDA	20	DCOK_C

Notes:

1. All dimensions in mm (inches).
 Tolerance x.xx = ±0.50 (0.02), x.xxx = ±0.25 (0.01)

2. Weight: 1.58kg (3.5lbs) approx.

Specification subject to change without notice