

XTL15 fleXPower Series

1.5kW FAN COOLED

AC-DC POWER SUPPLIES

The 3 phase XTL15 fleXPower series is a modular power supply which can be configured into a bespoke solution for quick delivery of samples, prototypes and low volume production with up to 1500 Watts of output power. Configurations may comprise up to 7 modules chosen from 44 single output modules and 16 dual output modules ranging from 3.3V at 66W to 60V at 750W. Modules may be combined in series or parallel to create a single output at the chassis power rating. Modules of unlike power can be paralleled and will current share within 10%. Opto-isolation of control and monitoring signals provides further configuration flexibility, including a global Inhibit/Enable function. A continuous 5V/2A housekeeping output is present when the AC supply is active.

XTL15 fleXPower consists of a chassis in which there are 14 slots, allowing for up to 7 individual modules. All models have EN62368-1 and UL62368 approvals. A single phase input version is available, see fleXPower datasheet for details.



Features

- Configurable for fast time to market
- Flexible series and parallel capability
- EN62368-1 and UL62368 safety approvals
- 3 phase input 180 to 264VAC
- 1-14 outputs
- Variable speed fan (optional)
- Fully featured signals and controls
- SEMI F47 compliant
- -20°C to +70°C operating temperature
- 3 year warranty

Summary

Characteristic	Minimum	Typical	Maximum	Units	Notes & Conditions
Output Power Rating			1500	W	
Power Factor	0.93			Hz	
Efficiency		88		%	
Operating Temperature	-20		+70	°C	
Output Ripple & Noise		1		%	
Hold Up Time	20			ms	
Housekeeping/Standby Supply		5V/2A			

Notes:

For mechanical details, refer to page 7.

Applications

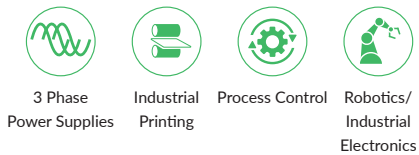

Dimensions

279.4 x 177.8 x 63.5 mm (11.00" x 7.00" x 2.50")

XTL15 fleXPower Series



Configuration Examples

The XTL15 range allows for simple configuration of a custom modular power supply with up to seven outputs. The chassis consists of fourteen slots, and modules are either two, three or four slots wide.

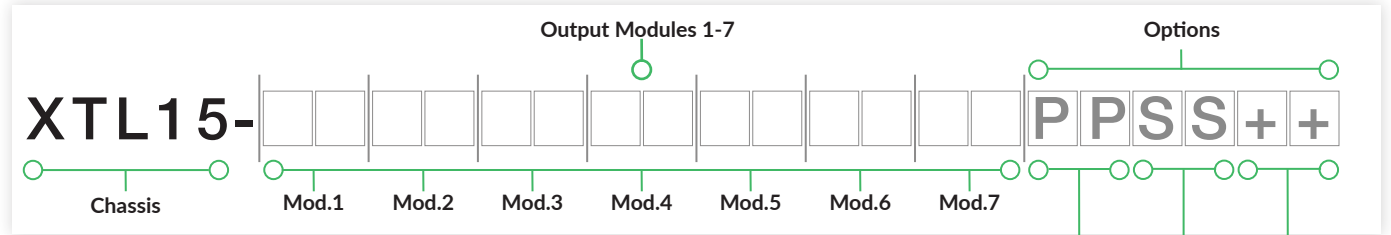

Step 1

XTL15 can accommodate up to seven modules, resulting in an extensive range of output combinations. However, as all modules are designed to fit across either 2, 3 or 4 slots in the chassis, configuration is very simple. Select the appropriate modules for your output requirements, ensuring that all modules will fit in the chassis. First, insert 7 or 4 series modules, ordered lowest voltage to highest. Next in order, insert 3 series modules, ordered lowest voltage to highest. Follow with 2 series, then 5 series dual output, ordered alphabetically A-Z. Then 1 series, ordered lowest voltage to highest.

Step 2

Add any required options. These are grouped into three types; parallel options, series options and other options. The standard signal set for each chassis includes Global Inhibit, Global DC OK and Global AC OK, each having logic 0 operation. Optionally a logic 1 operating version of each is available along with reverse air flow.

Dual Output - Module Voltage/Current Rating					
Output 1		Output 2		Slots	Code
Voltage	Current	Voltage	Current		
5.0V	10.0A	5.0V	10.0A	2	5A
5.0V	10.0A	3.3V	10.0A	2	5B
12.0V	10.0A	12.0V	8.0A	2	5D
15.0V	8.0A	15.0V	6.0A	2	5E
15.0V	8.0A	15.0V	6.0A	2	6E*
15.0V	8.0A	12.0V	8.0A	2	5F
12.0V	10.0A	5.0V	10.0A	2	5G
12.0V	10.0A	3.3V	10.0A	2	5H
12.0V	10.0A	2.0V	10.0A	2	5J
15.0V	10.0A	5.0V	10.0A	2	5K
15.0V	10.0A	3.3V	10.0A	2	5L
15.0V	10.0A	2.0V	10.0A	2	5M
24.0V	6.0A	5.0V	10.0A	2	5N
24.0V	6.0A	5.0V	10.0A	2	6N*
24.0V	6.0A	3.3V	10.0A	2	5P
24.0V	6.0A	2.0V	10.0A	2	5Q

Total power for dual output module must not exceed 175W max. 5 series modules require 10% load on output 1 to meet specified regulation on output 2.

*No minimum load needed on output 1 for regulation.

Example

XTL15-3C3L2C-000001

(Leave gray numbers blank if no options are required)

XTL15 - 1500W industrial 3ø chassis, 14 module slots available.

3C - 3.3V @ 60.0A. Three slot width module.

3L - 15.0V @ 20.0A. Three slot width module.

2C - 3.3V @ 40.0A. Two slot width module.

00 - No parallel option.

00 - No series option.

01 - Reverse air.

Single Output - Module Voltage/Current Rating						
Voltage	Current	Ipk	Power	Ppk	Slots	Code
3.3V	20.0A	n/a	66W	n/a	2	1C
3.3V	40.0A	n/a	132W	n/a	2	2C
3.3V	60.0A	n/a	198W	n/a	3	3C
5.0V	20.0A	n/a	100W	n/a	2	1D
5.0V	40.0A	n/a	200W	n/a	2	2D
5.0V	60.0A	n/a	300W	n/a	3	3D
8.0V	25.0A	n/a	200W	n/a	2	2H
10.0V	20.0A	n/a	200W	n/a	2	2I
10.0V	30.0A	n/a	300W	n/a	3	3I
12.0V	8.50A	n/a	102W	n/a	2	1J
12.0V	17.0A	n/a	204W	n/a	2	2J
12.0V	25.0A	n/a	300W	n/a	3	3J
12.0V	62.5A	n/a	750W	n/a	4	7J
12.0V	62.5A	n/a	750W	n/a	4	4J ⁽²⁾
15.0V	7.00A	n/a	105W	n/a	2	1L
15.0V	14.0A	n/a	210W	n/a	2	2L
15.0V	20.0A	n/a	300W	n/a	3	3L
15.0V	50.0A	n/a	750W	n/a	4	7L
15.0V	50.0A	n/a	750W	n/a	4	4L ⁽²⁾
18.0V	16.7A	n/a	300W	n/a	3	3N
24.0V	5.00A	n/a	120W	n/a	2	1P
24.0V	10.5A	n/a	252W	n/a	2	2P
24.0V	17.0A	n/a	408W	n/a	3	3P
24.0V	31.5A	n/a	750W	n/a	4	7P
24.0V	31.5A	n/a	750W	n/a	4	4P ⁽²⁾
24.0V	5.00A	10.0A	120W	240W	2	1R ⁽¹⁾
24.0V	10.5A	21.0A	252W	504W	2	2R ⁽¹⁾
24.0V	17.0A	34.0A	408W	816W	3	3R ⁽¹⁾
28.0V	4.50A	n/a	126W	n/a	2	1Q
28.0V	9.00A	n/a	252W	n/a	2	2Q
28.0V	14.0A	n/a	392W	n/a	3	3Q
28.0V	26.8A	n/a	750W	n/a	4	7Q
28.0V	26.8A	n/a	750W	n/a	4	4Q ⁽²⁾
30.0V	8.4A	n/a	252W	n/a	2	2S
30.0V	13.5A	n/a	405W	n/a	3	3S
36.0V	3.50A	n/a	126W	n/a	2	1U
36.0V	7.00A	n/a	252W	n/a	2	2U
36.0V	11.0A	n/a	396W	n/a	3	3U
36.0V	21.0A	n/a	750W	n/a	4	7U
36.0V	21.0A	n/a	750W	n/a	4	4U ⁽²⁾
42.0V	9.05A	n/a	400W	n/a	3	3V
48.0V	2.50A	n/a	120W	n/a	2	1W
48.0V	5.20A	n/a	249W	n/a	2	2W
48.0V	8.50A	n/a	408W	n/a	3	3W
48.0V	15.7A	n/a	750W	n/a	4	7W
48.0V	15.7A	n/a	750W	n/a	4	4W ⁽²⁾
60.0V	2.00A	n/a	120W	n/a	2	1Y
60.0V	4.20A	n/a	252W	n/a	2	2Y
60.0V	7.00A	n/a	420W	n/a	3	3Y
60.0V	12.5A	n/a	750W	n/a	4	7Y
60.0V	12.5A	n/a	750W	n/a	4	4Y ⁽²⁾

1. Peak power available for 10 seconds with 35% duty cycle, if peak power rating is exceeded output may latch, recycle input to reset.
2. '4' series modules not recommended for new designs.

Parallel Option Codes	
Code	Description
00	No parallel required
12	Modules 1 & 2
13	Modules 1 to 3
14	Modules 1 to 4
23	Modules 2 & 3
24	Modules 2 to 4
25	Modules 2 to 5
34	Modules 3 & 4
35	Modules 3 to 5
40	Modules 1 & 2, 3 & 4

Series Option Codes	
Code	Description
00	No series required
12	Modules 1 & 2
13	Modules 1 to 3
23	Modules 2 & 3
24	Modules 2 to 4
40	Modules 1 & 2, 3 & 4

Other Option Codes	
Code	Description
01	Reverse Air
02	Global Enable - Logic 1
03	Option 01 & 02
04	Global DC OK - Logic 1
05	Option 01 & 04
06	Option 02 & 04
07	Option 01, 02 & 04
08	Global AC OK - Logic 1
09	Option 01 & 08
10	Option 02 & 08
11	Option 01, 02 & 08
12	Option 04 & 08
13	Option 01, 04 & 08
14	Option 02, 04 & 08
15	Option 01, 02, 04 & 08
16	Fan Speed Control
17	Option 01 & 16
18	Option 02 & 16
19	Option 04 & 16
20	Option 08 & 16
21	Option 01, 02 & 16
22	Option 01, 04 & 16
23	Option 01, 08 & 16
24	Option 02, 04 & 16
25	Option 02, 08 & 16
26	Option 04, 08 & 16
27	Option 01, 02, 04 & 16
28	Option 01, 02, 08 & 16
29	Option 02, 04, 08 & 16
30	Option 01, 02, 04, 08 & 16

1. Fancard options 16-30 will occupy 2 slots. See mechanical drawing, page 9.

XTL15 fleXPower Series



Input

Characteristic	Minimum	Typical	Maximum	Units	Notes & Conditions
Input Voltage - Operating	180		264	VAC	4 wire 3 phase (no neutral), 300VAC, 5s
Input Frequency	47		63	Hz	
Power Factor	0.93				
Input Current - per phase		6		A	180VAC
		4			264VAC
Inrush Current			60	A	Cold start 25°C at 264VAC
Earth Leakage Current			1	mA	at 264VAC, 60Hz/<3.5mA single fault
Input Protection	F15A/250V internal fuse in each line				

Output

Characteristic	Minimum	Typical	Maximum	Units	Notes & Conditions
Output Voltage	3.3		60	VDC	See Modules table
Output Voltage Adjustment	10			%	See Modules table
Minimum Load	No minimum load required for 2 slot, 3 slot or 4 slot single output or 6x dual output modules. 5x dual outputs require 10% load on V1 to meet specified regulation on V2				
Start Up Delay		1.5	2.0	s	
Hold Up Time	20			ms	With full output load
Line Regulation			<0.1	%	
Load Regulation			<1	%	
Ripple & Noise			50/1	mV/% pk-pk	At 20MHz bandwidth whichever is the greater. 6E module has 1.5% max on V1 and V2. 6N modules has 1.5% max on V1 and 3% max on V2
Overvoltage Protection	115		130	% V nom	
Overtemperature Protection			115	°C	
Overload Protection	110		140	% I nom	
Short Circuit Protection	Continuous trip and restart (hiccup mode)				
Temperature Coefficient			0.03	%/°C	
Remote Sense			0.5	V	Compensates for maximum voltage drop of 0.5V
Enable & Inhibit					See signals page
Current Share					See signals page
Housekeeping Voltage		5V/2A			Isolation classed as Functional, between this and all other circuits

XTL15 fleXPower Series



General

Characteristic	Minimum	Typical	Maximum	Units	Notes & Conditions
Efficiency		88		%	Configuration dependent
Isolation: Input to Output	3000			VAC	2 x MOPP
Input to Ground	1500			VAC	1 x MOPP
Output to Ground	250			VDC	
Switching Frequency		65		kHz	PFC converter
		200			For modules
Mean Time Between Failure		225		khrs	MIL-STD-217F at 25°C GB

Environmental

Characteristic	Minimum	Typical	Maximum	Units	Notes & Conditions
Operating Temperature	-20		+70	°C	For operation above +50°C, derate linearly to 50% load at +70°C
Storage Temperature	-40		+85	°C	
Humidity	5		95	%RH	Non-condensing
Operating Altitude			3000	m	
Cooling	Forced air cooling (via field-replaceable internal fan). Fan speed control optional				
Shock	MIL STD-810 Method 516.4 Procedure 1, 30g, half sine, 6 axes				
Vibration	MIL STD-810 Method 514.4 Procedure 1, 1g rms, 5-500Hz, 3 axes				

EMC: Emissions

Phenomenon	Standard	Test Level	Notes & Conditions
Conducted	EN55032	Class A	
Radiated	EN55032	Class A	
Harmonic Fluctuations	EN61000-3-3	Class A	

XTL15 fleXPower Series



EMC: Immunity

Phenomenon	Standard	Test Level	Criteria	Notes & Conditions
Low Voltage PSU EMC	EN61204-3	High severity level	As below	
ESD	EN61000-4-2	4	A	
Radiated	EN61000-4-3	10V/m	A	
EFT	EN61000-4-4	3	A	
Surge	EN61000-4-5	Installation class 3	A	
Conducted	EN61000-4-6	10V/m	A	
Magnetic Fields	EN61000-4-8	3A/m	A	
Dips and Interruptions	EN55024 (180VAC)	Int >100% (0VAC) 8.4ms	A	
		Int 100% (0VAC) 16.7ms	A	
		Dip 60% (72VAC) 200ms	A	
		Dip 30% (126VAC) 500ms	A	
		Dip 20% (144VAC) 5000ms	A	
	EN55024 (208VAC)	Int >100% (0 VAC) 10ms	A	
		Int 100% (0 VAC) 20ms	A	
		Dip 60% (83VAC) 200ms	A	
		Dip 30% (145VAC) 500ms	A	
		Dip 20% (166VAC) 5000ms	A	
	SEMI F47-0706	208VAC nominal	A	

Safety Approvals

Certification	Standard	Notes & Conditions
CB	IEC60950-1 / IEC62368-1	Information Technology
UL	UL62368-1	Information Technology
EN	EN62368-1	Information Technology
CE	Meets all applicable directives	
UKCA	Meets all applicable legislation	
Equipment Protection Class	Class I	

XTL15 fleXPower Series

Signals

Global AC OK/Power Fail

Global AC OK is an isolated transistor of an optocoupler providing a minimum of 5ms warning of loss of output regulation. The signal is fully isolated and the collector and emitter must be connected externally.

Maximum sink current 2mA, maximum voltage 20V.

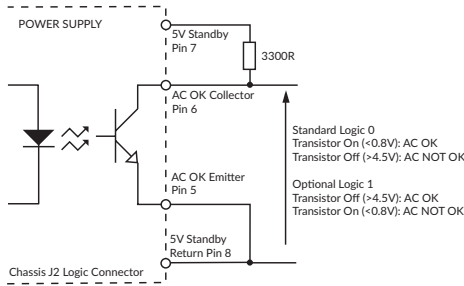

Global Inhibit

Global Inhibit is an isolated control signal input which turns the power supply off by supplying 2 to 5mA into the pin. Global Enable option available, see 'Other Option Codes' table.

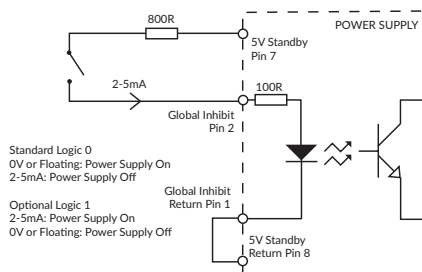

Module DC OK

Module DC OK is a nominal "ON" isolated transistor of an optocoupler which provides a warning of the loss of output regulation on the main output of the module.

Maximum sink current 2mA, maximum voltage 20V.

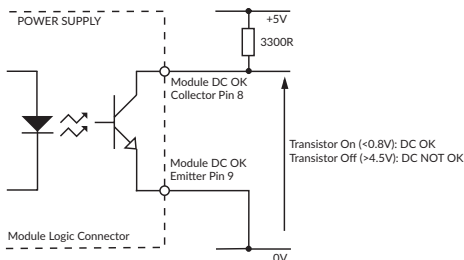

Current Share

Connecting pins 2 and 4 of like voltage modules (4 maximum) within the same chassis or separate chassis will force the current to share between the outputs. Different slot width modules share in proportion to their output current rating.

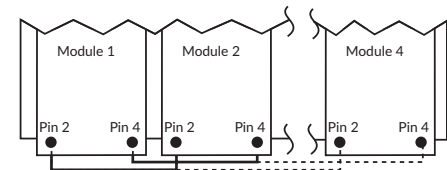

Global DC OK

Global DC OK is an isolated transistor of an optocoupler providing warning that the output voltage has fallen below 90% of nominal. The signal is fully isolated and the collector and emitter must be connected externally.

Maximum sink current 2mA, maximum voltage 20V.

On Dual output module, DC OK monitors V1 output only.

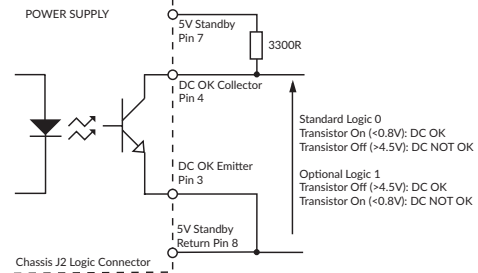

Fan Fail

When fan speed control fitted (option 16).

Open connector signal warns of any fan failure.

Note: Can use 5V standby for 5V EXT.

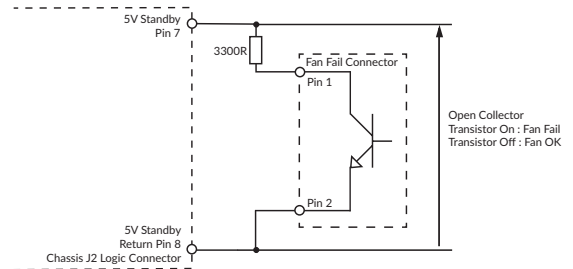

Module Inhibit

Module Inhibit signal is an isolated control signal which turns the module off by supplying 2 to 5mA into the pin. '4' series modules have a 100R internal series resistor. Add resistance as necessary to maintain drive current at 2-5mA.

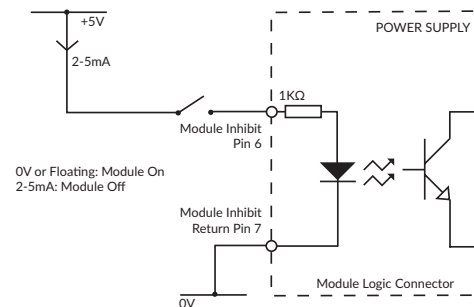

XTL15 fleXPower Series



Module Mechanical Details

Single Output

2 Slot Modules

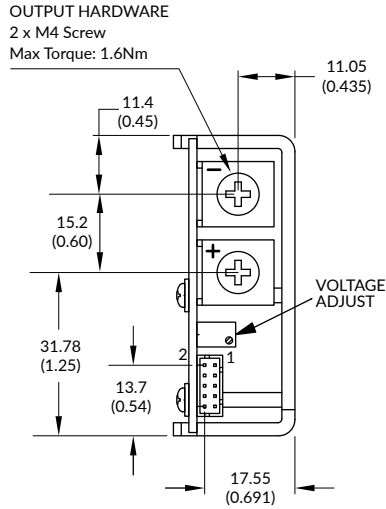

2 Slot Modules

(1R/2R Peak)

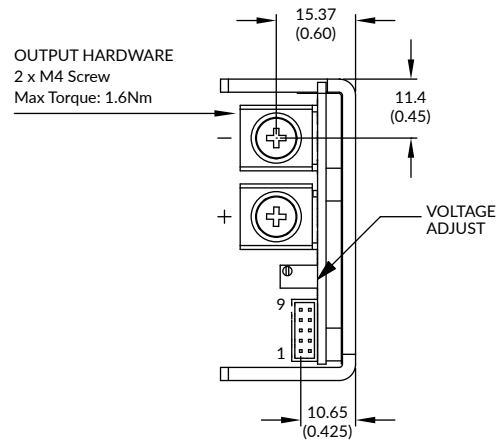

3 Slot Modules

(3R Peak)

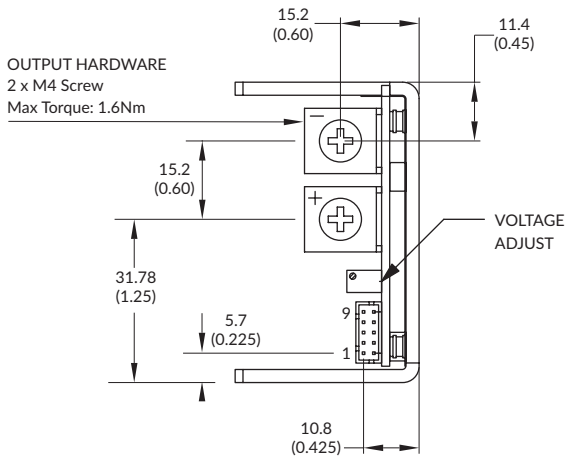

4 Slot Modules

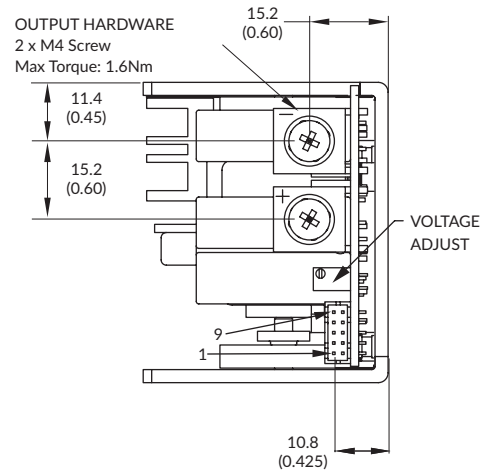

Single Output: Module Logic Connector Pinouts

Pin	Function	Pin	Function
1	Sense +	6	Inhibit
2	Sense -	7	Module Inhibit Return
3	V Prog	8	DC OK Collector
4	I Share	9	DC OK Emitter
5	Not Used	10	Not Used

Notes:

1. All dimensions in mm (inches). Tolerance: .xx = ±0.50 (±0.02) .xxx = ±0.25 (±0.01)
2. Weight: 2/2R Slot: 218g (0.48lb) approx, 3 Slot: 335g (0.74lb) approx. 4 Slot: 431g (0.95lb) approx.

3. Mating plug: JST part no. PHDR-10VS.
4. Contact: 26-22 AWG JST part no. SPHD-001T-P0.5.
5. Connector kit available order part no. fleXPower CONKIT.

XTL15 fleXPower Series



Module Mechanical Details

Dual Output 2 Slot Modules

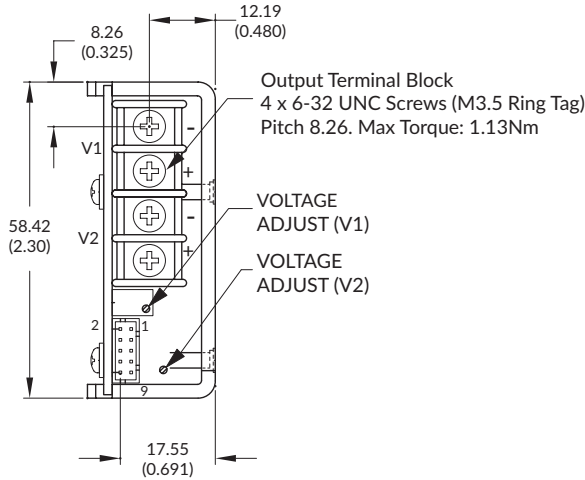

Dual Output: Module Logic Connector Pinouts			
Pin	Function	Pin	Function
1	V1 Sense +	6	Inhibit
2	V1 Sense -	7	Module Inhibit Return
3	Not used	8	DC OK Collector
4	Not used	9	DC OK Emitter
5	V2 Sense +	10	V2 Sense -

Notes:

- All dimensions in mm (inches). Tolerance: .xx = ±0.50 (±0.02); .xxx = ±0.25 (±0.01).
- Weight: 218g (0.48lb) approx.
- Mating plug: JST part no. PHDR-10VS.
- Contact: 26-22 AWG JST part no. SPHD-001T-P0.5.
- Connector kit available order part no. fleXPower CONKIT.

Fan Speed Control Module 2 Slot Modules

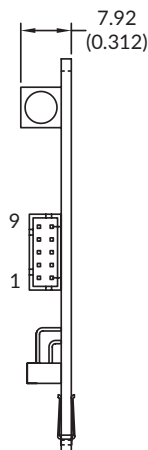

Fan Speed Control Module Connector Pinouts			
Pin	Function	Pin	Function
1	Fan Fail	6	Not used
2	Fan Fail	7	Not used
3	Not used	8	Not used
4	Not used	9	Ground
5	Not used	10	Ground

Notes:

- All dimensions in mm (inches). Tolerance: .xx = ±0.50 (±0.02); .xxx = ±0.25 (±0.01).
- Weight: 45g (0.10lb) approx.
- Mating plug: JST part no. PHDR-10VS.
- Contact: 26-22 AWG JST part no. SPHD-001T-P0.5.
- Connector kit available order part no. fleXPower CONKIT.

XTL15 fleXPower Series



Mechanical Details

XTL15 Chassis

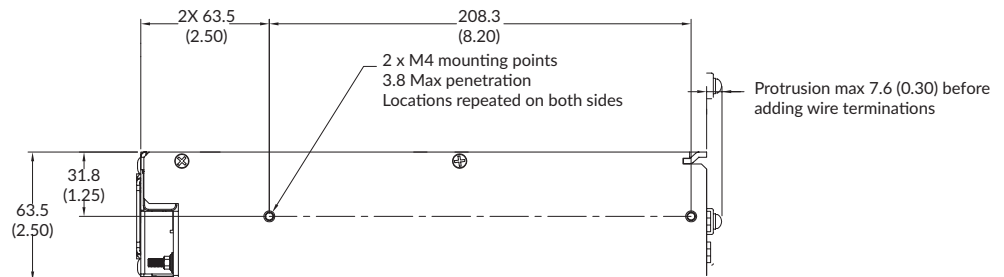
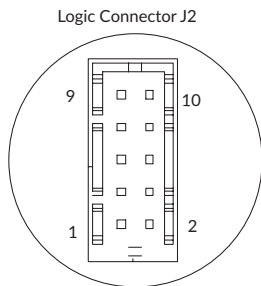
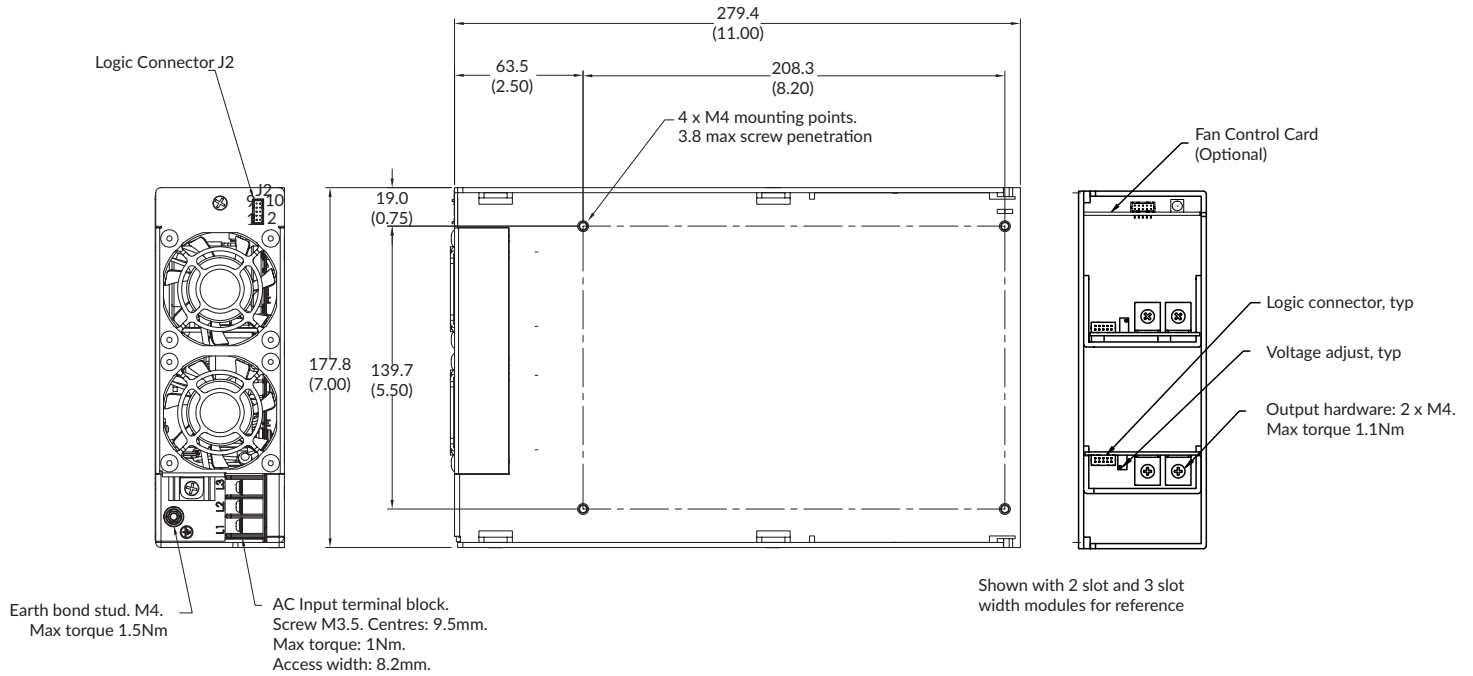

J2 Logic Connector			
JST Part no. S10B-PHDSS(LF)			
Pin	Function	Pin	Function
1	Global Inhibit Return	6	Global AC OK Collector
2	Global Inhibit	7	5V Standby
3	Global DC OK Emitter	8	5V Standby Return
4	Global DC OK Collector	9	Manufacturer Use Only
5	Global AC OK Emitter	10	Manufacturer Use Only

Specification subject to change without notice

Notes:

- All dimensions in mm (inches).
Tolerance: .xx = ±0.50 (±0.02); .xxx = ±0.25 (±0.01).
- Weight: 1.91kg (4.32lb) approx.

- Logic Connector:
Mating plug: JST part no. PHDR-10VS.
Contact: 26-22 AWG JST part no. SPHD-001T-P0.5.

- Fan Fail Connector:
Mating plug: JST part no. PHR-2
Contact: 30-24 AWG JST part no. SPH-002T-P0-5S