

85W

EXTERNAL
DESK TOP

AC-DC
power supplies



The ALM85 has both medical (2 x MOPP) and ITE safety approvals, available as class I, or class II construction with a smooth wipe clean IP32 sealed case that is ideal for medical applications.

The standard class I version has an IEC320-C14 inlet, the class II version with suffix C2-8 has a polarized IEC320-C8 inlet.



Features

- ▶ Regulated single outputs 12V to 24VDC
- ▶ Medical & ITE safety approvals
- ▶ Energy efficiency level VI
- ▶ EU CoC tier 2 compliant
- ▶ 4th edition medical EMC
- ▶ IP32 environmental rating
- ▶ Class I & class II versions
- ▶ <0.15W standby power
- ▶ Low earth leakage current
- ▶ 0°C to +60°C operation
- ▶ 3 year warranty

Applications



Medical
Diagnostics



Home
Healthcare



Healthcare

Dimensions

135.0 x 62.0 x 37.0mm (5.31" x 2.44" x 1.45")

Models & ratings

Model number ^(1,2)	Output voltage	Output current	Total regulation	Output power
ALM85PS12	12.0VDC	6.67A	±5%	80W
ALM85PS15	15.0VDC	5.33A		
ALM85PS19	19.0VDC	4.47A		85W
ALM85PS24	24.0VDC	3.54A		

Notes:

1. For class II versions, add suffix 'C2-8' to the end of the part number e.g. ALM85US24C2-8.
2. For optional input connector retention clip add suffix '-A' to the model number, e.g. ALM85US24-A (not available for C2 versions)

Input

Characteristic	Minimum	Typical	Maximum	Units	Notes & conditions
Input voltage	80		264	VAC	Derate linearly from 100% load at 90VAC to 80% load at 80VAC. 300VAC/5s maximum
Input frequency	47		63	Hz	
Input current		1.7/0.9		A	Measured at 115/230VAC
Inrush current			60/120	A	115/230VAC, cold start at +25°C
Power factor					EN61000-3-2 Class A
Earth leakage current			250	μA	264VAC, 60Hz
No load input power			0.15	W	
Input protection	T3.15A/250 VAC internal fuse in both line & neutral				

Output

Characteristic	Minimum	Typical	Maximum	Units	Notes & conditions
Output voltage	12		24	VDC	See models and ratings table
Initial set accuracy			±2	%	At 50% load
Minimum load	No minimum load required				
Start up delay			2	s	
Start up rise time			150	ms	
Hold up time	10/20			ms	Full load and 115/230VAC
Line regulation			±0.5	%	
Total regulation			±5	%	
Transient response			4	%	Maximum deviation, recovering to less than 1% within 500μs for 25% step load
Ripple and noise			1.5	% pk-pk	Measured with 20MHz bandwidth and 10μF electrolytic in parallel with 0.1μF ceramic capacitor.
Overshoot			10	%	At turn on / turn off
Overload protection	115		175	%	
Overvoltage protection			150	%	Recycle mains to reset
Short circuit protection	Trip and restart (hiccup), auto resetting				
Thermal protection	Measured internally, auto resetting				
Temperature coefficient		0.02		%/°C	
Standby leakage current			95	μA	264VAC, 60Hz

General

Characteristic	Minimum	Typical	Maximum	Units	Notes & conditions
Efficiency	88			%	See models and ratings table and curves.
Isolation			4000	VAC	2 x MOPP
			1500	VAC	1 x MOPP (Class I versions only)
			500	VAC	Class I versions only
Switching frequency		65		kHz	PWM
Power density		0.277 (4.45)		cm ³ (W/in ³)	
Mean time between failure		>300		khrs	MIL-HDBK-217F at 25°C GB
Weight		355 (0.78)		g (lb)	

Environmental

Characteristic	Minimum	Typical	Maximum	Units	Notes & conditions
Operating Temperature	0		+60	°C	Derate from 100% load at 40°C to 30% load at 60°C
Cooling	Natural convection				
Operating Humidity	5		95	%RH	Non-condensing
Storage Temperature	-20		+80	°C	
Operating Altitude			5000	m	
Shock	IEC68-2-27, 30g, 11ms half sine, 3 times in each of 6 axes				
Vibration	IEC68-2-6, 10-500Hz, 2g 10 mins/sweep, 60 mins for each of 3 axes				

Emissions - EMC

Phenomenon	Standard	Test level	Notes & conditions
Emissions	EN55011, EN55032	Level B	Conducted and radiated
Harmonic currents	EN61000-3-2	Class A	
Voltage flicker	EN61000-3-3		

Emissions - immunity

Phenomenon	Standard	Test level	Criteria	Notes & conditions
ESD immunity	EN61000-4-2	3	A	±15kV air/±8kV contact
Radiated immunity	EN61000-4-3	10V/m	A	80-2700MHz. IEC60601-1-2 Ed.4 at other frequencies
EFT/burst	EN61000-4-4	3	A	
Surge	EN61000-4-5	Installation class 3	A	
Conducted	EN61000-4-6	10V	A	
Magnetic fields	EN61000-4-8	4	A	
Dips and interruptions	EN61000-4-11	Dip: 30% 500ms	A/B	High line/low line
		Dip: 60% 200ms	A/B	High line/low line
		Dip: 80% 5000ms	B	
		Int: 100% 10ms	A	
		Int: 100% 20ms	A	
	EN60601-1-2	Dip: 30% 25 AC Cycles	A	230VAC 100% load, 100VAC 80%
		Dip: 60% 5 AC Cycles	A	230VAC 100% load, 100VAC 30%
		Int: 100% 0.5 AC Cycles	A	
		Int: 100% 1.0 AC Cycles	A	230VAC 100% load, 100VAC 50%
		Int: 100% 250 AC Cycles	B	

Safety approvals

Safety agency	Standard	Notes & conditions
UL	UL62368-1	Information technology
EN	EN62368-1	Information technology
	EN60601-1	Medical
CB	IEC62368-1, IEC60950-1	Information technology
	IEC60601-1	Medical
Others	CSA C22.2 No. 60601, CCC, PSE, KC & RCM	May require additional importer information
CE	Meets all applicable legislation	
UKCA	Meets all applicable legislation	

Derating curve

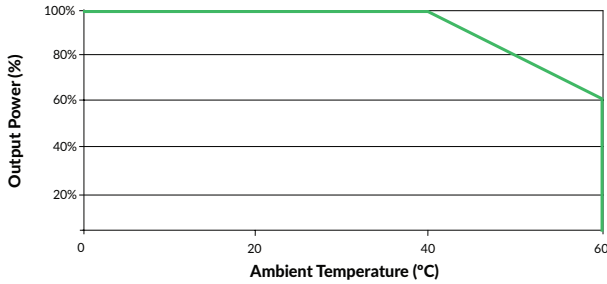

Efficiency curve

ALM85US12

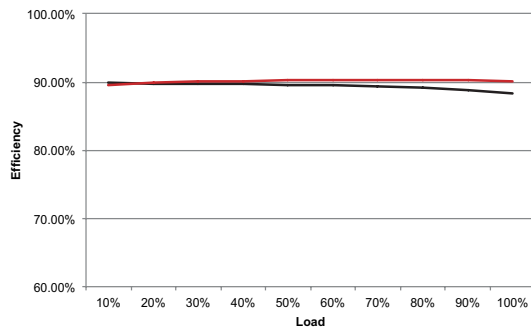

ALM85US24

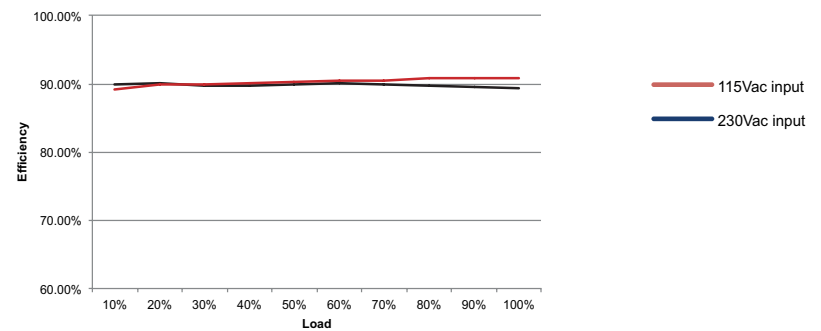

Mechanical details

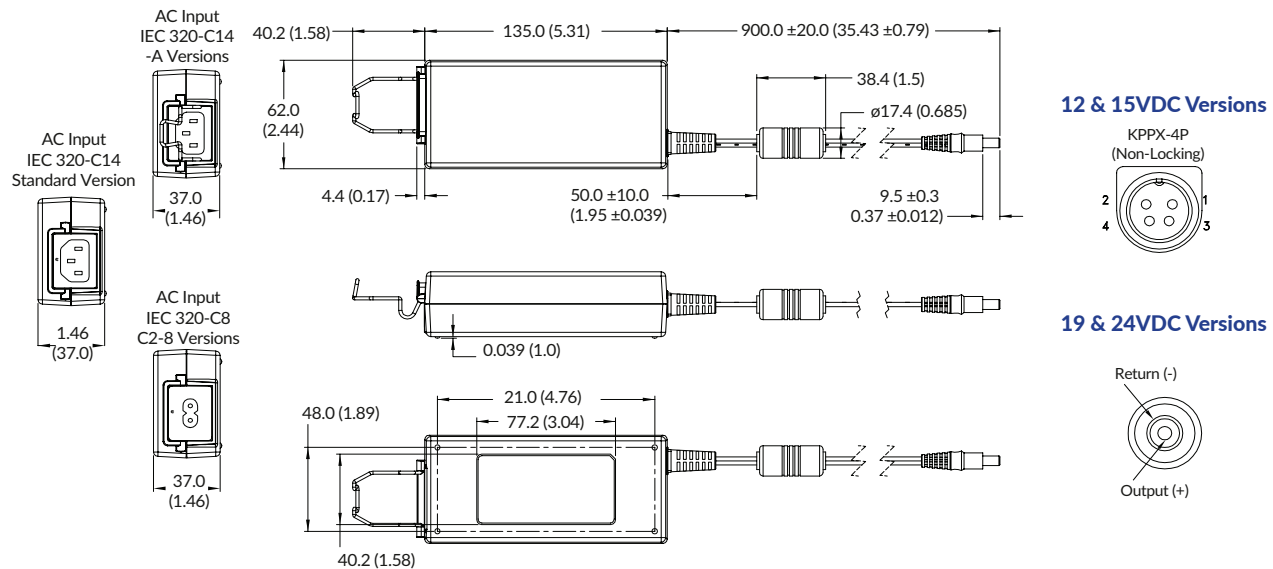

Pin	Connection
1	+Vout
2	+Vout
3	RTN
4	RTN
Shell	Not connected

Notes:

- All dimensions shown in mm (inches). Tolerance is 0.5 (0.02) maximum, except output cable length.
- Weight: 355g (0.78lbs) approx.
- For European mains lead order part EU-MAINS-IEC for C14 versions, or EU-MAINS-8 for C8 versions.
- For UK mains lead order part UK-MAINS-IEC for C14 versions, or UK-MAINS-8 for C8 versions.
- For US mains lead order part US-MAINS-IEC for C14 versions, or US-MAINS-8 for C8 versions.
- Output connector: 12VDC & 15VDC: 4 pin power din with pin 1 & 2 - positive and pin 3 & 4 - return, equivalent to KPPX-4P (non-locking). 19VDC & 24VDC: DC barrel jack; 5.5mm outer diameter, 2.5mm inner diameter with centre positive.

Specifications subject to change without notice.