

### 20 Watts

- Regulated single & dual outputs from 3.3V to 30VDC
- Wide 4:1 input range
- Chassis mount with optional DIN rail clip
- UL62368-1 safety approvals
- EN55032 class A with no external components
- Remote on/off & voltage trim function
- 3kVDC isolation
- -40 °C to +100°C operating temperature
- Full power to 70°C
- 3 year warranty

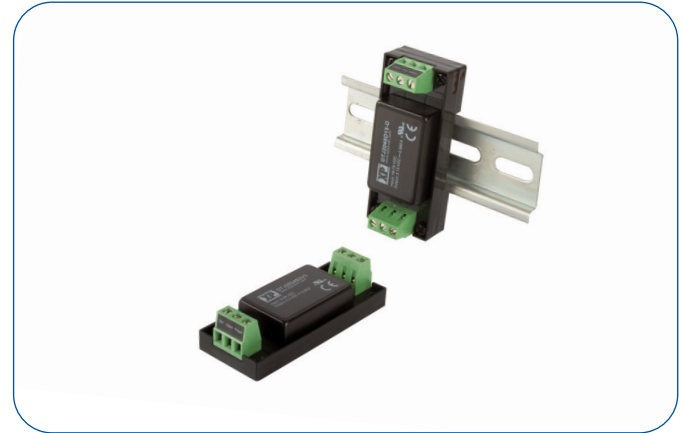

#### Dimensions:

##### DTJ20:

3.00 x 1.24 x 0.77" (76.2 x 31.4 x 19.4 mm)

The DTJ series of chassis mount DC-DC power supplies allows for easy and convenient integration into a variety of industrial and commercial applications. The DC-DC power solution is constructed using lightweight materials and includes features such as short circuit protection, input reverse polarity protection and soft start. The wide input range covers nominal voltages of 12V, 24V and 48V.

### Models & Ratings

Input Voltage	Output Voltage	Output Current	Input Current <sup>(1,5)</sup>		Maximum Capacitive Load <sup>(6)</sup>	Efficiency <sup>(2)</sup>	Model Number <sup>(3,4)</sup>
			No Load	Full Load			
24V (9-36V)	3.3V	5.50 A	10 mA	859 mA	10000 µF	88%	DTJ2024S3V3
	5.0V	4.00 A	10 mA	947 mA	6800 µF	88%	DTJ2024S05
	12.0V	1.67 A	10 mA	954 mA	1000 µF	87%	DTJ2024S12
	15.0V	1.33 A	15 mA	955 mA	680 µF	87%	DTJ2024S15
	±5.0V	±2.00 A	10 mA	980 mA	±2200 µF	85%	DTJ2024D05
	±12.0V	±0.835 A	15 mA	954 mA	±470 µF	87%	DTJ2024D12
48V (18-75V)	±15.0V	±0.665 A	15 mA	950 mA	±330 µF	87%	DTJ2024D15
	3.3V	5.50 A	8 mA	427 mA	10000 µF	88%	DTJ2048S3V3
	5.0V	4.00 A	8 mA	468 mA	6800 µF	89%	DTJ2048S05
	12.0V	1.67 A	8 mA	469 mA	1000 µF	89%	DTJ2048S12
	15.0V	1.33 A	8 mA	462 mA	680 µF	90%	DTJ2048S15
	±5.0V	±2.00 A	8 mA	485 mA	±2200 µF	86%	DTJ2048D05
	±12.0V	±0.835 A	8 mA	469 mA	±470 µF	89%	DTJ2048D12
	±15.0V	±0.665 A	10 mA	464 mA	±330 µF	89%	DTJ2048D15

### Notes

1. Input current measured at nominal input voltage.
2. Typical values.
3. For optional version fitted with DIN Clip add suffix '-D' e.g. DTJ2024S12-D.
4. For optional factory fitted heatsink add suffix '-HK' e.g. DTJ2024S12-HK or DTJ2024S12-HKD with DIN clip.
5. Input current is typically 2.0mA at nominal input voltage when output is remotely turned off.
6. Per output.

### Input

Characteristic	Minimum	Typical	Maximum	Units	Notes & Conditions
Input Voltage Range	9		36	VDC	12 V & 24 V nominal input voltage
	18		75	VDC	24 V & 48 V nominal input voltage
Input Current					See Models and Ratings table
Inrush Current		35/45		A	DTJ2024 / DTJ2048 series
Reflected Ripple Current		20		mAp-p	Measured with 12µH and 47µF source values
Input Filter	Pi type				
Undervoltage Lockout	On at >8.8V Off <8.0 V				DTJ2024 series
	On at >17.5V Off <16.0 V				DTJ2048 series
Input Surge			50	VDC	DTJ2024 series for 100 ms
			100	VDC	DTJ2048 series for 100 ms
Reverse Polarity	Integrated protection				
Remote On/Off (positive logic)	On: Logic High (3.0-12 V) or open circuit pin 1.				
	Off: Logic Low (<1.2 V) or short pin 2 to pin 1.				
	Idle Current: 2 mA, typical				

### Output

Characteristic	Minimum	Typical	Maximum	Units	Notes & Conditions
Output Voltage	3V3		30	V	See models and ratings table
Output Voltage Trim			±10	%	See application notes
Initial Set Accuracy			±3	%	At full load
Minimum Load	0			A	No minimum load required
Start Up Delay		30		ms	At nominal input voltage
Line Regulation			±0.5	%	From minimum to maximum input voltage
Load Regulation			±0.5/±1.0	%	0 - 100% load. single/dual with balanced load
Cross Regulation			±5	%	On dual output models with one output at 25% load and the other varied from 10% to 100% load.
Transient Response			±8/±5	% deviation	3.3V single output / All other models. Recovery to within 1% in <250 µs for a 25% load change
Ripple & Noise			75	mV pk-pk	Single output. 20MHz bandwidth with 10µF/25V MLCC
			60		Dual output. 20MHz bandwidth with 10µF/25V MLCC
Short Circuit Protection					Continuous. Trip (hiccup mode), auto recovery
Overload Protection		170		%	Trip & restart (hiccup mode)
Overvoltage Protection		140		%Vout	Internal voltage clamp
Temperature Coefficient			±0.02	%/°C	

### General

Characteristic	Minimum	Typical	Maximum	Units	Notes & Conditions
Efficiency		88		%	See Models and Ratings table
Isolation	3000			VDC	For 60 s functional
Isolation Resistance	1000			MΩ	
Input to Output Capacitance		2000		pF	
Switching Frequency		270/330		kHz	3.3 & 5V single output / All other models
Mean Time Between Failure	380			kHrs	MIL-HDBK-217F, +25 °C GB
Case Material	Non conductive, black plastic UL94V-0. Power module copper case with epoxy potting UL94V-0				
Weight		0.099 (45.0)		lb (g)	DIN rail option add 0.011lbs (5.0g) Heatsink option add 0.014lbs (6.5g)

### Environmental

Characteristic	Minimum	Typical	Maximum	Units	Notes & Conditions
Operating Temperature	-40		+100	°C	See derating curves
Storage Temperature	-55		+125	°C	
Case Temperature			+105	°C	
Thermal Impedance to Air	12			°C/W	With heatsink 11°C/W
Humidity	5		95	%RH	Non-condensing
Cooling					Natural convection, 20 LFM
Altitude			5000	m	Operating

### EMC: Emissions

Phenomenon	Standard	Test Level	Notes & Conditions
Conducted	EN55032	Class A	
Radiated	EN55032	Class A	

### EMC: Immunity

Phenomenon	Standard	Test Level	Criteria	Notes & Conditions
Immunity	EN55035			
ESD Immunity	EN61000-4-2	±6 kV Contact, ±8 kV Air	B	
Radiated Immunity	EN61000-4-3	10 V/m	A	
EFT/Burst	EN61000-4-4	±2 kV	A	Requires additional 330µF, 100V capacitor across input terminals
Surges	EN61000-4-5	±2 kV	A	
Conducted Immunity	EN61000-4-6	10 Vrms	A	
Magnetic Fields	EN61000-4-8	100 A/m	A	

### Safety Approvals

Safety Agency	Safety Standard	Notes & Conditions
UL	UL60950-1/62368-1	
CE	Meets all applicable directives	
UKCA	Meets all applicable legislation	

### Application Notes

#### Derating Curve for Convection Cooling

##### Without Heatsink

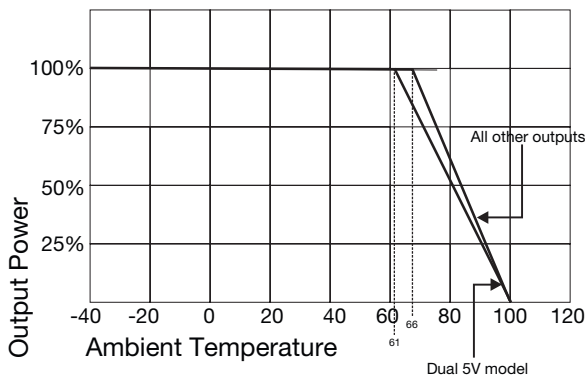

##### With Heatsink

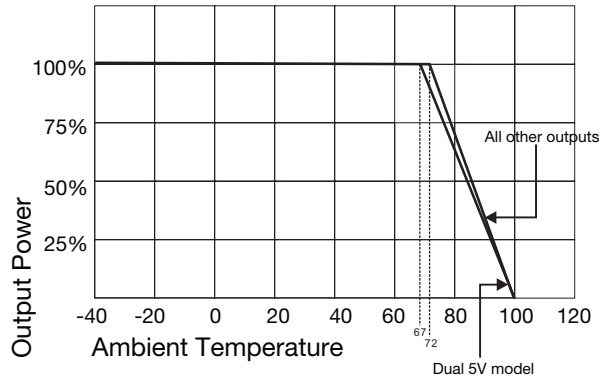

#### External Output Trimming

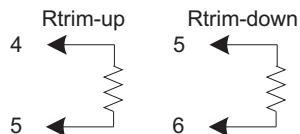

Output can be externally trimmed by using the method as below, (single output models only)

#### Trim Down Resistor Values

Model	1%	2%	3%	4%	5%	6%	7%	8%	9%	10%
3V3	309.0 k	165.4 k	105.6 k	72.9 k	52.3 k	38.0 k	27.6 k	19.7 k	13.5 k	8.40 k
5V	119.9 k	77.70 k	50.50 k	35.2 k	25.3 k	18.4 k	13.4 k	9.50 k	6.40 k	3.90 k
12V	345.0 k	138.1 k	79.90 k	51.5 k	34.6 k	23.4 k	15.5 k	9.50 k	4.90 k	1.26 k
15V	174.4 k	91.10 k	56.60 k	37.7 k	25.8 k	17.6 k	11.6 k	7.00 k	3.50 k	0.55 k

#### Trim Up Resistor Values

Model	1%	2%	3%	4%	5%	6%	7%	8%	9%	10%
3V3	537.7 k	177.1 k	96.40 k	60.8 k	40.8 k	27.9 k	19.0 k	12.4 k	7.30 k	3.40 k
5V	635.2 k	170.0 k	92.80 k	61.1 k	43.8 k	32.9 k	25.4 k	20.0 k	15.8 k	12.5 k
12V	367.4 k	179.6 k	113.6 k	79.9 k	59.5 k	45.8 k	35.9 k	28.5 k	22.7 k	18.1 k
15V	661.5 k	231.3 k	134.0 k	91.0 k	66.8 k	51.3 k	40.4 k	32.5 k	26.4 k	21.5 k

### Mechanical Details

#### Chassis Mount

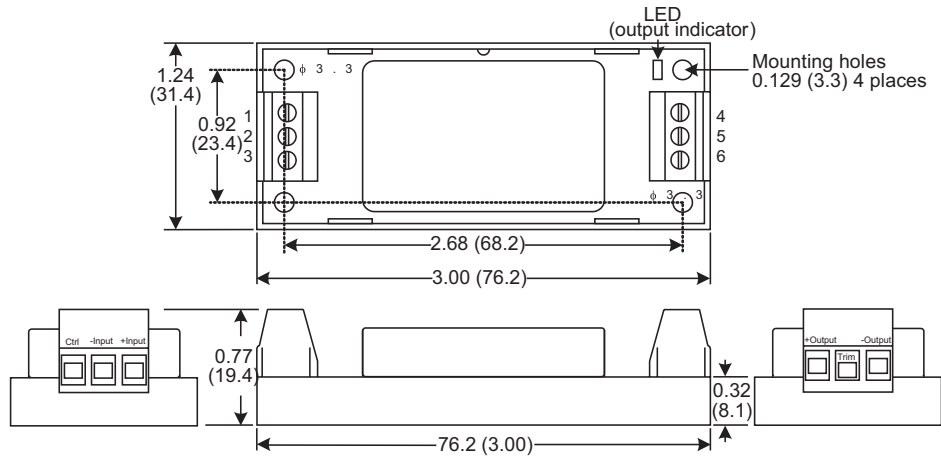

#### Chassis Mount with Heatsink -HK

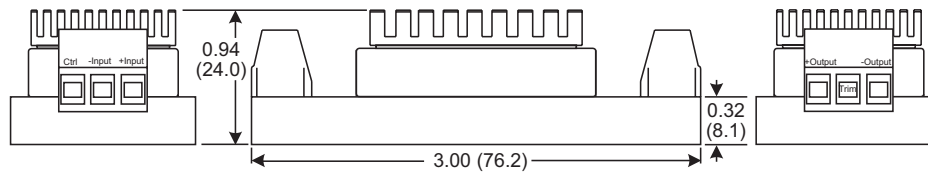

#### DIN Rail -D

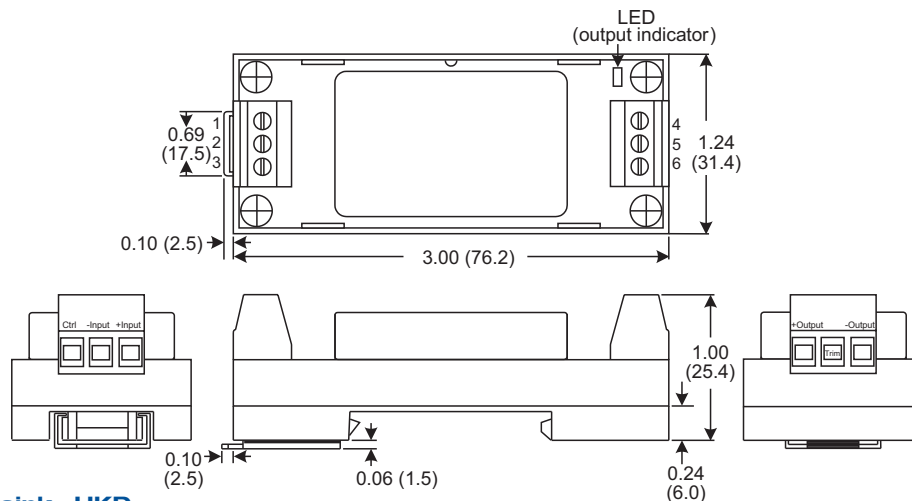

#### DIN Rail with Heatsink -HKD

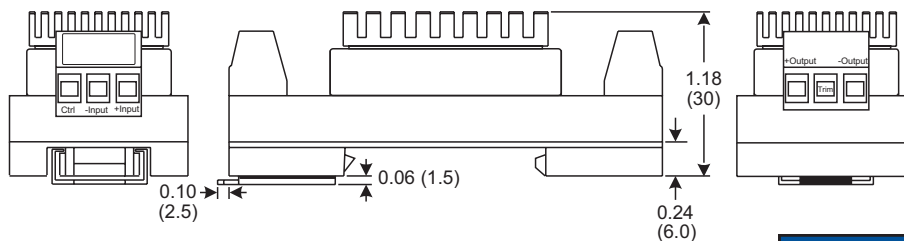

#### Notes

1. All dimensions are in inches (mm)
2. Weight: 0.099 lbs (45 g) approx
3. Weight for -D version: 0.121 lbs (55 g) approx
4. Terminal wire size 24 ~12 AWG
5. Screw terminal torque 7 lb-in (0.79 Nm)
6. Case tolerance:  $\pm 0.02$  ( $\pm 0.5$ )
7. Mounting rail: TS35
8. Heatsink is aluminium black anodic
9. Heatsink weight 0.014 (6.5g)

Pin Connections		
Pin	Single Output	Dual Output
1	Remote On/Off	Remote On/Off
2	-Vin	-Vin
3	+Vin	+Vin
4	-Vout	-Vout
5	Trim	Common
6	+Vout	+Vout

Specifications subject to change without notice.