

Designed with bipolar outputs for MOSFET & IGBT drives, the IHA01 series is housed in a DIP24 plastic case for PCB mounting.

Featuring a $\pm 10\%$ input voltage range for 5, 9, 12, 15 & 24VDC nominal inputs, offering both single and dual outputs, singles have 3.3, 5, 9, 12 & 15VDC with duals having ± 3.3 , ± 5 , ± 9 , ± 12 , ± 15 & $\pm 15/-9$ VDC. The 1W IHA01 provides 6.0kVDC isolation between input and output as standard, the output has short circuit protection. The operating temperature range is from -40°C to $+85^{\circ}\text{C}$.

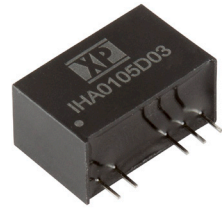

Features

- ▶ Unregulated single & dual outputs
- ▶ $\pm 10\%$ input range
- ▶ Single outputs 3.3 to 15VDC
- ▶ Dual outputs ± 3.3 to ± 15 VDC
- ▶ SIP7 package
- ▶ High 6.0kVDC isolation
- ▶ 250VAC working voltage
- ▶ Bipolar outputs for MOSFET and IGBT drives
- ▶ -40°C to $+85^{\circ}\text{C}$ operating temperature
- ▶ Full load to $+85^{\circ}\text{C}$
- ▶ 3 year warranty

Applications



Dimensions

19.5 x 9.8 x 12.5mm (0.77" x 0.39" x 0.49")

Models & ratings

Model number	Input voltage	Output voltage	Output current	Efficiency	Input current		Maximum capacitive load
					No load	Full load	
IHA0105S3V3	4.5-5.5VDC	3.3VDC	303mA	71%	30mA	280mA	220 μ F
IHA0105S05		5.0VDC	200mA	75%	30mA	265mA	220 μ F
IHA0105S09		9.0VDC	111mA	77%	30mA	260mA	220 μ F
IHA0105S12		12.0VDC	83mA	76%	45mA	265mA	220 μ F
IHA0105S15		15.0VDC	67mA	77%	40mA	260mA	220 μ F
IHA0105D03		± 3.3 VDC	± 151 mA	73%	30mA	275mA	± 100 μ F
IHA0105D05		± 5.0 VDC	± 100 mA	75%	30mA	265mA	± 100 μ F
IHA0105D09		± 9.0 VDC	± 56 mA	77%	30mA	260mA	± 100 μ F
IHA0105D12		± 12.0 VDC	± 42 mA	76%	45mA	265mA	± 100 μ F
IHA0105D15		± 15.0 VDC	± 33 mA	77%	40mA	260mA	± 100 μ F
IHA0105D1509		$\pm 15/-9$ VDC	± 33 mA / -55 mA	76%	40mA	265mA	± 100 μ F

Continued on page 2

Notes:

Input currents measured at nominal input voltage.

Models & ratings

Model number	Input voltage	Output voltage	Output current	Efficiency	Input current		Maximum capacitive load
					No load	Full load	
IHA0109S3V3	8.1-9.9VDC	3.3VDC	303mA	72%	20mA	155mA	220µF
IHA0109S05		5.0VDC	200mA	77%	25mA	145mA	220µF
IHA0109S09		9.0VDC	111mA	79%	25mA	140mA	220µF
IHA0109S12		12.0VDC	83mA	77%	25mA	145mA	220µF
IHA0109S15		15.0VDC	67mA	79%	25mA	140mA	220µF
IHA0109D03		±3.3VDC	±151mA	73%	25mA	155mA	±100µF
IHA0109D05		±5.0VDC	±100mA	75%	25mA	150mA	±100µF
IHA0109D09		±9.0VDC	±56mA	79%	25mA	140mA	±100µF
IHA0109D12		±12.0VDC	±42mA	77%	25mA	145mA	±100µF
IHA0109D15		±15.0VDC	±33mA	79%	25mA	140mA	±100µF
IHA0109D1509		+15/-9VDC	+33 mA / -55mA	78%	25mA	140mA	±100µF
IHA0112S3V3	10.8-13.2VDC	3.3VDC	303mA	70%	20mA	120mA	220µF
IHA0112S05		5.0VDC	200mA	73%	20mA	115mA	220µF
IHA0112S09		9.0VDC	111mA	77%	20mA	110mA	220µF
IHA0112S12		12.0VDC	83mA	73%	20mA	115mA	220µF
IHA0112S15		15.0VDC	67mA	76%	20mA	110mA	220µF
IHA0112D03		±3.3VDC	±151mA	72%	20mA	115mA	±100µF
IHA0112D05		±5.0VDC	±100mA	73%	20mA	115mA	±100µF
IHA0112D09		±9.0VDC	±56mA	77%	20mA	110mA	±100µF
IHA0112D12		±12.0VDC	±42mA	74%	20mA	115mA	±100µF
IHA0112D15		±15.0VDC	±33mA	76%	20mA	110mA	±100µF
IHA0112D1509		+15/-9VDC	+33 mA / -55mA	76%	20mA	110mA	±100µF
IHA0115S3V3	13.5-16.5VDC	3.3VDC	303mA	73%	15mA	91mA	220µF
IHA0115S05		5.0VDC	200mA	77%	15mA	87mA	220µF
IHA0115S09		9.0VDC	111mA	80%	15mA	83mA	220µF
IHA0115S12		12.0VDC	83mA	80%	15mA	83mA	220µF
IHA0115S15		15.0VDC	67mA	79%	15mA	84mA	220µF
IHA0115D03		±3.3VDC	±151mA	75%	15mA	89mA	±100µF
IHA0115D05		±5.0VDC	±100mA	79%	15mA	84mA	±100µF
IHA0115D09		±9.0VDC	±56mA	81%	15mA	82mA	±100µF
IHA0115D12		±12.0VDC	±42mA	80%	15mA	83mA	±100µF
IHA0115D15		±15.0VDC	±33mA	80%	15mA	83mA	±100µF
IHA0115D1509		+15/-9VDC	+33 mA / -55mA	84%	12mA	79mA	±100µF
IHA0124S3V3	21.6-26.4VDC	3.3VDC	303mA	70%	15mA	60mA	220µF
IHA0124S05		5.0VDC	200mA	71%	15mA	59mA	220µF
IHA0124S09		9.0VDC	111mA	70%	15mA	60mA	220µF
IHA0124S12		12.0VDC	83mA	72%	15mA	58mA	220µF
IHA0124S15		15.0VDC	67mA	73%	15mA	57mA	220µF
IHA0124D03		±3.3VDC	±151mA	68%	10mA	61mA	±100µF
IHA0124D05		±5.0VDC	±100mA	69%	15mA	60mA	±100µF
IHA0124D09		±9.0VDC	±56mA	73%	15mA	57mA	±100µF
IHA0124D12		±12.0VDC	±42mA	72%	15mA	58mA	±100µF
IHA0124D15		±15.0VDC	±33mA	75%	15mA	56mA	±100µF
IHA0124D1509		+15/-9VDC	+33 mA / -55mA	74%	15mA	56mA	±100µF

Notes:

Input currents measured at nominal input voltage.

Input

Characteristic	Minimum	Typical	Maximum	Units	Notes & conditions
Input voltage range	4.5		5.5	VDC	5VDC nominal
	8.1		9.9		9VDC nominal
	10.8		13.2		12VDC nominal
	13.5		16.5		15VDC nominal
	21.6		26.4		24VDC nominal
Input reflected ripple		20		mA pk-pk	Through 12 μ H inductor and 47 μ F capacitor
Input surge			7	VDC for 100ms	5VDC nominal
			12		9VDC nominal
			15		12VDC nominal
			18		15VDC nominal
			28		24VDC nominal

Output

Characteristic	Minimum	Typical	Maximum	Units	Notes & conditions
Output voltage	3.3		30	VDC	See models and ratings table
Initial set accuracy			± 3	%	At full load
Minimum load	10			%	Minimum load required to meet specified regulation
Line regulation			± 1.2	% / 1%	Output changes by max of 1.2% for each 1% change in input voltage
Load regulation			10	%	From 10% to full load, see application note
Cross regulation		± 4		% deviation	On dual output models, when one output is at 25% load and other is varied from 10% load to full load
Ripple & noise			200	mV pk-pk	20MHz bandwidth. Measured using 10 μ F electrolytic in parallel with 0.1 μ F ceramic capacitor
Short circuit protection	Continuous, auto recovery				
Maximum capacitive load	See models and ratings table				
Temperature coefficient			0.03	%/ $^{\circ}$ C	

General

Characteristic	Minimum	Typical	Maximum	Units	Notes & conditions
Efficiency		77		%	See models and ratings table
Isolation: input to output	6000			VDC	Functional (100% production test for 60s)
Isolation working voltage			250	VAC	400VDC
Isolation resistance	10 ⁹			Ω	
Isolation capacitance			10	pF	
Switching frequency	20		50	kHz	
Power density			0.41 (6.8)	W/cm ³ (W/in ³)	
Mean time between failure	2.39			Mhrs	MIL-HDBK-217F, +25 $^{\circ}$ C GB
Case material	Non-conductive black plastic with epoxy potting (UL94V-0 rated)				
Pin material	Alloy 42, solder coated nickel iron				
Potting material	Epoxy (UL94V-0)				
Solder process			260	$^{\circ}$ C	1.5mm from case, 10 s max.
Weight		4.2 (0.009)		g (lb)	

Environmental

Characteristic	Minimum	Typical	Maximum	Units	Notes & conditions
Operating temperature	-40		+85	°C	No thermal derating
Storage temperature	-40		+125	°C	
Case temperature			+100	°C	
Humidity	2.5		95	%RH	Non-condensing
Cooling	Natural convection				

Safety approvals

Safety agency	Standard	Notes & conditions
CE	Meets all applicable directives	
UKCA	Meets all applicable legislation	

Emissions - EMC

Phenomenon	Standard	Test level	Notes & conditions
Conducted	EN55022	Class B	See application notes
Radiated	EN55022	Class B	

Immunity - EMC

Phenomenon	Standard	Test level	Criteria	Notes & conditions
ESD Immunity	EN61000-4-2	±6/±8kV	A	Contact/air discharge
Radiated immunity	EN61000-4-3	10 Vrms	A	
EFT/Burst	EN61000-4-4	2kV	A	External components required, see application notes
Conducted immunity	EN61000-4-6	10 Vrms	A	
Magnetic fields	EN61000-4-8	1A/m	A	
CMTI		20kV/μs	A	1500VDC

Application notes

EFT filter

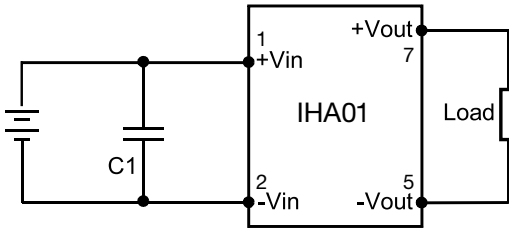

Input component C1 470 μ F 100V (e.g. Nippon Chemi-Con KY Series) is used to help meet EFT EN6100-4-4 test requirements for the module.

EMI filter

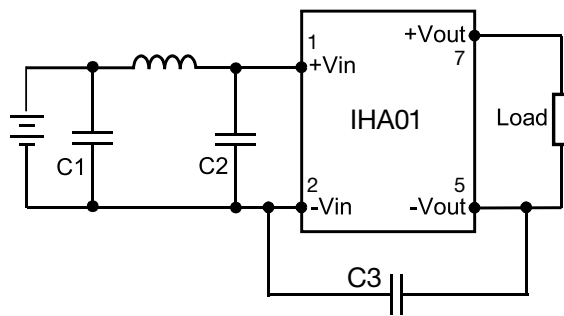

Model	C1	L	C2	C3
IHA0105XXXX	1206, 4.7 μ F / 50V	18 μ H		
IHA0109XXXX				
IHA0112XXXX				
IHA0115XXXX				
IHA0124XXXX			1210, 2.2 μ F / 100V	1206, 470pF / 2kV

Input filter components (C1,C2, C3 and L) are used to help meet conducted emissions requirements for the module. These components should be mounted as close as possible to the module, and all leads should be minimised to decrease radiated noise.

Regulation

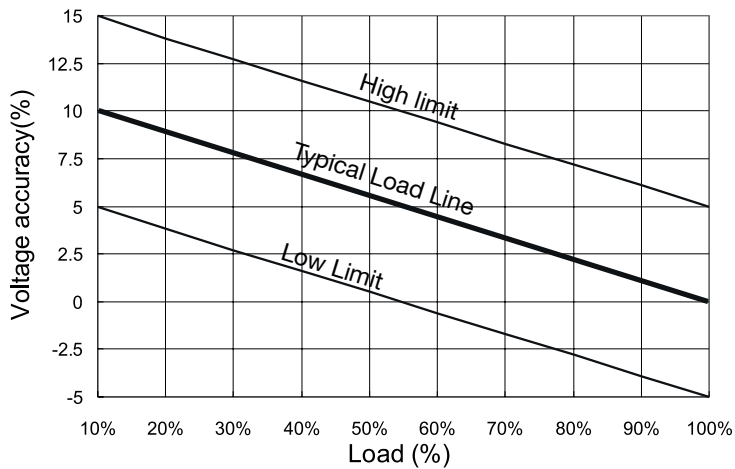

Mechanical details

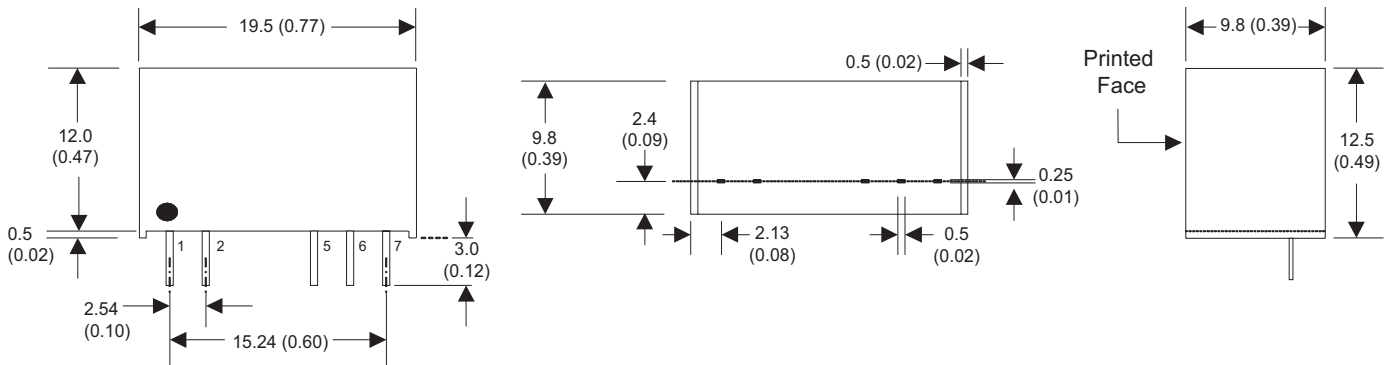

Pin connections

Pin	Single	
1	+Vin	+Vin
2	-Vin	-Vin
5	-Vout	-Vout
6	No Pin	Common
7	+Vout	+Vout

Notes:

- All dimensions are in mm (inches)
- Weight: 4.3 (0.009) g (lb) approx.
- Pin diameter: 0.5 ± 0.05 (0.02 ± 0.002)
- Pin pitch tolerance: ± 0.35 (± 0.014)
- Case tolerance: ± 0.5 (± 0.02)

Specifications subject to change without notice.