

3W

Convection cooled

DC-DC converters

The IZ series is housed in a SIP8 PCB mount plastic case. Featuring a 2:1 input voltage range of 4.5 to 9VDC, 9 to 18VDC, 18 to 36VDC or 36 to 72VDC with regulated single outputs of 3.3, 5, 12 & 15VDC and dual outputs ± 5 , ± 12 or ± 15 VDC.

The 3W IZ series has 1.6kVDC isolation between input and output. Remote On/Off and short circuit protection are standard. The operating temperature range is from -40°C to $+100^{\circ}\text{C}$, with derating above $+70^{\circ}\text{C}$.



Features

- ▶ Regulated single & dual outputs
- ▶ 2:1 input range
- ▶ Single outputs 3.3 to 15VDC
- ▶ Dual outputs ± 5.0 to ± 15 VDC
- ▶ SIP8 package
- ▶ 1.6kVDC isolation
- ▶ Remote On/Off
- ▶ -40°C to $+100^{\circ}\text{C}$ operating temperature
- ▶ Full power to $+70^{\circ}\text{C}$
- ▶ 3 year warranty

Applications

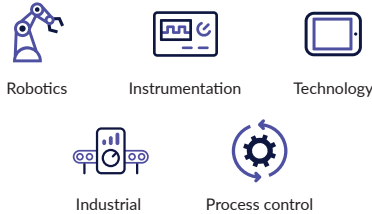

Dimensions

21.85 x 11.10 x 9.20mm (0.86" x 0.36" x 0.44")

Models & ratings

Model number ⁽¹⁾	Input voltage	No load input current ⁽²⁾	Output voltage	Output current	Efficiency	Maximum capacitive load
IZ0503SA	4.5-9.0VDC	65 mA	3.3VDC	700mA	74%	2200 μF
IZ0505SA		70 mA	5.0VDC	600mA	76%	1000 μF
IZ0512SA		75 mA	12.0VDC	250mA	82%	470 μF
IZ0515SA		75 mA	15.0VDC	200mA	82%	220 μF
IZ0505S		90 mA	± 5.0 VDC	± 300 mA	77%	± 470 μF
IZ0512S		90 mA	± 12.0 VDC	± 125 mA	81%	± 220 μF
IZ0515S		90 mA	± 15.0 VDC	± 100 mA	82%	± 100 μF

Continued on page 2

Notes:

1. Minimum load of 25% required to meet load regulation & ripple & noise specifications.
2. Measured at nominal input voltage.
3. Operation at no load will not damage the part but it may not meet all specifications.
4. When one output is set to 100% load and the other varies between 25-100% load.
5. Pin pitch tolerance: ± 0.35 (± 0.014)
6. Case tolerance: ± 0.5 (± 0.02)
7. Weight: SIP 3.9g (0.009lbs)
8. All dimensions in mm (inches)

Models & ratings

Model number ⁽¹⁾	Input voltage	No load input current ⁽²⁾	Output voltage	Output current	Efficiency	Maximum capacitive load
IZ1205SA	9.0-18.0VDC	35mA	5.0VDC	600mA	81%	1000µF
IZ1212SA		35mA	12.0VDC	250mA	84%	470µF
IZ1215SA		35mA	15.0VDC	200mA	84%	220µF
IZ1205S		45mA	±5.0VDC	±300mA	80%	±470µF
IZ1212S		45mA	±12.0VDC	±125mA	83%	±220µF
IZ1215S		45mA	±15.0VDC	±100mA	82%	±100µF
IZ2403SA	18.0-36.0VDC	15mA	3.3VDC	700mA	74%	2200µF
IZ2405SA		15mA	5.0VDC	600mA	79%	1000µF
IZ2412SA		20mA	12.0VDC	250mA	82%	470µF
IZ2415SA		20mA	15.0VDC	200mA	84%	220µF
IZ2405S		20mA	±5.0VDC	±300mA	80%	±470µF
IZ2412S		20mA	±12.0VDC	±125mA	83%	±220µF
IZ2415S	20mA	±15.0VDC	±100mA	83%	±100µF	
IZ4803SA	36.0-72.0VDC	10mA	3.3VDC	700mA	75%	2200µF
IZ4805SA		10mA	5.0VDC	600mA	78%	1000µF
IZ4812SA		15mA	12.0VDC	250mA	81%	470µF
IZ4815SA		15mA	15.0VDC	200mA	81%	220µF
IZ4805S		35mA	±5.0VDC	±300mA	78%	±470µF
IZ4812S		20mA	±12.0VDC	±125mA	80%	±220µF
IZ4815S	20mA	±15.0VDC	±100mA	81%	±100µF	

Notes:

- Minimum load of 25% required to meet load regulation & ripple & noise specifications.
- Measured at nominal input voltage.
- Operation at no load will not damage the part but it may not meet all specifications.
- When one output is set to 100% load and the other varies between 25-100% load.
- Pin pitch tolerance: ±0.35 (±0.014)
- Case tolerance: ±0.5 (±0.02)
- Weight: SIP 3.9g (0.009lbs)
- All dimensions in mm (inches)

Input

Characteristic	Minimum	Typical	Maximum	Units	Notes & conditions
Input voltage range		±10		%	
Input reflected ripple current		35		mA pk-pk	12µH inductor and 47µF capacitor, 5Hz to 20MHz
Input filter	Capacitor				

Output

Characteristic	Minimum	Typical	Maximum	Units	Notes & conditions
Output voltage	See models & ratings table				
Minimum load	0			%	No minimum load required
Line regulation			±0.5	%	
Load regulation			±1		25-100% load change
Setpoint accuracy			±1	%	
Ripple & noise		75		mV pk-pk	20 MHz bandwidth
Short circuit protection	Continuous with auto recover (foldback)				
Cross regulation		±5		%	Dual output models.
Temperature coefficient		±5			
Remote on/off	Module "on" if pin 3 is open circuit. Module "off" by driving 3-6mA into pin 3. Maximum applied voltage 9.7VDC relative to -Vin. See application note.				

General

Characteristic	Minimum	Typical	Maximum	Units	Notes & conditions
Efficiency	See models & ratings table				
Isolation voltage		1600		VDC	
Isolation resistance		10 ⁹		Ω	
Isolation capacitance		680		pF	
Isolation resistance		10 ⁹		Ω	
Switching frequency		100-650		kHz	
Mean time between failure		>1.34		Mhrs	MIL-HDBK-217F, +25°C GB

Environmental

Characteristic	Minimum	Typical	Maximum	Units	Notes & conditions
Operating temperature	-40		+100	°C	Derate from 100% load at +70°C to 0% load at +100°C
Storage temperature	-40		+125	°C	
Case temperature			+100	°C	
Cooling	Convection cooled				

Safety approvals

Certification	Standard	Notes & conditions
UL	UL60950-1, CAN/CSA C22.2 No.60950-1, UL62368-1	
CE	Meets all applicable directives	
UKCA	Meets all applicable legislation	

Mechanical details

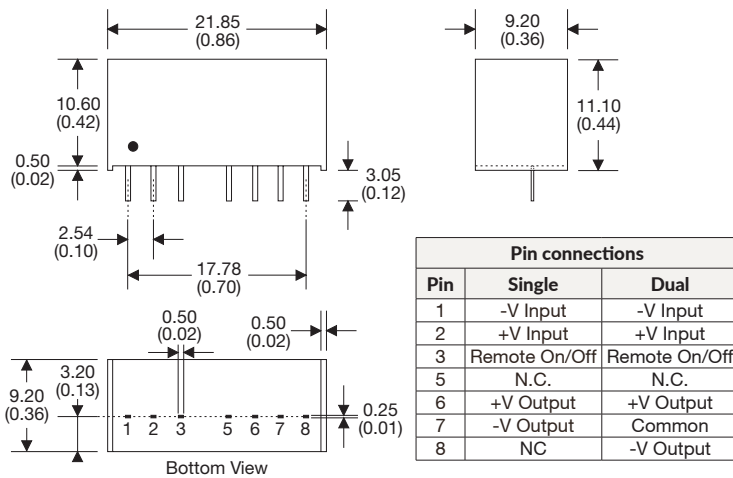

Application notes

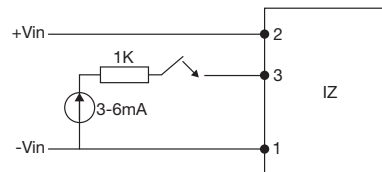

Notes:

- Minimum load of 25% required to meet load regulation & ripple & noise specifications.
- Measured at nominal input voltage.
- Operation at no load will not damage the part but it may not meet all specifications.
- When one output is set to 100% load and the other varies between 25-100% load.
- Pin pitch tolerance: ± 0.35 (± 0.014)
- Case tolerance: ± 0.5 (± 0.02)
- Weight: SIP 3.9g (0.009lbs)
- All dimensions in mm (inches)

Specifications subject to change without notice.