

10W



The wide input JTR10 series is available in two wide input 4:1 ranges: 9.0 to 36VDC for a 12 or 24VDC nominal supply; 18 to 75VDC for a 24 or 48VDC nominal supply. The regulated output is offered in four single and two dual output voltages: 3.3; 5.0; 12; 15; ± 12 & ± 15 VDC, the dual output versions could also be used to provide a single 24VDC or 30VDC output. For single output models, the output voltage is trimmable $\pm 10\%$ by external resistor. All models are high efficiency, up to 87%, there is no minimum load requirement, no-load current consumption is: 7mA (48V input models); 10mA (24V input models). The modules are fully protected against input undervoltage, short circuit and overload conditions.



The 10W JTR10 in its DIP16 package provides a significant reduction in size over the previous 10W DIP24 models. Suitable for ITE/industrial equipment, they are typically used in systems for: Portable & battery powered equipment; Communication systems; Robotics & many other applications.

Features

- ▶ Regulated single outputs from 3.3 to 30VDC, dual outputs ± 12 & ± 15 VDC
- ▶ Wide 4:1 DC input range 9 to 36 or 18 to 75VDC
- ▶ DIP16 metal case
- ▶ Output voltage trim $\pm 10\%$ (single output models)
- ▶ High efficiency up to 87%
- ▶ IEC/UL/cUL 62368-1 safety approvals (pending)
- ▶ Complies with EN55032 class A with no external components
- ▶ -40°C to $+85^{\circ}\text{C}$ operating temperature
- ▶ Full power to $+70^{\circ}\text{C}$
- ▶ MTBF >500 khrs (MIL-HDBK-217F, $+25^{\circ}\text{C}$ GB)
- ▶ 3 year warranty

Applications



Dimensions

23.8 x 13.7 x 10.3mm (0.94" x 0.54" x 0.41")

Models & ratings

Model number	Input voltage	Output voltage	Output current	Efficiency	Input current ⁽¹⁾		Maximum capacitive load
					No load	Full load	
JTR1024S3V3	9-36VDC	3.3VDC	2.7A	80%	10mA	464mA	2600 μ F
JTR1024S05		5.0VDC	2.0A	83%		502mA	1300 μ F
JTR1024S12		12.0VDC	0.833A	87%		479mA	560 μ F
JTR1024S15		15.0VDC	0.666A	87%		479mA	560 μ F
JTR1024S24		± 5.0 VDC	0.416A	87%		479mA	330 μ F
JTR1024D12		± 12.0 VDC	± 0.416 A	87%		478mA	± 390 μ F
JTR1024D15		± 15.0 VDC	± 0.333 A	87%		478mA	± 220 μ F

Continued on page 2

Notes:

1. Input currents measured at nominal input voltage.

2. Standard tube quantity: 20

Models & ratings

Model number	Input voltage	Output voltage	Output current	Efficiency	Input current ⁽¹⁾		Maximum capacitive load
					No load	Full load	
JTR1024S3V3	18-75VDC	3.3VDC	2.7A	80%	7mA	232mA	2600μF
JTR1024S05		5.0VDC	2.0A	83%		251mA	1300μF
JTR1024S12		12.0VDC	0.833A	87%		239mA	560μF
JTR1024S15		15.0VDC	0.666A	87%		239mA	560μF
JTR1024S24		±5.0VDC	0.416A	87%		239mA	330μF
JTR1024D12		±12.0VDC	±0.416A	87%		239mA	±390μF
JTR1024D15		±15.0VDC	±0.333A	87%		239mA	±220μF

Notes:

1. Input currents measured at nominal input voltage.

2. Standard tube quantity: 20

Input

Characteristic	Minimum	Typical	Maximum	Units	Notes & conditions
Input voltage range	9		36	VDC	24VDC nominal
	18		75		48VDC nominal
Input filter	Pi network				
Undervoltage lockout	ON at 8.8VDC, OFF at 7.0VDC				
	ON at 17.8VDC, OFF at 16.0VDC				
Input surge			50	VDC	24VDC models (for 1s)
			100		48VDC models (for 1s)

Output

Characteristic	Minimum	Typical	Maximum	Units	Notes & conditions
Output voltage	3.3		30	VDC	See models and ratings table
Initial set accuracy			±1.0	%	At full load
Output voltage balance			±1.0	%	For dual output with balanced loads
Minimum load					No minimum load required
Line regulation			±0.5	%	From minimum to maximum input at full load
Load regulation			±1.0	%	From 0 to full load
Cross regulation		3	±5.0	%	On dual output models when one load is varied between 25% and 100% and other is fixed at 100%
Transient response			5	% deviation	Recovery within 1% in less than 250μs for a 25% load change.
Ripple & noise			60	mV pk-pk	3V3, 5V output models: 20MHz bandwidth. Measured using 1μF ceramic capacitor and 10μF electrolytic capacitor
			80		Other models: 20MHz bandwidth. Measured using 1μF ceramic capacitor and 10μF electrolytic capacitor
Overload protection		160		%	
Short circuit protection	Continuous trip & restart (hiccup mode), with auto recovery				
Maximum capacitive load	See models and ratings table				
Temperature coefficient			0.02	%/°C	

General

Characteristic	Minimum	Typical	Maximum	Units	Notes & conditions
Efficiency		87		%	See models and ratings table
Isolation: input to output	1500			VDC	60s functional
Isolation resistance	10 ⁹			Ω	At 500VDC
Isolation capacitance		1500		pF	
Switching frequency		370		kHz	
Power density		2.92 (48.0)		W/cm ² (W/in ²)	
Mean time between failure	500			khrs	MIL-HDBK-217F, +25°C GB
Case material	Black coated copper with non conductive plastic base UL94V-0 rated				
Potting material	Epoxy UL94V-0				
Pin material	Brass, solder coated				
Solder profile	260°C max. 1.5mm from case 10s maximum.				
Water wash	Use deionized water, do not soak. Dry thoroughly.				
Weight		10 (0.0022)		g (lb)	

Environmental

Characteristic	Minimum	Typical	Maximum	Units	Notes & conditions
Operating temperature	-40		+85	°C	See derating curve
Storage temperature	-55		+125	°C	
Case temperature			+105	°C	
Cooling	Natural cooled				
Operating humidity			95	%	RH, non condensing

Safety approvals

Safety agency	Standard	Notes & conditions
UL	UL/cUL62368-1	Information technology
CE	Meets all applicable directives	
UKCA	Meets all applicable legislation	

Emissions - EMC

Phenomenon	Standard	Test level	Notes & conditions
Conducted	EN55032	Class A	No external components required, see application notes for Class B.
Radiated	EN55032	Class A	

Immunity - EMC

Phenomenon	Standard	Test level	Criteria	Notes & conditions
	EN61000-4-2	±6kV	A	Contact
		±8kV		Air
Radiated immunity	EN61000-4-3	20V/m	A	
EFT/Burst	EN61000-4-4	±2kV	A	With external capacitor and TVS, see applications notes.
Surge	EN61000-4-5	±1kV	A	With external capacitor and TVS, see applications notes.
Conducted immunity	EN61000-4-6	10Vrms	A	
Magnetic fields	EN61000-4-8	100A/m	A	

Application notes

Derating curve

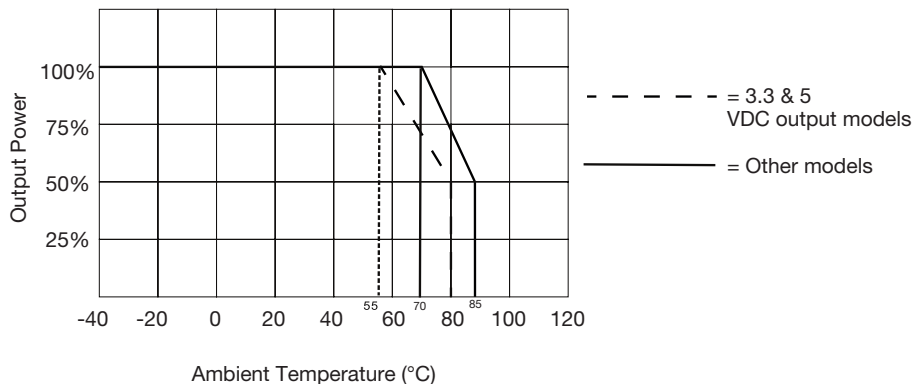

Input filter to meet Class B conducted emissions

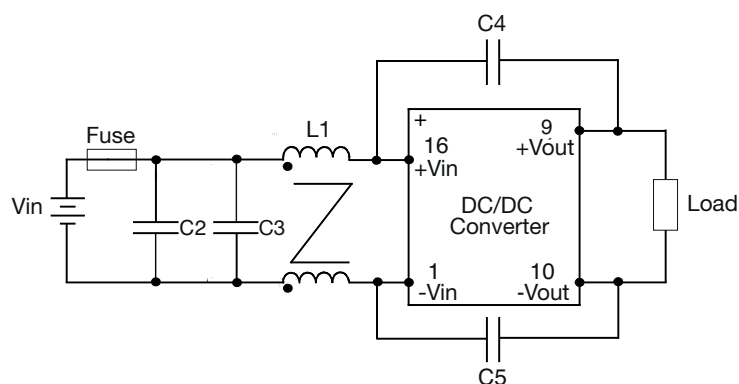

EFT & surge

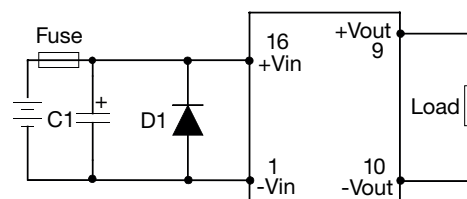

Model	C1	D1	C2	C3	L1	C4	C5
JTR1024	Nippon-chemi-con KY series 220 μ F, 100V	TVS, 58V, 3kW	1206, 10 μ F/50V	Not fitted	LFD648075 52 μ H-3.14A	1206, 100pF/2kV	1206, 100pF/2kV
JTR1048	Nippon-chemi-con KY series 220 μ F, 100V	TVS, 120V, 3kW	1206, 2.2 μ F/100V	1206, 2.2 μ F / 100V	LFD648075 175 μ H-1.76A	1206, 100pF/2kV	1206, 100pF/2kV

Select fuse rating based on application input current.

Mechanical details

Output trim

Output can be externally trimmed by using the method below. (single output models only).

Rtrim-down

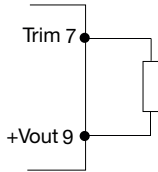

Trim down resistor values (Rd)

Model	1%	2%	3%	4%	5%	6%	7%	8%	9%	10%
3V3DC	194.3kΩ	116.4kΩ	80.2kΩ	59kΩ	45.6kΩ	36kΩ	29kΩ	23.5kΩ	19.2kΩ	15.6kΩ
5VDC	217.2kΩ	101.8kΩ	63.3kΩ	44kΩ	32.6kΩ	24.9kΩ	19.4kΩ	15.2kΩ	12kΩ	9.5kΩ
12VDC	1812kΩ	759kΩ	458.3kΩ	315.8kΩ	232.8kΩ	178.3kΩ	140kΩ	111.3kΩ	89.2kΩ	71.7kΩ
15VDC	1765kΩ	738.5kΩ	445kΩ	306kΩ	225kΩ	172kΩ	134.5kΩ	106.6kΩ	85kΩ	67.9kΩ
24VDC	1191kΩ	532kΩ	325.2kΩ	224kΩ	164kΩ	124.3kΩ	96kΩ	75kΩ	58.6kΩ	45.5kΩ

Rtrim-up

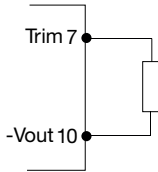

Trim up resistor values (Ru)

Model	1%	2%	3%	4%	5%	6%	7%	8%	9%	10%
3V3DC	1178kΩ	237.3kΩ	127.2kΩ	84.6kΩ	62kΩ	47.9kΩ	38.3kΩ	31.4kΩ	26.1kΩ	22kΩ
5VDC	442.3kΩ	217.8kΩ	142.3kΩ	105.5kΩ	83kΩ	68kΩ	57.3kΩ	49.3kΩ	43.1kΩ	38.1kΩ
12VDC	923.4kΩ	479.9kΩ	312.4kΩ	224.7kΩ	170.7kΩ	134.1kΩ	107.8kΩ	87.8kΩ	72.1kΩ	59.6kΩ
15VDC	957.2kΩ	496.7kΩ	324kΩ	233.5kΩ	177.8kΩ	140.1kΩ	112.9kΩ	92.3kΩ	76.1kΩ	63.2kΩ
24VDC	726.5kΩ	353.5kΩ	222.4kΩ	155.5kΩ	114.8kΩ	87.6kΩ	68kΩ	53.3kΩ	41.8kΩ	32.6kΩ

Mechanical details

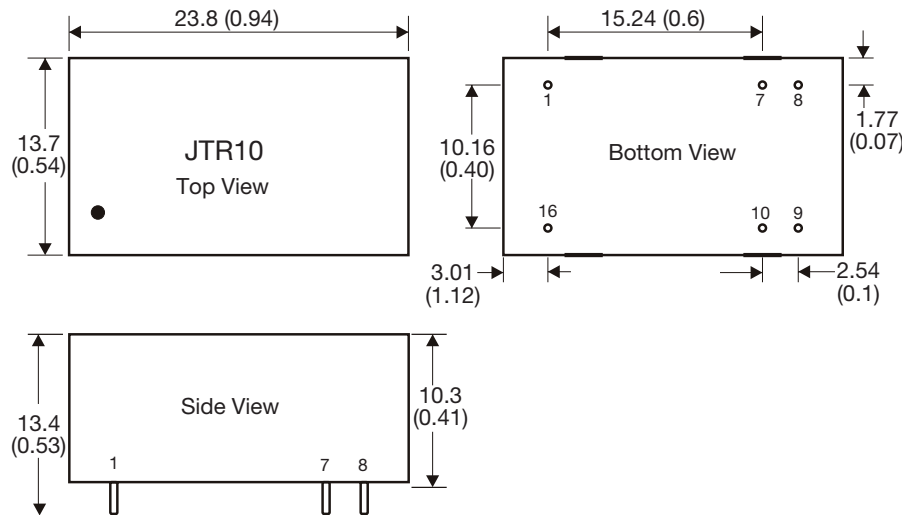

Pin connections		
Pin	Single	Dual
1	-Vin	-Vin
7	Trim	No Connection
8	No Connection	Common
9	+Vout	+Vout
10	-Vout	-Vout
16	+Vin	+Vin

Notes:

- All dimensions are in mm (inches)
- Weight: 10.0 (0.0022) g (lb) approx.
- Tolerances x.x ±0.25 (x.xx ±0.01), x.xx ±0.13 (x.xxx±0.005)
- Pin diameter: 0.5 (0.02)
- Pin tolerance: ±0.05 (±0.002)

Specifications subject to change without notice.