

15W Baseplate cooled

DC-DC converters

The MTC15 is a COTS DC-DC converter developed specifically for the defense and avionics market. This product has a full military specification while offering the short lead-times and cost benefits of a COTS component.

The MTC15 uses a forward converter design switching at 450kHz giving excellent size, efficiency and EMC performance. The input range is designed to provide short term operation over 10V to 50VDC to enable the converter to work at full power through the dips and surges commonly seen in vehicle and aircraft applications. A soft start circuit provides well controlled outputs with no overshoot.

Comprehensive control functions such as voltage trim, remote sense, inhibit and frequency synchronization to an external source are standard features. When used in conjunction with the MTF input filter module the MTC15 complies to MIL-STD-461; MIL-STD-1275; MIL-STD-704.



Features

- ▶ Regulated single outputs 3.3V to 28VDC
- ▶ Regulated dual outputs $\pm 12V$ & $\pm 15VDC$
- ▶ 10V to 50VDC input range
- ▶ Baseplate cooled
- ▶ Designed for vetronic & avionic use
- ▶ MIL-STD-461 & DEF-STAN-59-411
- ▶ MIL-STD-1275 & DEF-STAN-61-5
- ▶ -40°C to +100°C operating temperature
- ▶ -55°C operation available on certain models
- ▶ 3 year warranty

Applications



COTS



Industrial



Technology

Dimensions

Single output:

40.0 x 26.0 x 9.7mm (1.57" x 1.02" x 0.38")

Dual output:

40.0 x 26.0 x 12.7mm (1.57" x 1.02" x 0.5")

Models & ratings

| Model number ⁽²⁾ | Output power | Output voltage | | | Output current | Input current ⁽⁵⁾ | | Efficiency |
|-------------------------------|--------------------|----------------|------------------------|------------------------|------------------|------------------------------|-----------|------------|
| | | Nominal | Minimum ⁽¹⁾ | Maximum ⁽¹⁾ | | No load | Full load | |
| MTC1528S3V3 | 10W | 3.3VDC | 3.3VDC | 4.0VDC | 3.03A | 0.04A | 0.46A | 77% |
| MTC1528S3V3-LT ⁽³⁾ | | 3.3VDC | 3.3VDC | 4.0VDC | 3.03A | 0.04A | 0.46A | 77% |
| MTC1528S05 | | 5.0VDC | 4.0VDC | 6.0VDC | 2.40A | 0.05A | 0.53A | 81% |
| MTC1528S05-LT ⁽³⁾ | 12W | 5.0VDC | 4.0VDC | 6.0VDC | 2.40A | 0.05A | 0.53A | 81% |
| MTC1528S12 | | 12.0VDC | 9.0VDC | 13.8VDC | 1.25A | 0.04A | 0.67A | 80% |
| MTC1528S15 | | 15.0VDC | 11.0VDC | 17.0VDC | 1.00A | 0.05A | 0.67A | 80% |
| MTC1528S28 | 15W | 28.0VDC | 20.0VDC | 30.0VDC | 0.54A | 0.03A | 0.69A | 78% |
| MTC1528D12 | 15W ⁽⁵⁾ | $\pm 12VDC$ | | | $\pm 1.0A^{(5)}$ | 0.03A | 0.68A | 80% |
| MTC1528D12-LT ⁽³⁾ | 15W ⁽⁵⁾ | $\pm 12VDC$ | | | $\pm 1.0A^{(5)}$ | 0.03A | 0.68A | 80% |
| MTC1528D15 | 15W ⁽⁵⁾ | $\pm 15VDC$ | | | $\pm 0.8A^{(5)}$ | 0.03A | 0.68A | 80% |

Notes:

1. Indicates maximum and minimum voltage adjustment (maximum includes Remote Sense adjustment).
2. For additional ESS screening, add the suffix '-ESS' to the model number e.g. MTC1528S05-ESS.
3. Suffix '-LT' indicates -55°C extended operating range.
4. Typical with $V_{in} = 28VDC$.
5. Max power 15W must not be exceeded.

Input

| Characteristic | Minimum | Typical | Maximum | Units | Notes & conditions |
|----------------------------------|------------------------------|---------|---------|-------|--------------------|
| Input voltage range | 15.5 | | 40 | VDC | |
| Transient input range | | 10 | | VDC | 10s |
| | | 50 | | | 1s |
| Turn on | | <15.5 | | VDC | |
| Turn off | | <10 | | VDC | |
| Input reverse voltage protection | None | | | | |
| Max. input current | See models and ratings table | | | | |

Output

| Characteristic | Minimum | Typical | Maximum | Units | Notes & conditions |
|----------------------------|------------------------------|---------|---------|----------|--|
| Output voltage | See models and ratings table | | | | |
| Output voltage trim | See models and ratings table | | | | |
| Minimum load | No minimum load required | | | | |
| Line regulation | | ±1 | | % | Vout nominal (15.5-40.0Vin) |
| Load regulation | | ±1 | | % | Vout nominal |
| Cross regulation | | ±3 | | % | With 150mA min load (dual output only) |
| Output set tolerance | | ±100 | | mV | Or ±2% whichever is greater |
| Ripple and noise | | | 75 | mV pk-pk | ≤5Vout, 20MHz bandwidth |
| | | | 1 | % pk-pk | >5Vout, 20MHz bandwidth |
| Overvoltage protection | 110 | | 120 | % | |
| Overcurrent protection | 105 | | 150 | % | At nominal input voltage |
| Short circuit protection | Trip and restart | | | | |
| Overtemperature protection | 102 | | 107 | °C | 2°C to 5°C hysteresis |
| Remote sense | | 0.5 | | V | Single output only |
| Load step output transient | | <±3 | | % | Vout nominal (25-75% load) |
| Line step recovery | | 500 | | µs | Within 1% of nominal value |
| Start up time | | <100 | | ms | |
| Maximum capacitive load | | | 300 | µF | Iout maximum start up within 100ms |

General

| Characteristic | Minimum | Typical | Maximum | Units | Notes & conditions |
|----------------------------|---|-------------|---------|--|----------------------------|
| Efficiency | See models & ratings table | | | | |
| Isolation: input to output | | 1500 | | VDC | |
| Isolation: input to case | | 1000 | | VDC | |
| Isolation: output to case | | 500 | | VDC | |
| Switching frequency | | 450 | | kHz | |
| Frequency synchronization | 400 | | 500 | kHz | |
| Inhibit | Off = TTL Low or short circuit, On = TTL High or open circuit | | | | |
| Power density | | 1.48 (24.4) | | W/cm ³ (W/in ³) | |
| Mean time between failure | | 890 | | kHrs | MIL-HDBK-217F at +40°C, GF |

Environmental

| Characteristic | Minimum | Typical | Maximum | Units | Notes & conditions |
|----------------------|--------------------------------------|-----------------|---------|-------------|--|
| Operating base plate | -40 | | +100 | °C | -55°C to +100°C extended range '-LT' |
| Storage temperature | -55 | | +125 | °C | |
| Operating humidity | | | 95 | %RH | 240hrs MIL-STD-810D Method 507.2 |
| Cooling | Conduction cooling through baseplate | | | | |
| Operating altitude | | 21,336 (70,000) | | metres (ft) | |
| Shock | | 100 | | g | MIL-STD-810D Method 516.3 |
| Vibration | 5 | | 500 | Hz | MIL-STD-810D Method 514.3 |
| Bump | | 2000 | | Bumps | In each axis 40g MIL-STD-810D Method 516.3 |
| Salt atmosphere | | 48 | | Hrs | MIL-STD-810E Method 509.3 |

All standard products are stress-screened and electrically tested over the operating temperature range. See notes for option details.

EMC: emissions

| Phenomenon | Standard | Test level | Notes & conditions |
|------------|-------------------------------------|----------------------|--|
| Conducted | MIL-STD-461E/F/G DEF-STAN 59-411 | CE102 DCE01/DCE02 | MTF50 filter module required to meet these standards |

EMC: Immunity

| Phenomenon | Standard | Test level | Criteria | Notes & conditions |
|--------------------------|--|------------|----------|--------------------|
| ESD immunity | MIL-STD-704 A, MIL-STD-704 B-F, MIL-STD-1275A/B/C/D/E (MTF50 filter module required to meet these standards) | | | |
| Conducted susceptibility | MIL-STD-461E/F/G CS101, CS114,CS115,CS116, DEF-STAN 61-5 part 6 issue 5 (MTF50 filter module required to meet these standards) | | | |

Safety approvals

| Safety agency | Standard | Test level | Notes & conditions |
|---------------|----------------------------------|------------|--------------------|
| CE | Meets all applicable directives | | |
| UKCA | Meets all applicable legislation | | |

Application notes

Efficiency curves

MTC1528S05

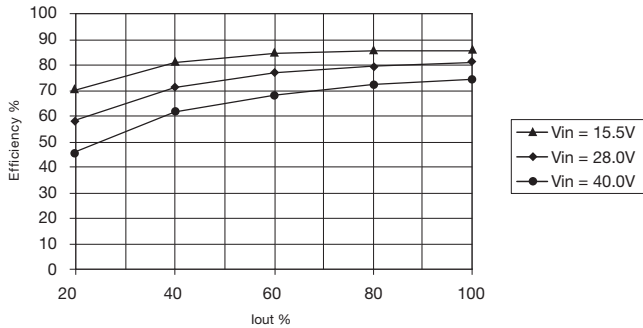

MTC1528S28

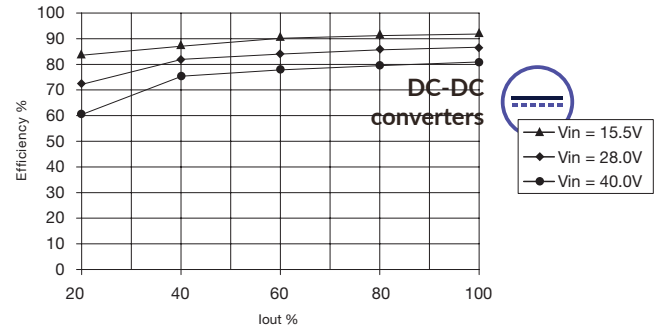

MTC1528D15

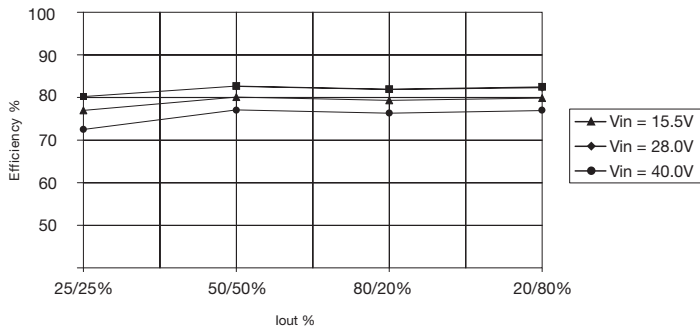

Mechanical details

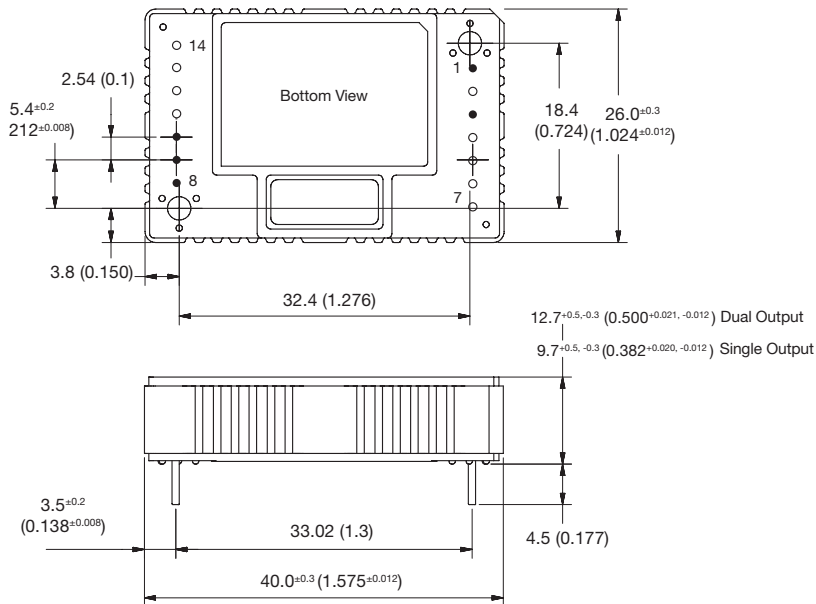

| Pin connections | | |
|-----------------|-----------------|-----------------|
| Pin | Single output | Dual output |
| 1 | No Pin | No Pin |
| 2 | Case | Case |
| 3 | No Pin | No Pin |
| 4 | -Vin | -Vin |
| 5 | Synchronization | Synchronization |
| 6 | +Vin | +Vin |
| 7 | Inhibit | Inhibit |
| 8 | No Pin | No Pin |
| 9 | No Pin | No Pin |
| 10 | No Pin | -Vout |
| 11 | + Sense | No Pin |
| 12 | -Vout | COM |
| 13 | Adjust | No Pin |
| 14 | +Vout | +Vout |

Notes:

- Dimensions are in mm (inches)
- Tolerance: $\pm 0.5\text{mm}$ ($\pm 0.02''$) except where indicated.
- Weight: 20g (0.04lb)

4. Materials & Finish:
- Pin: Diameter: 0.8 (0.032)
Material: Cu Zn30 2.5 μm Ni
Finish: 0.2-0.5 μm AU (HV 170-200)
 - Case: Material: Aluminium (Al Mg Si 0.5)
Finish: Chromated
 - Nameplate: Non-conductive plastic

Specifications subject to change without notice.