

MTH100 Series



- Designed for Extended Hold Up Applications
- 80% Less Hold Up Capacitance Required
- Reduces System Size and Weight
- 10 A Output Current
- Wide Input Range
- User Programmable
- 3 Year Warranty

Specification

Input

Input Voltage	• 10-40 VDC (50VDC for 1 s)
Input Current	• 10.05 A max at full load
Additional Input Charging Current	• 1.5 A typical at 10 V input, during hold up capacitor charging, 2.5 A max
No Load Current	• <50 mA
Power Fail Voltage Threshold (DCFP)	• V_{fail} set by resistor R1, see application notes
Input Reverse Voltage Protection	• Required, see application notes

Output

Output Current	• 10 A max
Output Power	• 100 W max
Voltage Drop	• <130 mV at 10 A max
Output Voltage	• See table
Changeover Capacitor (C2)	• 150 μ F min - 470 μ F max (\pm 20%), see application notes
Hold Up Time	• See application notes

Charger Output

Hold Up Capacitor (C1)	• 1000 μ F min, see application notes
Hold Up Capacitor Charge Time	• See application notes
Set Accuracy	• \pm 2%
Charge Output Voltage (Vcap)	• 35 V -0/+4% CVP pin not connected 45 V -0/+4% CVP pin connected to ground
Overvoltage Protection	• 49 V \pm 1 V
Overload Protection	• No damage for overload or short circuit. If output voltage <30 V after 10 s the charger will shut down and re-start after a further 10 s
Overtemperature Protection	• 102-107 $^{\circ}$ C with 5 $^{\circ}$ C typical hysteresis
Charge/Discharge Detect Signal (CDD)	• Open collector output, 100 V, 100 mA max Low at 90% Vcap, High at 30% Vcap Tolerance: \pm 3%
Power Fail Detect (DCFD)	• Open collector output, 100 V, 100 mA max Low: V_{in} > fail voltage threshold High: V_{in} < fail voltage threshold Tolerance: \pm 3%

General

Efficiency	• 98% typical
Series Resistance Isolation	• 0.013 Ω • 1000 VDC Input to Case 1000 VDC Output to Case
Charger Switching Frequency	• 400 kHz typical
MTBF	• 1.7 Mhrs to MIL-HDBK-217F at 40 $^{\circ}$ C, GF

Environmental

Operating Temperature	• -40 $^{\circ}$ C to +100 $^{\circ}$ C case Extended Temperature Range: (option -LT) -55 $^{\circ}$ C start up
Storage Temperature	• -50 $^{\circ}$ C to +125 $^{\circ}$ C
Operating Altitude	• Tested to 70000 ft (21336 m)
Shock	• 100 g MIL-STD-810D Method 516.3
Vibration	• 10 to 2000 Hz MIL-STD-810D Method 514.3
Bump	• 2000 Bumps in each axis 40 g MIL-STD-810D Method 516.3
Salt Atmosphere	• 48 hours MIL-STD-810E Method 509.1

EMC

Conducted Emissions	• EN55022 Conducted Level B. MIL-STD-461E/F/G, CE101 & CE102
Immunity	• MIL-STD-1275A/B/C/D/E
Conducted Susceptibility	• MIL-STD-461E/F/G, CS101, CS114, CS115 & CS116

Safety

Safety Approvals	• CE & UKCA meets all applicable directives & legislation.
------------------	--

EMC standards are met when used in conjunction with the MTF or DSF filter modules or other external components, consult longform datasheet.

Models & Ratings

Output Voltage	Input Voltage	Efficiency	Model Number
$V_{in} - (I_{out} \times 0.013)^{(1)}$	10 - 40 VDC	98 %	MTH100
$V_{cap} - 0.8V^{(2)}$			

Notes

1. During normal operation.
2. During hold-up time.

Mechanical Details

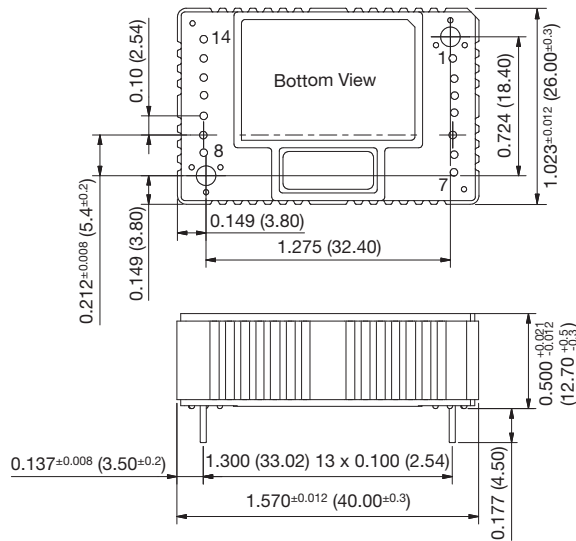

Pin	Function	Pin	Function
1	Not fitted	8	Not fitted
2	Case	9	+Vout
3	Not fitted	10	+Vout
4	-Vin	11	Hold-up capacitor voltage, Vcap
5	Input DC fail programming (DCFP)	12	Charge voltage programming (CVP)
6	+Vin	13	Input DC fail detect (DCFD)
7	+Vin	14	Charge/discharge detect (CDD)

Notes

1. Dimensions are in inches (mm)
2. Tolerance: ±0.02 (±0.5) unless otherwise stated
3. Weight: 0.06 lb (25 g)
4. Materials & Finish:
 - Pin - Diameter: 0.032 (0.8), Material: Cu Zn30 2.5 µm Ni
 - Finish: 0.2-0.5 µm AU (HV 170-200)
 - Mounting Hole - Diameter: 0.102 (2.6)
 - Case - Material: Aluminium (Al Mg Si 0.5), Finish: Chromated
 - Nameplate - Non-conductive plastic

Application Notes

Maximum charge time at Vin = 10 V				
C1 (µF)	Vcap (V)	Time (s)		
		Typical	Max	
10,000	45	1.2	1.5	
10,000	35	0.8	1.0	
30,000	45	3.4	4.0	
30,000	35	2.0	2.4	
50,000	45	5.5	6.0	
50,000	35	3.2	3.8	

$$R1 = \left(\frac{40.67}{V_{fail} - 9.785} - 3.92 \right) \times 10^3$$

$$C1 = \left(\frac{2 \times P_{out} \times t_{hold-up}}{V_{cap}^2 - V_{min}^2} \right) \times 1.1$$

$$C2 = \frac{P_{out} \times 400 \times 10^{-6}}{V_{fail}^2 - V_{min}^2}$$

- R1: Resistor setting the input voltage fail threshold (DCFP)
- V_{fail}: Required fail voltage
- C1: Hold up capacitor (minimum value including tolerance)
- t_{hold-up}: Hold up time required
- V_{cap}: C1 charge voltage
- V_{min}: Minimum DC/DC input voltage (≥10 VDC)
- P_{out}: Output power from MTH100
- C2: Changeover capacitor

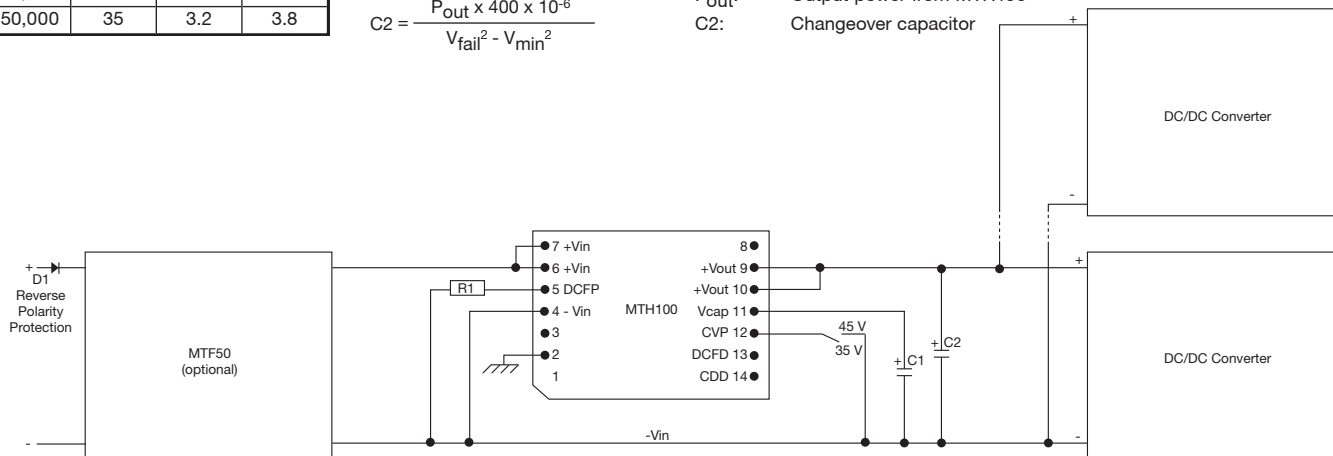

Notes

1. C1 has a minimum value of 1000 µF, this enables an open circuit or missing component to be detected. There is no maximum limit other than extended charge time.
2. MTH100 charges the Hold-up capacitor C1 to 45V max when charge voltage programming (CVP) pin is connected or 35V when not connected.
3. Input DC fail programming (DCFP) sets the power fail voltage threshold using resistor R1. See formula for the value required.
4. Input DC fail detect (DCFD) is an open collector circuit which changes state when the input voltage falls below the set threshold.
5. Charge/discharge detect (CDD) is an open collector circuit which goes low when C1 is charged to 90% of Vcap or high when C1 discharges down to 30% of Vcap.
6. See longform datasheet for detailed application information.