

100W Baseplate cooled

DC-DC converters

The ICH100 series offers a compact 100W DC-DC converter solution in an industry standard ½ brick package, with integral baseplate for conduction cooling.

Available in 2:1 input ranges, covering 18 to 36VDC & 36 to 75VDC, and 4:1 input ranges, 9 to 36VDC & 18 to 75VDC.

Standard features are: ±10% output voltage trim, remote sense, remote On/Off, a wide operating temperature range and includes protection for over current, over temperature and over voltage.



Features

- ▶ Regulated single outputs 3.3 to 24VDC
- ▶ 2:1 & 4:1 input ranges
- ▶ Baseplate cooled ½ brick package
- ▶ 1.5kVDC isolation
- ▶ Output trim ±10%
- ▶ Remote sense
- ▶ Remote On/Off
- ▶ Continuous short circuit protection
- ▶ -40°C to +100°C operating temperature
- ▶ 3 year warranty

Applications

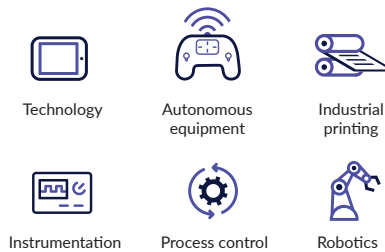

Dimensions

61.0 x 57.9 x 12.7mm (2.40" x 2.28" x 0.5")
½ brick package

Models & ratings

Model number ^(2,5)	Input voltage	Output voltage	Output current	Input current ⁽⁴⁾		Efficiency	
				No load	Full load		
ICH10024S3V3	18-36VDC (24V nominal)	3.3VDC	20.00A	50mA	3480mA	79%	
ICH10024S05		5.0VDC	20.00A		5020mA	83%	
ICH10024S12		12.0VDC	8.30A		4880mA	85%	
ICH10024S15		15.0VDC	6.70A		4925mA	85%	
ICH10024S24		24.0VDC	4.17A		4905mA	85%	
ICH10048S3V3	36-75VDC (48V nominal)	3.3VDC	20.00A	50mA	1720mA	80%	
ICH10048S05		5.0VDC	20.00A		2480mA	84%	
ICH10048S12		12.0VDC	8.30A		2442mA	85%	
ICH10048S15		15.0VDC	6.70A		2463mA	85%	
ICH10048S24		24.0VDC	4.17A		4.17A	2463mA	85%
						2463mA	85%

Continued on page 2

Notes:

1. Logic compatibility: Module On = Open circuit, Module Off = <0.8VDC
2. Add suffix 'N' to the model number to receive the unit with negative logic Remote On/Off.
3. Ripple & noise is measured with a 10µF tantalum capacitor and 0.1µF ceramic capacitor across output.
4. Input current specified at 24V for 18-36 & 9-36VDC and 48V for 36-75 & 18-75VDC models.
5. For dual output models available, contact sales.

Models & ratings

Model number ^(2,5)	Input voltage	Output voltage	Output current	Input current ⁽⁴⁾		Efficiency
				No load	Full load	
ICH10024WS3V3	9-36VDC (24V nominal)	3.3VDC	20.00A	35mA	3374mA	81%
ICH10024WS05		5.0VDC	20.00A		4990mA	83%
ICH10024WS12		12.0VDC	8.30A		4902mA	85%
ICH10024WS15		15.0VDC	6.70A		4817mA	86%
ICH10024WS24		24.0VDC	4.17A		4849mA	86%
ICH10048WS3V3	18-75VDC (48V nominal)	3.3VDC	20.00A	30mA	1708mA	80%
ICH10048WS05		5.0VDC	20.00A		2422mA	86%
ICH10048WS12		12.0VDC	8.30A		2408mA	86%
ICH10048WS15		15.0VDC	6.70A		2381mA	87%
ICH10048WS24		24.0VDC	4.17A		2367mA	88%

Notes:

- Logic compatibility: Module On = Open circuit, Module Off = <0.8VDC
- Add suffix 'N' to the model number to receive the unit with negative logic Remote On/Off.
- Ripple & noise is measured with a 10µF tantalum capacitor and 0.1µF ceramic capacitor across output.
- Input current specified at 24V for 18-36 & 9-36VDC and 48V for 36-75 & 18-75VDC models.
- For dual output models available, contact sales.

Input

Characteristic	Minimum	Typical	Maximum	Units	Notes & conditions
Input voltage range	See models and ratings table				
Input current (no load)	See models and ratings table				
Input reverse voltage protection	None				
Input filter	Pi network				
Undervoltage lockout	Power up: 8.8V, down: 8.0V				2:1 input, 12Vin
	Power up: 17.0V, down: 16.0V				2:1 input, 24Vin
	Power up: 34.0V, down: 32.5V				2:1 input, 48Vin
	Power up: 8.8V, down: 8.0V				4:1 input, 24Vin
	Power up: 17.0V, down: 16.0V				4:1 input, 48Vin

Output

Characteristic	Minimum	Typical	Maximum	Units	Notes & conditions
Output voltage trim		±10		%	See application notes
Initial set accuracy			±1.5	%	
Line regulation			±0.2	%	Measured from high line to low line
Load regulation			±0.2	%	Measured from 0-100% load
Transient response			5	%	Maximum deviation, recovery to within 1% in 500µs, 25% step load change
Ripple and noise			100	mV pk-pk	3.3 & 5VDC, 20MHz bandwidth, measured with a 10µF tantalum capacitor and 0.1µF ceramic capacitor across output
			150		12 & 15VDC, 20MHz bandwidth, measured with a 10µF tantalum capacitor and 0.1µF ceramic capacitor across output
			1	% pk-pk	24, 28 & 48VDC, 20MHz bandwidth
Overvoltage protection	115		140	%	
Short circuit protection	Trip & restart (hiccup mode) with auto recovery, ICH100W: current limit, auto recovery.				
Temperature coefficient		±0.03		%/°C	
Current Limit	110		160	%	Of nominal output
Remote On/Off	Logic compatibility: Module On = Open circuit, Module Off = <0.8VDC, add suffix 'N' to the model number to receive the unit with negative logic Remote On/Off.				
Thermal shutdown	Thermal shutdown when case temperature reaches +100°C, auto recovery when case temperature <+60°C ICH100W: Thermal shutdown when case temperature reaches 105°C, auto recovery when case temperature <+90°C				

General

Characteristic	Minimum	Typical	Maximum	Units	Notes & conditions
Efficiency	See models & ratings table				
Isolation: input to output	1500			VDC	
Isolation: input to case	1500			VDC	
Isolation: output to case	1500			VDC	
Isolation resistance	10 ⁷			Ω	
Isolation capacitance		100		pF	
Switching frequency		500		kHz	ICH100W
		250			
Power density		2.2 (36.6)		W/cm ³ (W/in ³)	
Mean time between failure		≥790		khrs	MIL-HDBK-217F, +25°C GB
Weight		95 (0.209)		g (lb)	

Environmental

Characteristic	Minimum	Typical	Maximum	Units	Notes & conditions
Operating base plate	-40		+100	°C	See derating curve
Storage temperature	-40		+105	°C	
Shock	30g pk, half sine wave for 18ms, 3 pulses per face, all 6 faces tested on all 3 axes				
Vibration	5-500 Hz at 3g, 10 mins per axis				

EMC: emissions

Phenomenon	Standard	Test level	Notes & conditions
Conducted	EN55032	A	With external components
Radiated	EN55032	A	With external components

EMC: immunity

Phenomenon	Standard	Test level	Criteria	Notes & conditions
ESD immunity	EN61000-4-2	2	A	
EFT/burst	EN61000-4-4	Level 1	A	
Surges	EN61000-4-5	Inst. Class 1	A	
Conducted	EN61000-4-6	3Vrms	A	
Magnetic field	EN61000-4-8	1A/m	A	

Safety approvals

Safety agency	Standard	Test level	Notes & conditions
UL	UL60950-1		
CE	Meets all applicable directives		
UKCA	Meets all applicable legislation		

Application notes

Thermal resistances vs air flow

Air flow rate	Typical Rca
Natural Convection 6.0m/min (20ft/min) (0.1m/s)	7.12°C/W
30.48 metres/min (100ft./min) (0.5m/s)	6.21°C/W
60.96 metres/min (200ft./min) (1.0m/s)	5.17°C/W
91.44 metres/min (300 ft./min) (1.5m/s)	4.29°C/W
121.92 metres/min (400 ft./min) (2.0m/s)	3.64°C/W
152.4 metres/min (500 ft./min) (2.5m/s)	2.96°C/W
182.88 metres/min (600 ft./min) (3.0m/s)	2.53°C/W
213.36 metres/min (700 ft./min) (3.5m/s)	2.37°C/W
243.84 metres/min (800 ft./min) (4.0m/s)	2.19°C/W

Temperature Rise:

$P_d \times R_{ca}$, Where $P_d = P_{in} - P_{out}$ or $P_{out} (1-\eta) / \eta$, Where $\eta =$ efficiency

External output trimming

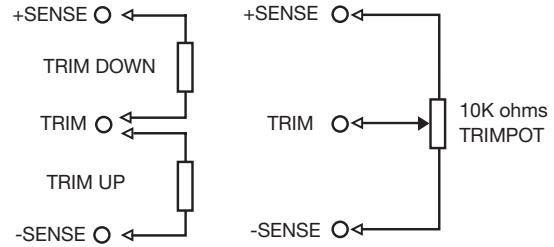

Output may be trimmed by $\pm 10\%$ ($\pm 5\%$ for dual output models) with a fixed resistor or an external trimpot as shown. Contact sales for details.

Logic table		
Logic State (Pin 2)	Positive Logic	Negative Logic (-N)
Logic Low Switch Closed	Module Off	Module On
Logic High Switch Open	Module On	Module Off

Maximum power dissipation vs ambient temperature and air flow (without heatsink)

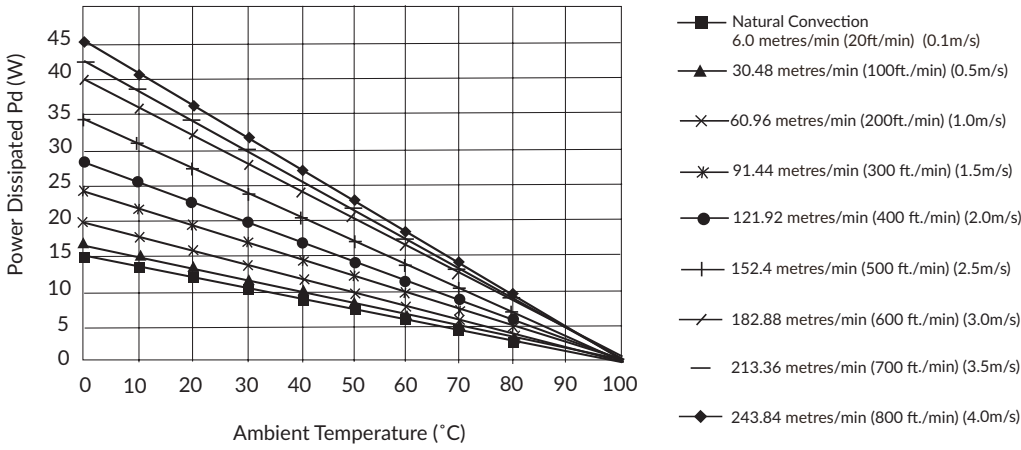

Forced Convection Power Derating without Heatsink

Output noise

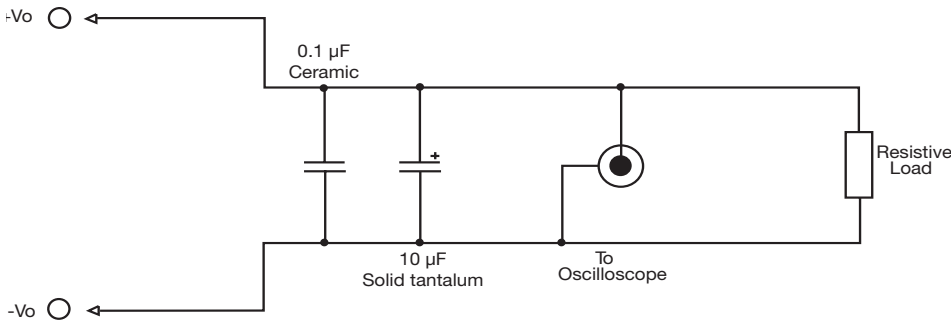

Output noise is measured with a 10 µF tantalum capacitor and 0.1 µF ceramic capacitor across output. Oscilloscope limited to 20 MHz bandwidth.

Mechanical details

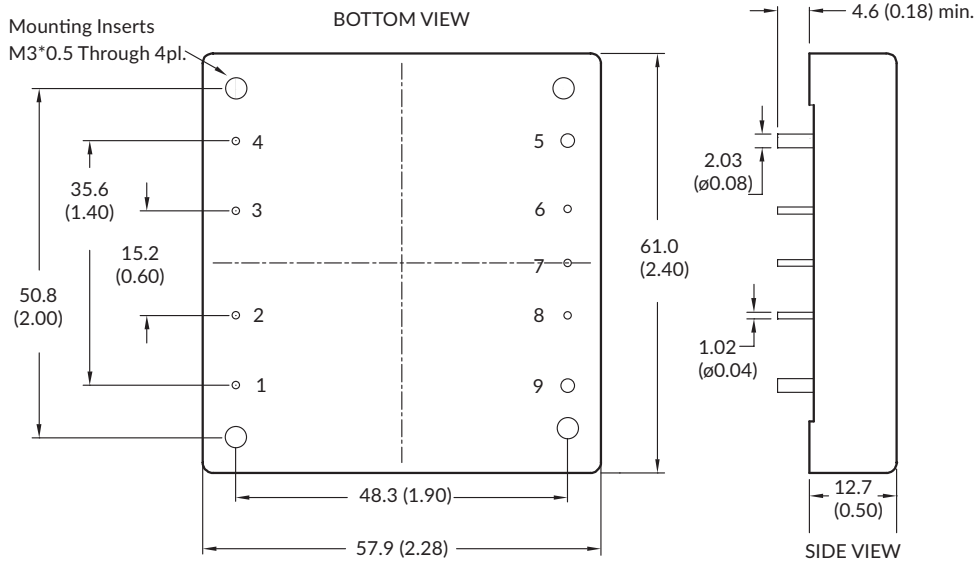

Pin connections	
Pin	Function
1	+Vin
2	On/Off
3	Case
4	-Vin
5	-Vout
6	-Sense
7	Trim
8	+Sense
9	+Vout

Notes:

1. Dimensions are in mm (inches)
2. Tolerances: x.xx (x.x) = ± 0.5 (± 0.02), x.xxx (x.xx) = ± 0.25 (± 0.01)
3. Case tolerance: ± 0.50 (± 0.02)
4. Pin diameter tolerance: ± 0.05 (± 0.002), ± 0.1 (± 0.004)
5. Case Material: Aluminium
6. Pin pitch tolerance: ± 0.25 (± 0.01)