

150 Watts

- Wide 4:1 input range
- Complies with EN50155 and EN45545-2
- Baseplate cooled
- Industry standard quarter brick
- Regulated single outputs
- Output trim $\pm 10\%$
- 2.2kVDC to 3.0kVDC isolation
- Efficiency to 92%
- Short circuit, overvoltage and overtemperature protection
- Remote on/off
- -40 °C to +105 °C operation
- 3 year warranty



Dimensions:

QSC150:
2.28 x 1.45 x 0.5" (57.9 x 36.8 x 12.7 mm)

The QSC150 series offers a compact 150W DC-DC converter solution in an industry standard quarter brick package. This series of modules enables effective construction of distributed power architectures. Utilizing the integral baseplate for conduction cooling gives the designer flexibility in system design. The QSC150 series features an industrial operating temperature range and includes protection for over current, over temperature and over voltage. Complies with railway standards EN50155 and EN45545-2.

Models & Ratings

Input Voltage	Output Voltage	Output Current	Input Current ⁽¹⁾		Ripple & noise pk-pk ⁽²⁾	Efficiency ⁽¹⁾	Max. capacitive load	Model Number ^(3,4)
			No Load	Full Load				
24V (9-36 V)	5 V	30.0 A	10 mA	18.1 A	100 mV	92.0%	30000 μ F	QSC15024S05
	12 V	12.5 A	10 mA	18.1 A	150 mV	92.0%	12500 μ F	QSC15024S12
	24 V	6.3 A	10 mA	18.3 A	280 mV	91.0%	6300 μ F	QSC15024S24
	28 V	5.4 A	10 mA	18.2 A	280 mV	91.5%	5400 μ F	QSC15024S28
	48 V	3.2 A	10 mA	18.1 A	480 mV	92.0%	1000 μ F	QSC15024S48
48V (18-75 V)	5 V	30.0 A	8 mA	9.1 A	100 mV	92.0%	30000 μ F	QSC15048S05
	12 V	12.5 A	8 mA	9.2 A	150 mV	91.0%	12500 μ F	QSC15048S12
	24 V	6.3 A	8 mA	9.2 A	280 mV	90.5%	6300 μ F	QSC15048S24
	28 V	5.4 A	8 mA	9.2 A	280 mV	90.5%	5400 μ F	QSC15048S28
	48 V	3.2 A	8 mA	9.1 A	480 mV	91.5%	1000 μ F	QSC15048S48

Notes

1. At nominal input voltage
2. Output ripple and noise measured with 10 μ F aluminum and 1 μ F ceramic capacitor across output for 48Vout and with 10 μ F tantalum and 1 μ F ceramic capacitor for others
3. For threaded baseplate fixing add suffix -T
4. For negative logic control add suffix -N e.g. QSC15048S12-NT

Input

Characteristic	Minimum	Typical	Maximum	Units	Notes & Conditions
Input Voltage Range	9		36	VDC	24 V nominal
	18		75		48 V nominal
Input Current				A	See Models and Ratings table
Input Surge			50/100	VDC for 100 ms	QSC15024 / QSC15048
Undervoltage Lockout		8.5/17.0		VDC	On: 24 V/48 V nominal
		8.0/16.0			Off: 24 V/48 V nominal
Lockout Hysteresis		0.6/0.9		VDC	24 V/48 V
Idle Current		5	10	mA	When output is remotely turned off
Inrush Current			0.1	A ² s	As per ETS300 132-2
Recommended Input Fuse		30/15		A	Time delay fuse - 24 V/48 V
Input Reflected Ripple Current		30		mA pk-pk	Through 12 µH inductor

Output

Characteristic	Minimum	Typical	Maximum	Units	Notes & Conditions
Output Voltage	3V3		48	VDC	See Models and Ratings table
Output Trim	±10			%	-20% for output models 3V3 and 5V
Initial Set Accuracy			±1	%	At full load and nominal input
Minimum Load	0			%	No minimum load required
Line Regulation			±0.2	%	From minimum to maximum input at full load
Load Regulation			±0.2	%	From 0% to full load
Transient Response			±5.0	%	Maximum deviation, recovering to less than 1% in 250 µs for 25% step load change.
Start Up Time		30		ms	
Output Voltage Rise Time		30		ms	
Ripple & Noise				mV pk-pk	See models and ratings table
Overload Protection	110	125	160	%	
Short Circuit Protection					Continuous hiccup mode, with auto recovery
Maximum Capacitive Load					See Models and Ratings table
Temperature Coefficient			0.02	%/°C	
Overvoltage Protection	115		140	%	
Remote On/Off	Output is on if remote on/off (pin 2) is open or high (3.5-75 VDC) Output turns off if remote on/off (pin 2) is low (<1.2 VDC max) Standard models have positive logic, optional negative logic available by adding suffix -N to the part number				

General

Characteristic	Minimum	Typical	Maximum	Units	Notes & Conditions
Efficiency		92		%	See Models and Ratings table
Isolation: Input to Output	2250/3000			VDC	60 s for 24V and 48V input nominal
Isolation: Input and output to Case	2250			VDC	60 s
Switching Frequency		285/300		kHz	48S12 model / All other models
Isolation Resistance	10 ⁹			Ω	
Isolation Capacitance		1500		pF	
Power Density			90.7	W/in ³	
Mean Time Between Failure		309/667		kHrs	S05/S48 output, MIL-HDBK-217F, +25°C GB
Water Wash	Use de-ionised water, dry thoroughly				
Case Material	Plastic DAP UL94V-0 rated, base aluminium				
Potting Material	Silicone UL94V-0 rated				
Pin Material	Copper pin, nickel plated finished with matte tin				
Solder Profile	Wave solder 260°C max for 5s max. Alternatively, 450°C max for 5s max using a 50W iron.				
Weight		0.15 (68.0)		lb (g)	

Environmental

Characteristic	Minimum	Typical	Maximum	Units	Notes & Conditions
Operating Base Plate Temperature	-40		+105	°C	
Storage Temperature	-55		+125	°C	
Thermal Protection		+110		°C	
Operating Altitude			3000	m	
Humidity			95	%RH	Non-condensing
Cooling					Base plate cooled

Safety Approvals

Agency	Standard	Notes & Conditions
UL	cUL60950-1, UL62368-1	ITE
EN	EN55015	Railway
CE	Meets all applicable directives	
UKCA	Meets all applicable legislation	

EMC: Emissions

Phenomenon	Standard	Test Level	Notes & Conditions
Conducted	EN55032	Class A	See Application Notes
Radiated	EN55032	Class A	

EMC: Immunity

Phenomenon	Standard	Test Level	Criteria	Notes & Conditions
ESD Immunity	EN61000-4-2	±6 kV/±8 kV	A	Contact Discharge/Air Discharge
Radiated Immunity	EN61000-4-3	20 V/m	A	
EFT/Burst	EN61000-4-4	1 kV	A	With 470 µF/100 V electrolytic on input
Surge	EN61000-4-5	2 kV	A	External TVS, SMCJ78A and 470 µF/100 V on input
Conducted Immunity	EN61000-4-6	10 V rms	A	
Magnetic Fields	EN61000-4-8	3 A/m	A	

Mechanical Details

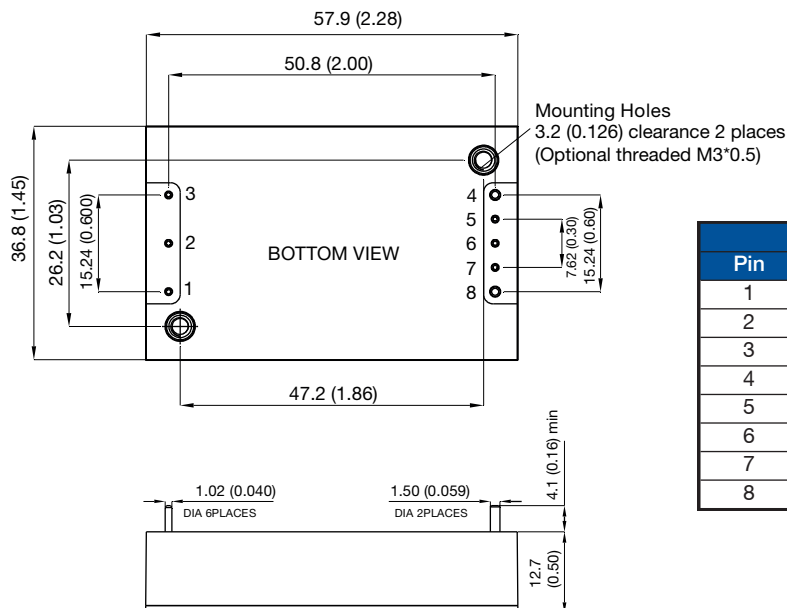

Pin Connections	
Pin	Function
1	+Vin
2	Remote On/Off
3	-Vin
4	-Vout
5	-Sense
6	Trim
7	+Sense
8	+Vout

Notes

- All dimensions are in inches (mm)
- Weight: 0.15 lbs (68 g) approx.

- Tolerance: x.xx = ±0.02 (x.x = ±0.5)
x.xxx = ±0.01 (x.xx = ±0.25)

Application Notes

Input Fusing and Safety Considerations

The QSC150 series converters have no internal fuse. In order to achieve maximum safety and system protection, always use an input line fuse. We recommended a 30 A time delay fuse for nominal 24 V and 15 A time delay fuse for nominal 48 V. It is recommended that the circuit has a transient voltage suppressor diode (TVS) across the input terminals to protect the unit against surge or spike voltages and input reverse voltage (as shown). A suitable part would be SMCJ78A.

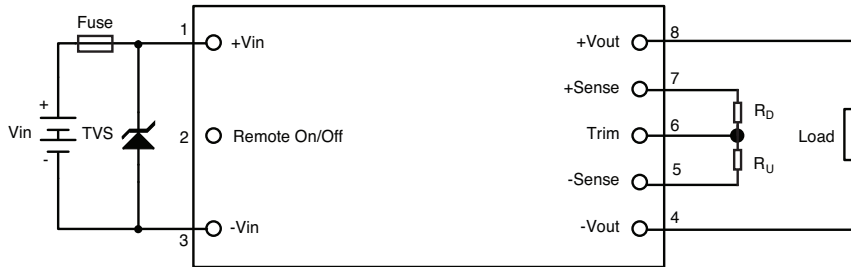

Output Voltage Adjustment

The Trim input permits the user to adjust the output voltage up or down 10%. This is accomplished by connecting an external resistor between the Trim pin and either the +Sense pin or the -Sense pin.

To Trim Down

Connecting an external resistor (R_D) between the Trim pin and the Vout (+) (or +Sense) pin decreases the output voltage. The following table can be used to determine the required external resistor (R_D) value to obtain a percentage output voltage change of $\Delta\%$.

Trim Down %	RD (k Ω)				
	5 V	12 V	24 V	28 V	48 V
1%	110.400	660.30	1671.00	1984.00	3106.00
2%	52.380	300.10	775.80	905.50	1400.00
3%	33.050	180.00	477.20	545.80	831.50
4%	23.380	120.00	327.90	365.90	547.10
5%	17.580	83.99	238.30	258.00	376.50
6%	13.710	59.97	178.60	186.00	262.80
7%	10.950	42.82	136.00	134.60	181.50
8%	8.880	29.95	104.00	96.10	120.60
9%	7.269	19.95	79.07	66.12	73.17
10%	5.980	11.94	59.17	42.14	32.25

Remote Sense

The module will automatically trim the output voltage via the sense pins to the default values either locally or at the load. If not required, the sense pins should be connected locally.

To Trim Up

Connecting an external resistor (R_U) between the Trim pin and the Vout (-) (or -Sense) pin increases the output voltage. The following table can be used to determine the required external resistor (R_U) value to obtain a percentage output voltage change of $\Delta\%$.

Trim Up %	RU (k Ω)				
	5 V	12 V	24 V	28 V	48 V
1%	112.700	153.20	165.70	168.30	148.60
2%	54.700	74.30	79.36	81.16	71.81
3%	35.370	47.99	50.58	52.12	46.21
4%	25.700	34.83	36.19	37.60	33.40
5%	19.900	26.94	27.56	28.86	25.72
6%	16.030	21.68	21.80	23.08	20.60
7%	13.270	17.92	17.69	18.93	16.94
8%	11.200	15.10	14.61	15.82	14.20
9%	9.589	12.91	12.21	13.40	12.07
10%	8.300	11.15	10.29	11.47	10.36

Thermal Resistance Information

Airflow Derating Graph - Without Heatsink

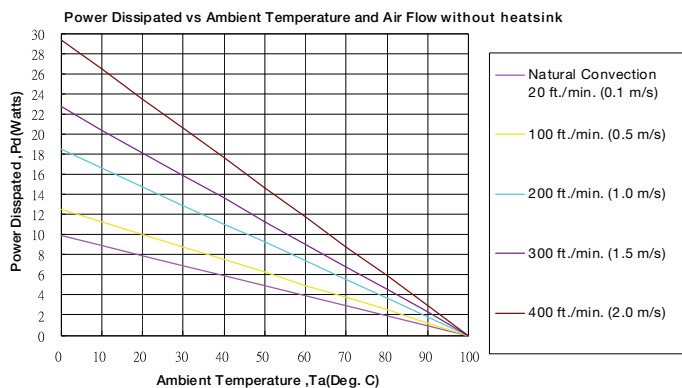

Air Flow Rate	Typical Rca
Natural Convection 20 ft/min (0.1 m/s)	10.1 °C/W
100 ft/min (0.5 m/s)	8.0 °C/W
200 ft/min (1.0 m/s)	5.4 °C/W
300 ft/min (1.5 m/s)	4.4 °C/W
400 ft/min (2.0 m/s)	3.4 °C/W

Example (Without Heatsink)

To determine the minimum airflow necessary for a QS15048S12 operating at an input voltage of 48 V, an output current of 12.5 A, and a maximum ambient temperature of 40°C:

Determine Power dissipation (Pd): $P_d = P_i - P_o = P_o(1-\eta)/\eta$,

$P_d = 12\text{ V} \times 12.5\text{ A} \times (1-0.9)/0.9 = 16.67\text{ Watts}$

Where P_i = Input power, P_o = Output Power and η = Efficiency

Determine airflow from airflow derating graph using data points for $P_d=16.67\text{ W}$ and $T_a = 40\text{ }^\circ\text{C}$

Minimum airflow= 400 ft./min.

To check that the maximum case temp of 105°C is not exceeded:

Maximum temperature rise is

$\Delta T = P_d \times R_{ca} = 16.67 \times 3.4 = 56.65^\circ\text{C}$.

Maximum case temperature is

$T_c = T_a + \Delta T = 96.68^\circ\text{C} < 105^\circ\text{C}$.

Where: R_{ca} is the thermal resistance from case to ambient environment. T_a is ambient temperature and T_c is case temperature.

Conducted Emissions

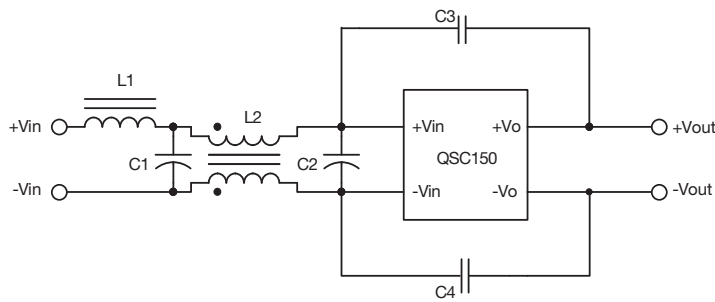

Model Number	C1	C2	C3	C4	L2
QSC15024S05	470uF/50V	470uF/50V	2200pF	2200pF	0.5mH
QSC15024S12	470uF/50V	470uF/50V	2200pF	2200pF	0.5mH
QSC15024S24	470uF/50V	470uF/50V	2200pF	2200pF	0.5mH
QSC15024S28	470uF/50V	470uF/50V	2200pF	2200pF	0.5mH
QSC15024S48	470uF/50V	470uF/50V	4700pF	4700pF	0.5mH
QSC15048S05	220uF/100V	220uF/100V	2200pF	2200pF	0.5mH
QSC15048S12	220uF/100V	220uF/100V	2200pF	2200pF	0.5mH
QSC15048S24	220uF/100V	220uF/100V	2200pF	2200pF	0.5mH
QSC15048S28	220uF/100V	220uF/100V	2200pF	2200pF	0.5mH
QSC15048S48	220uF/100V	220uF/100V	4700pF	4700pF	0.5mH

C1, C2 aluminium such as type Nippon Chemi-Con KY series

C3, C4 Ceramic such as Murata KX series

L2 such as Tokin SC-15-05J

L1 short