

100W Baseplate cooled

DC-DC converters

The QSB100 series offers a compact 100W DC-DC converter solution in an industry standard ¼ brick package, with integral baseplate for conduction cooling. Available in two input ranges, covering 9V to 36VDC & 18V to 75VDC.

Standard features are: output voltage trim, remote sense, remote On/Off, a wide operating temperature range and includes protection for over current, over temperature and over voltage.

The QSB100 is highly suited to telecommunications, distributed power architectures, battery operated equipment, industrial electronics, mobile equipment and many other applications.



Features

- ▶ Regulated single outputs 3.3V to 24VDC
- ▶ 4:1 input ranges 9V to 36VDC & 18V to 75VDC
- ▶ Baseplate cooled ¼ brick package
- ▶ 1.5kVDC isolation
- ▶ Output trim ±10%
- ▶ Remote sense
- ▶ Remote On/Off
- ▶ -40°C to +100°C operating temperature
- ▶ 3 year warranty

Applications

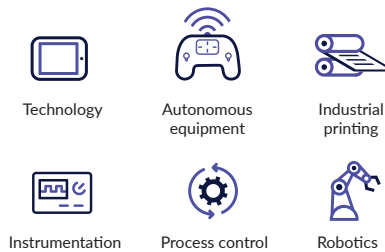

Dimensions

57.9 x 36.8 x 12.7mm (2.28" x 1.45" x 0.5")
¼ brick package

Models & ratings

Model number ⁽³⁾	Input voltage	Output voltage	Output current	Input current ⁽⁴⁾		Efficiency
				No load	Full load	
QSB10024S3V3	9-36VDC (24VDC nominal)	3.3VDC	30.00A	120mA	4.80A	86.0%
QSB10024S05		5.0VDC	20.00A	120mA	4.82A	86.5%
QSB10024S12		12.0VDC	8.30A	80mA	4.80A	86.5%
QSB10024S15		15.0VDC	6.70A	80mA	4.84A	86.5%
QSB10024S24		24.0VDC	4.17A	80mA	4.79A	87.0%
QSB10048S3V3	18-75VDC (48VDC nominal)	3.3VDC	30.00A	60mA	2.37A	88.0%
QSB10048S05		5.0VDC	20.00A	60mA	2.37A	88.0%
QSB10048S12		12.0VDC	8.30A	30mA	2.36A	88.0%
QSB10048S15		15.0VDC	6.70A	30mA	2.38A	88.0%
QSB10048S24		24.0VDC	4.17A	30mA	2.37A	88.0%

Notes:

1. Ripple & noise is measured with a 10µF tantalum capacitor and 1.0µF ceramic capacitor across output.
2. Logic compatibility: Ref to -ve input. Module On = open circuit. Module Off = <0.8VDC.
3. Add suffix 'N' to the model number to receive the unit with negative logic Remote On/Off.
4. Input current specified at 24 V for 9-36VDC and 48V for 18-75VDC models.

Input

Characteristic	Minimum	Typical	Maximum	Units	Notes & conditions
Input voltage range	9		36	VDC	24VDC
	18		75		48VDC
Undervoltage lockout		8.8		VDC	On (24VDC)
		8.0			Off (9-36VDC)
Input surge		50		VDC	24VDC (for 100ms)
		100			48VDC (for 100ms)
Input current	See models and ratings table				
Input reverse voltage protection	None				
Input filter	Pi type				

Output

Characteristic	Minimum	Typical	Maximum	Units	Notes & conditions
Output voltage trim		±10		%	See application notes
Initial set accuracy			±1.5	%	
Line regulation			±0.2	%	Measured from high line to low line
Load regulation			±0.2	%	Measured from 0-100% load
Transient response			5	%	Maximum deviation, recovery to within 1% in 500µs, 25% step load change
Start up delay		100		ms	
Ripple and noise			100	mV pk-pk	3.3 & 5VDC, 20MHz bandwidth
			150		12 & 15VDC, 20MHz bandwidth
			280		24VDC, 20MHz bandwidth
Overvoltage protection	115		140	%	
Short circuit protection	Continuous				
Thermal shutdown		>100		°C	Baseplate temperature
		<70			Restart
Temperature coefficient		±0.03		%/°C	
Current limit	110		160		Of nominal output
Remote On/Off	See models and ratings notes				
Remote Sense	Compensates up to 10% of Vout nominal, total of output trim and remote sense				

General

Characteristic	Minimum	Typical	Maximum	Units	Notes & conditions
Efficiency	See models & ratings table				
Isolation: input to output	1500			VDC	
Isolation: input to case	1500			VDC	
Isolation: output to case	1500			VDC	
Isolation resistance	10 ⁷			Ω	
Isolation capacitance		100		pF	
Switching frequency		250		kHz	
Power density		153.67 (60.5)		W/cm ² (W/in ²)	
Mean time between failure		730		khrs	MIL-HDBK-217F, +25°C GB

Environmental

Characteristic	Minimum	Typical	Maximum	Units	Notes & conditions
Operating base plate	-40		+100	°C	See derating curve
Storage temperature	-55		+105	°C	
Operating humidity			90	%RH	Non-condensing
Cooling	Baseplate cooled				

EMC: emissions

Phenomenon	Standard	Test level	Notes & conditions
Conducted	EN55032	A	With external components
Radiated	EN55032	A	With external components

EMC: Immunity

Phenomenon	Standard	Test level	Criteria	Notes & conditions
ESD immunity	EN61000-4-2	2	B	
Radiated	EN61000-4-3	3V/m	A	
EFT/burst	EN61000-4-4	Level 1	A	
Surges	EN61000-4-5	Level 1	A	
Conducted	EN61000-4-6	3Vrms	A	

Safety approvals

Safety agency	Standard	Test level	Notes & conditions
UL	UL60950-1		
EN	EN62368-1		
CE	Meets all applicable directives		
UKCA	Meets all applicable legislation		

Application notes

Output Voltage Trim

Voltage trim down

Connect trim resistor R_{trim} between Trim pin and -Sense pin.

$$R_{trim\ down} = \left(\frac{511}{\Delta\%} - 10.22 \right) k\Omega$$

$$\text{Where: } \Delta\% = \left(\frac{V_{nom} - V_{des}}{V_{nom}} \right) \times 100$$

Voltage trim up

Voltage trim up, Connect trim resistor R_{trim} between Trim pin and +Sense pin

$$R_{trim\ up} = \left(\frac{5.11 V_{nom} (100 + \Delta\%)}{1.225 \times \Delta\%} - \frac{511}{\Delta\%} - 10.22 \right) k\Omega$$

$$\text{Where: } \Delta\% = \left(\frac{V_{des} - V_{nom}}{V_{nom}} \right) \times 100$$

Derating curve

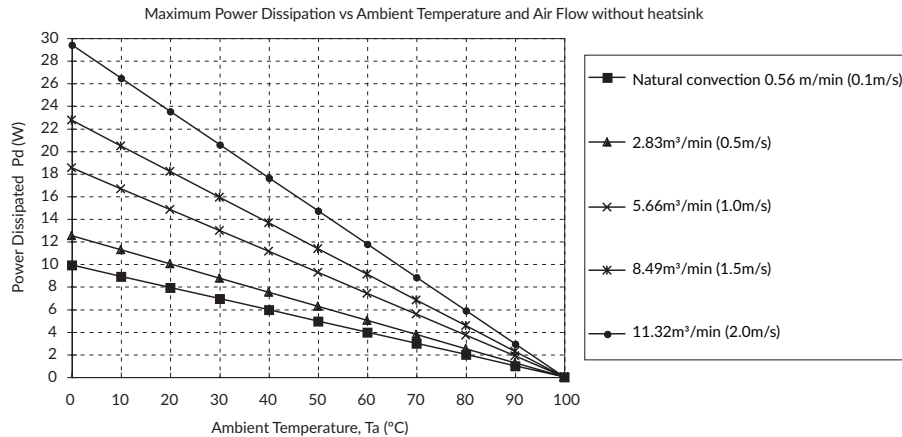

Air Flow Rate	Typical Rca
Natural Convection 0.56m³/min (0.1m/s)	10.1°C/W
2.83m³/min (0.5m/s)	8.0°C/W
5.66m³/min (1.0m/s)	5.4°C/W
8.49m³/min (1.5m/s)	4.4°C/W
11.32m³/min (2.0m/s)	3.4°C/W

Rca = Thermal resistance from case to ambient

Mechanical details

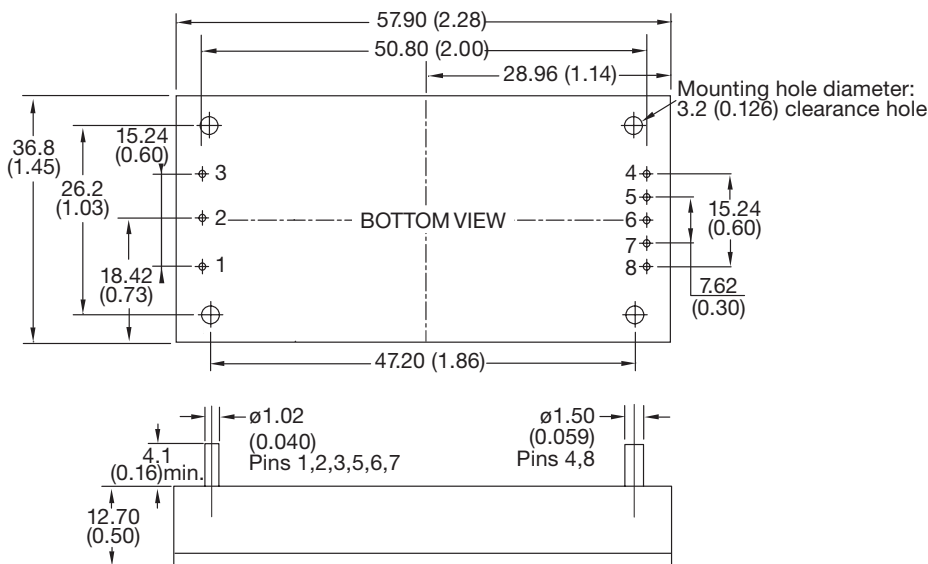

Pin connections	
Pin	Function
1	+Vin
2	Remote On/Off
3	-Vin
4	-Vout
5	-Sense
6	Trim
7	+Sense
8	+Vout

Notes:

- Dimensions are in mm (inches)
- Tolerances: x.xx (x.x) = ±0.5 (±0.02), x.xxx (x.xx) = ±0.25 (±0.01)

3. Weight: 66g (0.15lbs) approx

Specifications subject to change without notice.