

**300W** Baseplate cooled

DC-DC converters

The QSB300 series offers a compact 300W DC-DC converter solution in an industry standard ½ brick package, with integral baseplate for conduction cooling and a 350W peak power capability for 3s with 10% duty cycle. Available in two input ranges, covering 9V to 36VDC & 18V to 75VDC.

Standard features are: output voltage trim, remote sense, remote On/Off, a wide operating temperature range and includes protection for over current, over temperature and over voltage.

The QSB300 is highly suited to telecommunications, distributed power architectures, battery operated equipment, industrial electronics, mobile equipment and many other applications.



## Features

- ▶ Regulated single outputs 5V to 48VDC
- ▶ 4:1 input ranges 9V to 36VDC & 18V to 75VDC
- ▶ Baseplate cooled ½ brick package
- ▶ 350W peak power for 3s
- ▶ 1.5kVDC isolation
- ▶ Output trim ±10%
- ▶ Remote sense
- ▶ Remote On/Off
- ▶ -40°C to +100°C operating temperature
- ▶ 3 year warranty

## Applications

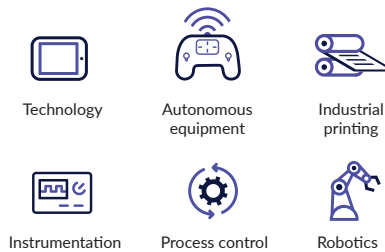

## Dimensions

60.9 x 57.9 x 12.7mm (2.40" x 2.28" x 0.5")  
½ brick package

## Models & ratings

Model number <sup>(1)</sup>	Input voltage	Output voltage	Output current		Input current		Efficiency <sup>(3)</sup>	Max. Capacitive Load
			Nom.	Peak <sup>(4)</sup>	No load	Full load		
QSB30024S05 <sup>(6)</sup>	9-36VDC (24V nominal)	5.0VDC	60.0A	70.00A	200mA	14.21A	88.0%	10000µF
QSB30024S12 <sup>(6)</sup>		12.0VDC	25.0A	29.16A	200mA	13.89A	89.5%	10000µF
QSB30024S24 <sup>(5)</sup>		24.0VDC	12.5A	14.58A	100mA	14.21A	91.5%	4700µF
QSB30024S28 <sup>(5)</sup>		28.0VDC	10.7A	12.50A	100mA	14.11A	90.0%	4700µF
QSB30024S48 <sup>(5)</sup>		48.0VDC	6.25A	7.29A	100mA	14.37A	91.0%	2200µF
QSB30048S05	18-75VDC (48V nominal)	5.0VDC	60.0A	70.00A	100mA	6.94A	90.0%	10000µF
QSB30048S12		12.0VDC	25.0A	29.16A	100mA	6.94A	89.0%	10000µF
QSB30048S24		24.0VDC	12.5A	14.58A	80mA	6.98A	91.0%	4700µF
QSB30048S28		28.0VDC	10.7A	12.50A	80mA	6.94A	92.5%	4700µF
QSB30048S48 <sup>(5)</sup>		48.0VDC	6.25A	7.29A	80mA	7.02A	91.5%	2200µF

### Notes:

1. Add suffix 'N' to the model number to receive the unit with negative logic Remote On/Off.
2. Minimum of 1000µF for 24V<sub>in</sub> and 220µF for 48V<sub>in</sub> required on input.
3. Measured at nominal input voltage.

4. Peak Current is for max duration of 3s with 10% duty cycle. Average output power not to exceed 300W.
5. Models require minimum 220µF capacitor across output rails to maintain regulation.
6. QSB30025S05 requires minimum 470µF and QSB30024S12 requires minimum 330µF across output rails to maintain regulation.

## Input

Characteristic	Minimum	Typical	Maximum	Units	Notes & conditions
Input voltage range	9		36	VDC	24VDC
	18		75		48VDC
Input current	See models and ratings table				
Input reverse voltage protection	None				
Input filter	Pi network				
Undervoltage lockout	On: 8.8		Off: 8.0	VDC	24Vin
	On: 17.0		Off: 16.0		48Vin
Input surge		50		VDC	For 100ms, 24Vin
		100			For 100ms, 48Vin

## Output

Characteristic	Minimum	Typical	Maximum	Units	Notes & conditions
Output voltage trim		±10		%	See application notes
Initial set accuracy			±1.5	%	
Start up time		120			
Line regulation			±0.2	%	Measured from high line to low line
Load regulation			±0.2	%	Measured from 0-100% load
Transient response			5	%	Maximum deviation, recovery to within 1% in 500µs, 25% step load change
Ripple and noise		100	100	mV pk-pk	3.3 & 5VDC, 20MHz bandwidth
		120	150		12VDC, 20MHz bandwidth
		280	280		24 & 28VDC, 20MHz bandwidth
		480			48VDC, 20MHz bandwidth measured with 10µF tantalum and 1µF ceramic capacitor across output
Overvoltage protection	115		140	%	
Short circuit protection	Continuous				
Thermal shutdown		>105		°C	Case temperature
Temperature coefficient		±0.03		%/°C	
Current limit	120		140		Of nominal output

## General

Characteristic	Minimum	Typical	Maximum	Units	Notes & conditions
Efficiency	See models & ratings table				
Isolation: input to output			1500	VDC	Functional insulation
Isolation: input to case			1500	VDC	
Isolation: output to case			1500	VDC	
Isolation resistance		10		MΩ	
Isolation capacitance		2000		pF	
Switching frequency		220		kHz	
Case material	Plastic (DAP) with aluminium base plate. UL94V-0 rated. Meets EN45545-2				
Potting material	Epoxy UL94V-0				
Pin material	Copper with nickel and matte tin plate				
Solder profile			260	°C	With iron 450°C, 5s max. 1.5mm from case 10s max
Water wash	Use deionized water, do not soak. Dry thoroughly				
Power density		6.65 (109.0)		Wcm <sup>3</sup> (W/in <sup>3</sup> )	
Mean time between failure		300		khrs	MIL-HDBK-217F, +25°C GB
Weight		114 (0.25)		g (lb)	

## EMC: emissions

Phenomenon	Standard	Test level	Notes & conditions
Conducted	EN55032	A	With external components

## Signals and controls

Phenomenon	Standard	Test level	Notes & conditions
Remote on/off	Output is off if pin 2 is low (<1.8V) and on if high (≥3.5V) or open circuit, Reference to -ve input pin 4		
Remote sense	Compensates up to 10% of V <sub>out</sub> nominal, total of output trim and remote sense		

## Safety approvals

Safety agency	Standard	Test level	Notes & conditions
EN	EN62368-1		
UL	UL62368-1		Pending
CSA	Pending		
CE	Meets all applicable directives		
UKCA	Meets all applicable legislation		

## Application notes

### Input fusing and safety considerations

The QSB300 series converters have no internal fuse. In order to achieve maximum safety and system protection, always use an input line fuse.

We recommended a 60A time delay fuse for 24Vin models, and 30A for 48Vin models. It is recommended that the circuit have a transient voltage suppressor diode TVS (24 Vin SMCJ40A; 48 Vin, SMCJ78A) across the input terminal to protect the unit against surge or spike voltage and input reverse voltage (as shown).

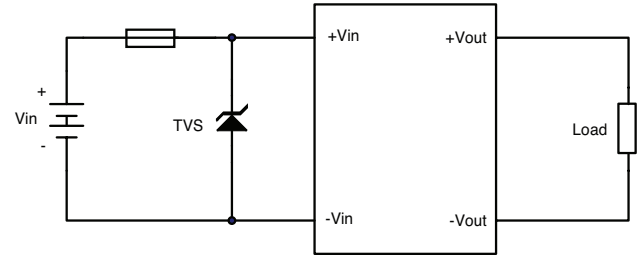

### Output voltage adjustment

The Trim input permits the user to adjust the output voltage up or down according to the trim range specification ( $\pm 10\%$  of nominal output).

This is accomplished by connecting an external resistor between the +Vout, +Sense and trim pin for trim up and between the trim and -Vout, -Sense pin for trim down, see figure. The trim pin should be left open if trimming is not required.

C1 > 220 $\mu$ F / 100V

For C2 see note 5 & 6 or max capacitive load in Models and Ratings table. A low ESR electrolytic capacitor is recommended.

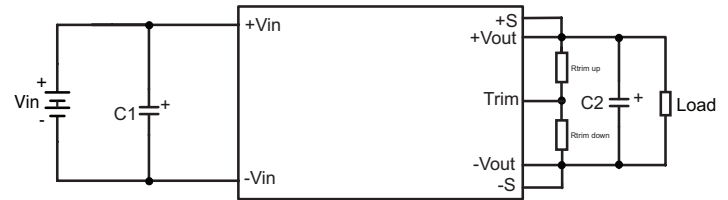

#### Voltage trim down

Connect trim resistor Rtrim between Trim pin and -Sense pin.

$$R \text{ trim down} = \left( \frac{511}{\Delta\%} - 10.22 \right) \text{ k}\Omega$$

$$\text{Where: } \Delta\% = \left( \frac{V_{nom} - V_{des}}{V_{nom}} \right) \times 100$$

#### Voltage trim up

Voltage trim up, Connect trim resistor Rtrim between Trim pin and +Sense pin

$$R \text{ trim up} = \left( \frac{5.11 V_{nom} (100 + \Delta\%)}{1.225 \times \Delta\%} - \frac{511}{\Delta\%} - 10.22 \right) \text{ k}\Omega$$

$$\text{Where: } \Delta\% = \left( \frac{V_{des} - V_{nom}}{V_{nom}} \right) \times 100$$

### Output voltage sensing

The module will automatically trim the output voltage via the sense pins to the default values either locally or at the load. If not required, the sense pins should be connected locally as indicated in the above example circuit.

### Efficiency vs load

#### QSB30048S28

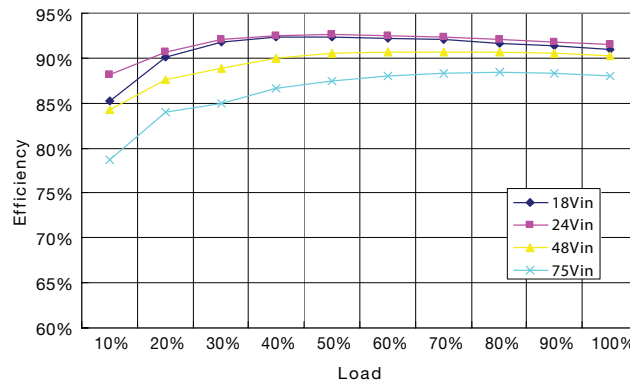

## Application notes

### EMC Considerations

#### Suggested circuits for conducted EMI Class A

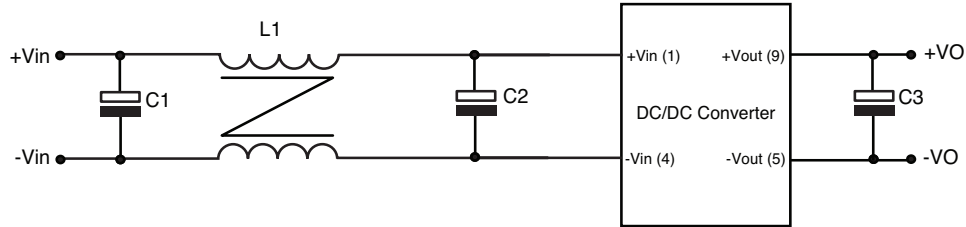

C1	C2	C3	L1
220 $\mu$ F/100V	220 $\mu$ F/100V	220 $\mu$ F	1.5mH

#### Notes:

220 $\mu$ F/100V NIPPON CHEMI-CON KMF series aluminum capacitors.  
C3 >220 $\mu$ F or as per Models and Ratings table

L1: Common mode choke, core p/n SM CM20 x 12 x 10

## Mechanical details

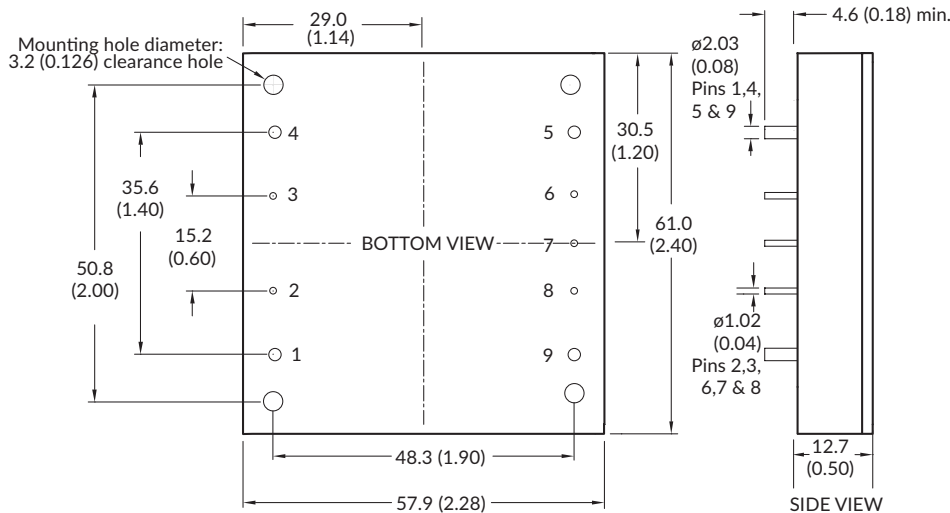

Pin connections	
Pin	Function
1	+Vin
2	Remote On/Off
3	Case
4	-Vin
5	-Vout
6	-Sense
7	Trim
8	+Sense
9	+Vout

#### Notes:

- Dimensions are in mm (inches)
- Tolerances: x.xx (x.x) =  $\pm 0.5$  ( $\pm 0.02$ ), x.xxx (x.xx) =  $\pm 0.25$  ( $\pm 0.01$ )

- Weight: 114g (0.25lbs) approx.
- Optional M3 x 0.5 threaded fixing add suffix -T