

**150W** Baseplate cooled

DC-DC converters

The QHL150 series provides a compact 150W DC-DC solution in an industry standard full brick package with a nominal 300VDC input and an operating range of 180 to 425VDC. This series of modules enables effective construction of distributed power architectures from AC front ends, PFC front ends, baseplate cooled ESG solutions and high voltage battery applications.

Utilizing the integral baseplate for conduction cooling gives the designer flexibility in system design. Constructed with reinforced insulation, the QHL series features an industrial operating temperature range and includes protection for over current, over temperature and over voltage.



## Features

- ▶ Regulated single outputs from 12 to 48VDC
- ▶ Output voltage trim -20%/+10%
- ▶ 180 to 425VDC input range
- ▶ 3.0kVAC isolation
- ▶ Industry standard ¼ brick package
- ▶ Baseplate cooled
- ▶ High efficiency up to 90%
- ▶ ITE safety approvals
- ▶ Short circuit, overvoltage & overtemperature protection
- ▶ Remote On/Off
- ▶ -40°C to +100°C operating temperature
- ▶ 3 year warranty

## Applications

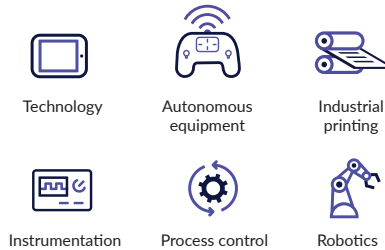

## Dimensions

57.9 x 36.8 x 12.7mm (2.28" 1.45" x 0.5")  
¼ Brick package

## Models & ratings

Model number	Input voltage	Output voltage	Output current	Input current <sup>(1)</sup>		Ripple & noise	Efficiency at Vin Nominal with full load	Max. capacitive load
				No load	Full load			
QHL150300S05	300VDC (180-425VDC)	5V	30.0A	10mA	0.58A	100mV	86%	10000µF
QHL150300S12		12V	12.5A		0.56A	150mV	89%	8800µF
QHL150300S15		15V	10.0A		0.56A	150mV	89%	8800µF
QHL150300S24		24V	6.30A		0.57A	100mV	88%	3300µF
QHL150300S28		28V	5.40A		0.57A	100mV	89%	3300µF
QHL150300S48		48V	3.20A		0.57A	200mV	89%	1000µF

### Notes:

1. Measured at 300V nominal input.
2. Peak to peak measured at 20MHz bandwidth and i) 10µF al. and 1µF ceramic capacitor across output for 48V model, ii) 10µF tantalum and 1µF ceramic capacitor across output for all other models
3. Recommended input capacitance of 150µF required to reduce input ripple voltage at -40°C operation or 68µF for operation to -20°C. See application notes.
4. Optional negative logic add suffix -N for module enable/disable function. See output table.

## Input

Characteristic	Minimum	Typical	Maximum	Units	Notes & conditions
Input voltage range	180		425	VDC	
Input current			1	A	180VDC input, 100% load
Undervoltage lockout		170		VDC	On
		160			Off
Lockout hysteresis		10		VDC	
Input transient voltage			500	VDC	For 100ms
Idle current		10		mA	No load
Standby model		3		mA	When module inhibited
Inrush current			0.1	A <sup>2</sup> s	ETS300 132-2
Recommended input fuse		2		A	Time delay type, see application note
Input reflected ripple current		30		mA pk-pk	Through 12μH inductor

## Output

Characteristic	Minimum	Typical	Maximum	Units	Notes & conditions
Output voltage	5		48	VDC	See models and ratings table.
Output trim	-20		+10	%	See application note.
Initial set accuracy			±1	%	At full load
Minimum load	No minimum load required				
Line regulation			±0.2	%	From minimum to maximum input at full load.
Load regulation			±0.2	%	From 0% to full load.
Transient response			±5.0	%	Maximum deviation, recovering to less than 1% in 500 μs for 25% step load change
Start up time		300		ms	
Output voltage rise time		30		ms	
Ripple & noise				mV pk-pk	See models and ratings table.
Overload Pprotection	110	125	160	%	
Short circuit protection					Continuous hiccup mode, with auto recovery.
Maximum capacitive load					See models and ratings table
Temperature coefficient			±0.02	%/°C	
Overvoltage protection	115	125	140	%	Of nominal output voltage
Remote on/off	Output is on if remote on/off (pin 2) is open or high (3.5-75VDC) with respect to pin 3 or -Vin Output turns off if remote on/off (pin 2) is low (<1.2VDC max) with respect to pin 3 or -Vin Default positive logic, for negative logic add suffix -N				

## Environmental

Characteristic	Minimum	Typical	Maximum	Units	Notes & conditions
Operating base plate temperature	-40		+100	°C	
Storage temperature	-55		+125	°C	
Thermal Protection		+105		°C	Auto recovery at 95°C typical
Humidity			95	%RH	Non-condensing.
Altitude			2000	m	Operating. Storage to 12000m.
Cooling	Baseplate cooled				
Shock and vibration	EN61373/MIL-STD-810F				

## General

Characteristic	Minimum	Typical	Maximum	Units	Notes & conditions
Efficiency		90		%	See Models and Ratings table
Isolation: input to output	3000			VAC	60s reinforced
Isolation: input to case	2500			VAC	60s basic
Isolation: output to case	500			VAC	60s functional
Switching frequency	330	360	390	khz	Fixed PWM
Isolation resistance	100			MΩ	
Case material	Plastic (DAP) with aluminium base plate. UL94V-0 rated.				
Potting material	Epoxy UL94V-0				
Pin material	Copper with nickel and matte tin plate				
Solder profile			260	°C	With iron 450°C, 5s max. 1.5mm from case 10s max
Water wash	Use deionized water, do not soak. Dry thoroughly				
Power density			5.4 (90)	W/cm <sup>3</sup> (W/in <sup>3</sup> )	
Mean time between failure	1000			khz	48V models, MIL-HDBK-217F, +25°C GB
	800				Others, MIL-HDBK-217F, +25°C GB
Weight			65.0 (0.143)	g (lbs)	

## EMC: emissions

Phenomenon	Standard	Test level	Notes & conditions
Conducted	EN55032	Class A	See application notes
Radiated	EN55032	Class A	

## Emissions - immunity

Phenomenon	Standard	Test level	Criteria	Notes & conditions
ESD immunity	EN61000-4-2	±6kV/±8kV	A	Contact discharge/air discharge
Radiated immunity	EN61000-4-3	20V/m	A	
EFT/burst	EN61000-4-4	±2kV	A	See application note
Surge	EN61000-4-5	±2kV	A	See application note
Conducted	EN61000-4-6	10Vrms	A	
Magnetic fields	EN61000-4-8	3A/m	A	

## Safety approvals

Safety agency	Standard	Test level	Notes & conditions
UL	UL/cUL60950-1		ITE
EN	EN62368-1		Evaluated to EN62368-1
CE	Meets all applicable directives		
UKCA	Meets all applicable legislation		

## Application notes

### Input fusing and safety considerations

The QHL150 series converters have no internal fuse. For safety and system protection, always use an input line fuse. A 2.0A time delay fuse is recommended. It is also recommended the circuit has a transient voltage suppressor diode (TVS) across the input terminals to protect the unit against surges, spikes and input reverse voltage (as shown). A suitable part is SMCJ440A.

### Output voltage sensing

The module will automatically trim the output voltage via the sense pins to the default values either locally or at the load. If not required, the sense pins should be connected locally as indicated in the example EMC circuit.

### Output voltage adjustment

The Trim input permits the user to adjust the output voltage up by 10% or down by 20%. This is accomplished by connecting an external resistor between the Trim pin and -sense to trim up, or between the trim pin and +sense to trim down.

#### To Trim Down (Rd)

Trim Down %	12VDC	15VDC	24VDC	28VDC	36VDC	48VDC
	Rtrim_down (kΩ)					
1	111.9	687.3	952	1704	2067	3295
2	53.88	327.1	452	807.8	987.5	1588
3	34.55	207	285.3	509.2	627.8	1020
4	24.88	147	202	359.9	447.9	735.1
5	19.08	111	152	270.3	340	564.5
6	15.21	86.97	118.6	210.6	268	450.8
7	12.45	69.82	94.85	168	216.6	369.5
8	10.38	56.95	77	136	178.1	308.6
9	8.77	46.95	63.11	111.1	148.1	261.2
10	7.48	38.94	52	91.17	124.1	223.3
11	6.425	32.39	42.9	74.88	104.5	192.2
12	5.547	26.93	35.33	61.31	88.17	166.4
13	4.803	22.32	28.92	49.82	74.33	144.5
14	4.166	18.36	23.42	39.98	62.47	125.8
15	3.613	14.93	18.66	31.44	52.19	109.5
16	3.13	11.93	14.5	23.98	43.2	95.28
17	2.704	9.277	10.82	17.39	35.26	82.74
18	2.324	6.923	7.556	11.54	28.21	71.58
19	1.985	4.817	4.632	6.298	21.9	61.61
20	1.68	2.921	2	1.583	16.22	52.63

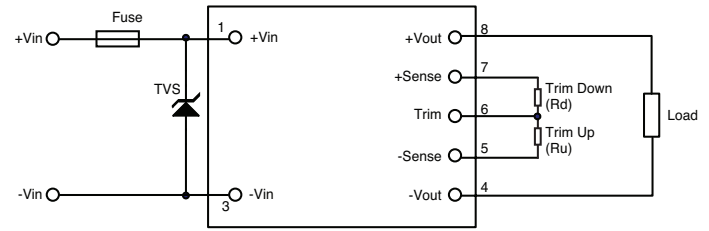

Suggested Basic Layout

#### To Trim Up (Ru)

Trim Down %	12VDC	15VDC	24VDC	28VDC	36VDC	48VDC
	Rtrim_up (kΩ)					
1	114.2	154.1	160.7	164.1	167.1	147.4
2	56.2	74.95	77.01	78.65	80.73	71.3
3	36.87	48.56	49.1	50.18	51.93	45.93
4	27.2	35.37	35.15	35.95	37.52	33.25
5	21.4	27.46	26.78	27.41	28.88	25.64
6	17.53	22.18	21.19	21.71	23.12	20.56
7	14.77	18.41	17.21	17.65	19.01	16.94
8	12.7	15.58	14.22	14.6	15.92	14.22
9	11.09	13.38	11.89	12.22	13.52	12.11
10	9.8	11.63	10.03	10.33	11.6	10.42

## Application notes

### Thermal Resistance - airflow derating curve - without heatsink

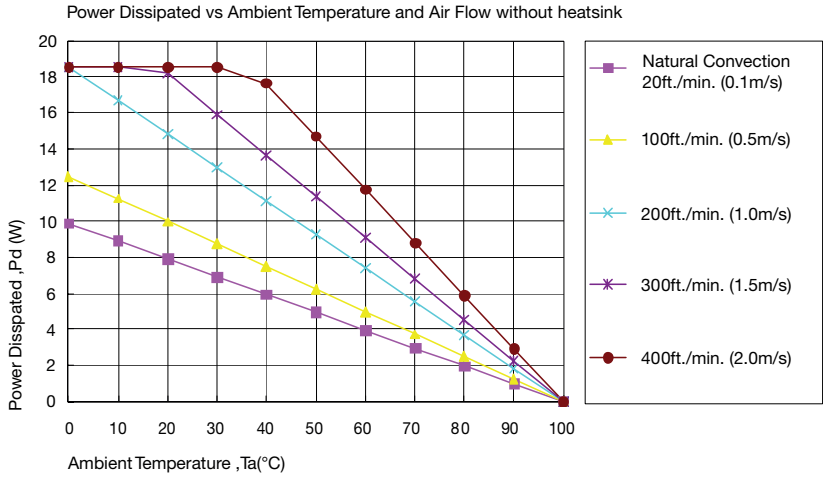

Air flow rate	Typical Rca
Natural Convection 20ft/min (0.1m/s)	10.1°C/W
100ft/min (0.5m/s)	8.0°C/W
200ft/min (1.0m/s)	5.4°C/W
300 t/min (1.5m/s)	4.4°C/W
400ft/min (2.0m/s)	3.4°C/W

### Example (without heatsink)

To determine the minimum airflow necessary for a QHL150300S12 operating at an input voltage of 300V, an output current of 12.5A, and a maximum ambient temperature of 40°C:

Determine Power dissipation (Pd):  $P_d = P_i - P_o = P_o(1-\eta)/\eta$ ,

$$P_d = 12V \times 12.5A \times (1-0.89) / 0.89 = 18.54$$

Where  $P_i$  = Input power,  $P_o$  = Output Power and  $\eta$  = Efficiency

Determine airflow from airflow derating graph using data points for  $P_d = 18.54W$  and  $T_a = 40^\circ C$

Minimum airflow = 400ft./min.

To check that the maximum case temp of 100°C is not exceeded:

Maximum temperature rise is

$$\Delta T = P_d \times R_{ca} = 18.54 \times 3.40 = 63.4^\circ C.$$

Maximum case temperature is

$$T_c = T_a + \Delta T = 40 + 63 = 103^\circ C < 100^\circ C.$$

Where:  $R_{ca}$  is the thermal resistance from case to ambient environment.  $T_a$  is ambient temperature and  $T_c$  is case temperature.

### Example Efficiency Curve

Example based on QHL150300S12

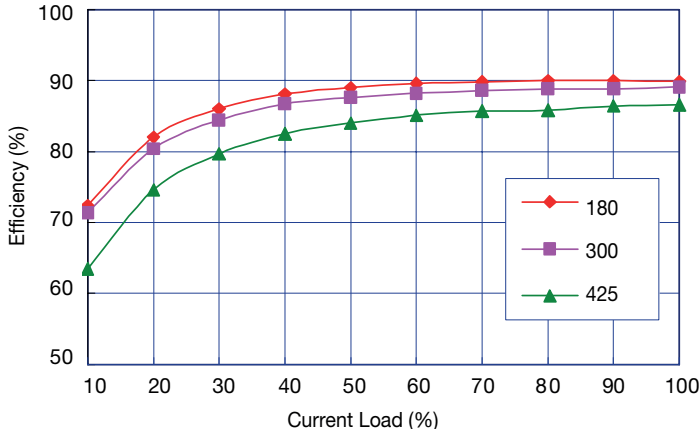

## Application notes

### Conducted and radiated emissions - Class A

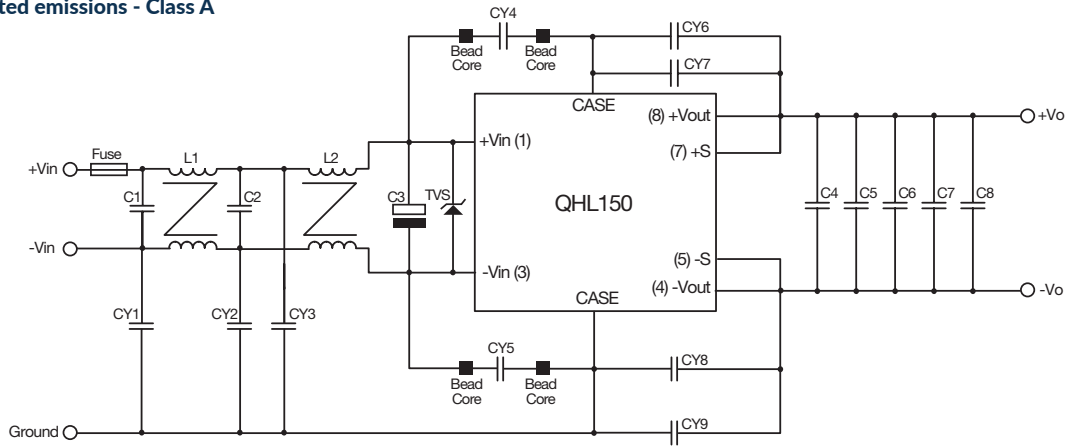

#### Notes:

C1	0.47 $\mu$ F/520V Polyester Film Capacitor	CY1,CY2	100pF CD Type
C2	0.1 $\mu$ F/630V 1812 X7R	CY3	1000pF CD Type
C3	Recommended 150 $\mu$ F, 450V aluminium capacitor for operation to -40°C type Nippon Chemi-Con KXG Series or equivalent. The value of C3 can be reduced to 68 $\mu$ F for operation to -20°C.	CY4,CY5	1500pF CD Type
C4,C5	4.7 $\mu$ F/100V X7R 1812	CY6,CY7,CY8,CY9	4700pF CD Type
C6,C7,C8	0.47 $\mu$ F/250V X7R 1210	L1, L2	5mH Common Choke
		Bead Core	2.8*1.7*1.2 SM
		Fuse	2A time delay
		TVS	440V <sub>R</sub> I <sub>pp</sub> 2.1A example, SMCJ440A

## Mechanical details

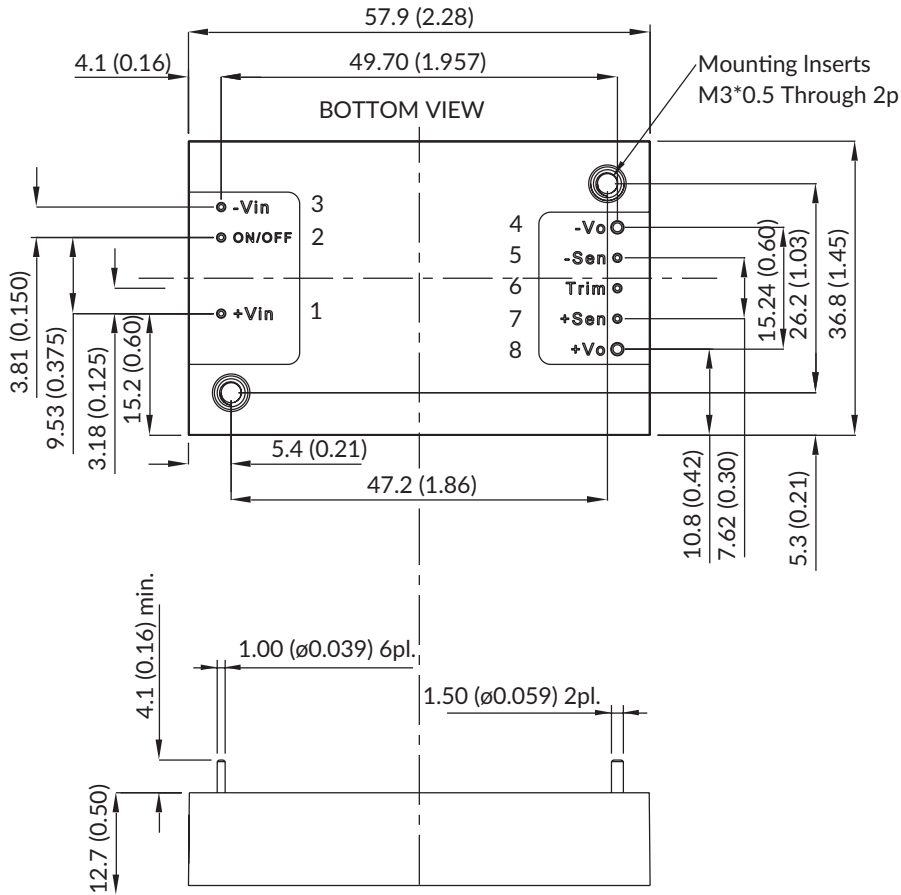

Pin connections	
Pin	Function
1	+Vin
2	Remote On/Off
3	-Vin
4	-Vout
5	-Sense
6	Trim
7	+Sense
8	+Vout

### Notes:

1. All dimensions are in inches (mm)
2. Weight: 65.0g (0.143lbs) approx.

3. Tolerance: x.xx = x.x ±0.5 (±0.02), x.xx = ±0.25 (x.xxx = ±0.01)
4. Optional M3 x 0.5 threaded baseplate fixing add suffix -T.