

The HPF3K0 series provides a suite of sophisticated digital control and monitoring functions, which equip the product for use in systems with a distributed control architecture. Medical and information technology safety approvals, high power density and class B conducted emissions are just part of the generous feature set, supporting use in a wide variety of applications.



Features

- ▶ Medical and Information Technology safety approvals
- ▶ Multiple serial data communication protocols: PMBus, CANopen, MODBUS and SCPI
- ▶ Programmable output voltage (0-105%)
- ▶ Programmable output current (0-110%)
- ▶ Intelligent fan speed control
- ▶ Parallel operation
- ▶ High efficiency – up to 93%
- ▶ Analogue and digital interfaces
- ▶ Graphical User Interface
- ▶ 5V/2A housekeeping supply
- ▶ SEMI F47 compliant
- ▶ 3 year warranty

Applications

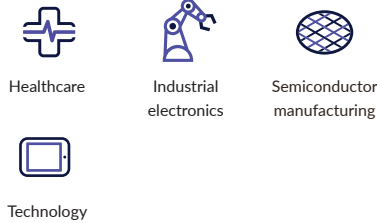

Dimensions

279.4 x 177.8 x 63.5 mm
(11.0" x 7.00" x 2.50" in)
(Not including connectors and fan guards)

Models & ratings

Model number ⁽¹⁾	Max output power	Output voltage V1			Output current		Efficiency ⁽²⁾
		Minimum	Nominal	Maximum	Minimum	Maximum	
HPF3K0PS24	3kW	0VDC	24VDC	25.2VDC	0.0A	125.0A	90.3%
HPF3K0PS36	3kW	0VDC	36VDC	37.8VDC	0.0A	83.3A	91.7%
HPF3K0PS48	3kW	0VDC	48VDC	50.4VDC	0.0A	62.5A	92.5%
HPF3K0PS60	3kW	0VDC	60VDC	63.0VDC	0.0A	50.0A	92.9%

Notes:

1. Standard models include PMBus, CANopen and RS485 interfaces. RS485 default is full-duplex. RS485 half-duplex can be configured via I²C or factory configured on request. To replace RS485 with RS232 or UART, contact sales.
2. Measured with 230VAC input and full load.

Input

Characteristic	Minimum	Typical	Maximum	Units	Notes & conditions
Input voltage (see application notes)	180		264	VAC	3kW
	90		180		1.5kW
Input frequency	47		63	Hz	Single phase input
Power factor		0.98			Complies with EN61000-3-2 for Class A @ 208V
Input current		19		A	90VAC 50% load or 180VAC 100% load
Inrush current			60	A	264VAC, 25°C cold start
Earth leakage current			450	µA	264VAC, 60Hz
Input protection	F25A/250V fuse fitted in line and neutral				

Output

Characteristic	Minimum	Typical	Maximum	Units	Notes & conditions
Output voltage	0		63	VDC	See Models and ratings table
Output set tolerance		±0.1		%	Nominal voltage irrespective of set voltage
Output voltage program	0		105	%	Of nominal, slew rate <40ms 10-105% & 105-10%. Max frequency of voltage program is 0.5Hz 0-5% load, 0.67Hz 5-10% load, 1Hz 10-20% load, 3Hz 20-100% load
Output voltage adjust	±10			%	Of set output via potentiometer 105% of nominal max.
Remote sense	Compensates for 1% max of nominal voltage per lead, 2% of total nominal voltage.				
Output current program	0		110	%	Of nominal
Minimum load	0			A	No minimum load required
Start up delay		1.8	2.3	s	Under all load and line conditions
Start up rise time			40	ms	
Hold up time	13	15		ms	208VAC at 100% load and 25°C
	10	12			208VAC at 100% load and -20°C
Line regulation			±0.1	%	Of nominal voltage. Input variation 90-264VAC
			±0.5		5V Standby
Load regulation			±0.5	%	0-100% or 100-0% load
			±2.0		5V Standby
Transient response			3	%	Deviation with a 50-75-50% load change. Output returns to within 1% in less than 500µs
Ripple & noise			1	%	Of nominal voltage. Peak-peak. 0 to 50°C 20MHz bandwidth with no additional filter.
			2.5		5V Standby
Overshoot			5	%	Turn on and turn off
Overvoltage protection	110		120	%	Of nominal voltage, latching. Cycle AC to reset. No protection for 5V Standby
Overtemperature protection	Auto resetting thermal protection				
Overload protection			110	% of max load	Tolerance: ±3% of max load. Default constant current mode behaviour, with user programmable protection threshold and behaviours. De-rated power limit of 1500W for operation at 90 - 180VAC input. 5V Standby: 5A max
Temperature coefficient			0.02	%/°C	Of nominal voltage and 5V standby
Short circuit protection	Constant current characteristics. Main output: Constant current characteristic. 5V Standby: Hiccup characteristic <5A max.				
Standby voltage		5		VDC	
Standby tolerance		±3		%	At 50% load
Standby current		2		A	

General

Characteristic	Minimum	Typical	Maximum	Units	Notes & conditions
Efficiency		92		%	230VAC, 100% load, 5V Standby at full load
Isolation: Input to output Input to ground Output to ground	4000			VDC	Reinforced insulation. 2 x MOPP. 6738VDC type test
	2500			VDC	Basic insulation. 1 x MOPP
	500			VDC	Functional insulation
Switching frequency		40		kHz	Fixed frequency PFC
	41		250	kHz	Variable frequency main converter
Power density			0.95 (15.6)	W/cm ³ (W/in ³)	
MTBF		3810		khrs	Telecordia SR-332 Issue 4, +25°C
Weight		4.0 (8.8)		kg (lb)	

Environmental

Characteristic	Minimum	Typical	Maximum	Units	Notes & conditions
Operating temperature	-20		+70	°C	Derate linearly from +50°C to 50% rated power at +70°C
Storage temperature	-40		+85	°C	
Cooling	Force air-cooled with intelligent fan speed control				
Humidity	5		95	%RH	Non-condensing
Operating altitude			5000	m	Medical
			5000		IT
Shock	±3 x 30g shocks in each plane, total 18 shocks. 30g = 11ms (±0.5ms) half sine. Conforms to EN60068-2-27 & EN60068-2-47				
Vibration	Single axis 10-500Hz at 2g sweep and endurance at resonance in all 3 planes. Conforms to EN60068-2-6				
Acoustic noise	<66dB L _{PA}				

Signals & controls

Digital control & monitoring function	
PMBus, CANopen and RS485	<p>Operation of the product using the fieldbus interfaces and associated protocols is defined in the supporting document 'HPA1K5/HPF3K0 Communication, Control and Status Specification'. Installation and use of the XP PS Manager software (graphical user interface) is defined in the supporting document 'XP PS Manager User Manual'. These documents are available through the XP Power website.</p> <p>Analog to digital monitoring accuracy: Vout monitor accuracy is ±0.1% of nominal voltage. Iout monitor accuracy is ±0.1% of full load. Vout and Iout setting accuracy is ±0.1% of nominal voltage/full load</p>
Analog hardware function	
V program	0V to 5V signal will program Vout from 0-105%. VProg accuracy ±1% of nominal output voltage. Minimum source current 0.5mA. In analog programming mode, Vout & Iout will be zero if either Vprog or Iprog is open circuit. Link PMBus_EN (pin 24) to SGND (pin 12) to enable analog mode
I program	0V to 5V signal will program the current limit from 0-110%. IProg accuracy ±2% of maximum current. Minimum source current 0.5mA
AC OK	Uncommitted opto-transistor. Circuit conducting means AC is within range. 2ms minimum warning time. See typical connection diagram on page 7
DC OK	Uncommitted opto-transistor. The operating threshold of this signal is driven from the VOUT_UV_FAULT digital user variable, which is 95% of nominal voltage by default and is programmable via PMbus. See typical connection diagram on page 7
Fan fail/Temp warning	3.3V logic signal referenced to SGND (pin 12). High = Fan FAIL and/or overtemperature, Low = Fan OK and temperature OK, unit switches off 10s after Fan Fail/Temp Warning alarm, auto recovery
Sync	Connect parallel units to synchronize output turn on following application of AC input
Current share	Connecting pin 23 on one unit to pin 23 on a like voltage unit will force the current to be shared. Up to 5 units can be paralleled. Current share accuracy ±3% of a single unit maximum current rating.
Inhibit	Uncommitted opto-diode. User programmable to become Enable signal. See typical connection diagram page 7

EMC: emissions

Phenomenon	Standard	Test level	Notes & conditions
Conducted	EN55011/EN55032	Class B	Class A <80% nominal output voltage
Radiated	EN55011/EN55032	Class A	
Harmonic currents	EN61000-3-2	Class A	Input > 115Vac @1.5kW, > 200Vac @3kW
Voltage flicker	EN61000-3-3		

EMC: immunity

Phenomenon	Standard	Test level	Criteria	Notes & conditions
ESD immunity	EN61000-4-2	4	A	±8kV contact / ±15kV air discharge
Radiated immunity	EN61000-4-3	3	A	
EFT/Burst	EN61000-4-4	3	A	
Surge	EN61000-4-5	Installation class 4	A	
Conducted	EN61000-4-6	3	A	
Magnetic field	EN61000-4-8	4	A	
Dips and interruptions	EN61000-4-11 (100VAC)	Dip 100%, 8.4ms	A	
		Dip 100%, 16.7ms	A	
		Dip 60%, 200ms	B	Criteria A derate to 320W
		Dip 30%, 500ms	B	Criteria A derate to 940W
		Dip 20%, 5000ms	B	Criteria A derate to 710W
		Int 100%, 5000ms	B	
	EN61000-4-11 (240VAC)	Dip 100%, 10ms	A	
		Dip 100%, 20ms	B	Criteria A derate to 1420W
		Dip 60%, 200ms	B	Criteria A derate to 1590W
		Dip 30%, 500ms	A	
		Dip 20%, 5000ms	A	
		Int 100%, 5000ms	B	
	EN60601-1-2 (100VAC)	Dip 100%, 10ms	A	
		Dip 100%, 20ms	A	
		Dip 60%, 100ms	B	Criteria A derate to 320W
		Dip 30% , 500ms	B	Criteria A derate to 940W
		Int 100%, 5000ms	B	
	EN60601-1-2 (240VAC)	Dip 100%, 10ms	A	
		Dip 100%, 20ms	B	Criteria A derate to 1420W
		Dip 60%, 100ms	B	Criteria A derate to 1590W
Dip 30%, 500ms		A		
Int 100%, 5000ms		B		
SEMI F47-0706	>200VAC input	A		

Safety approvals

Certification	Safety standard	Notes & conditions
CB report	IEC62368-1 Ed 2	Information technology
	IEC60601-1 Ed 3 Including Risk Management	Medical
UL	UL62368-1, CSA 22.2 No.62368-1, UL60950-1	Information technology
	ANSI/AAMI ES60601-1:2005 & CSA C22.2, No.60601-1:08	Medical
EN	EN62368-1	Information technology
	EN60601-1/2006	Medical
CE	Meets all applicable directives	
UKCA	Meets all applicable legislation	
Equipment protection class	Class I	See safety agency conditions of acceptability for details
Isolation	Means of protection	Notes & conditions
Primary to secondary	2 x MOPP (Means of patient protection)	IEC60601-1 Ed 3
Primary to earth	1 x MOPP (Means of patient protection)	
Secondary to earth	Functional insulation	

Application notes

Output derating

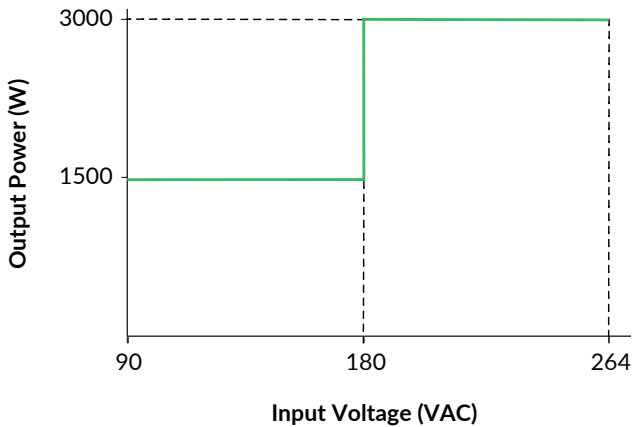

Output current programming

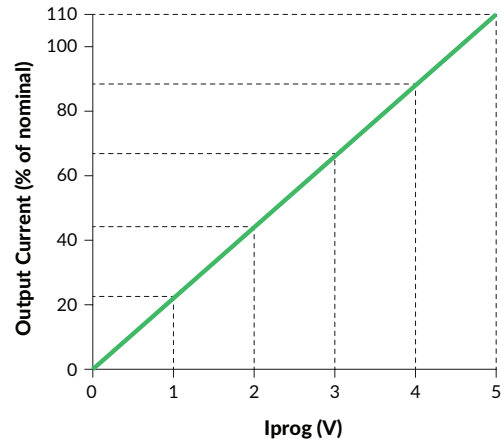

Output voltage programming

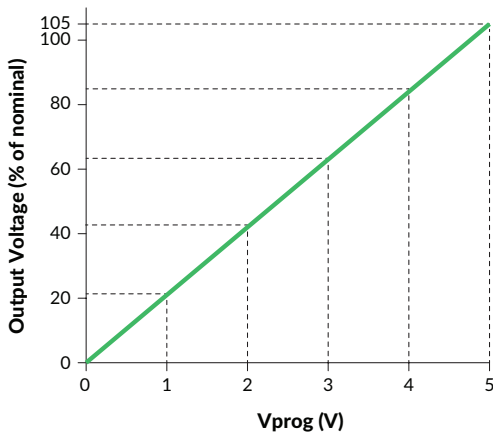

Dielectric strength testing

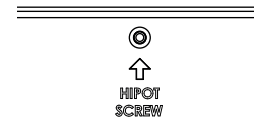

This product includes Gas Discharge Tubes as part of the Surge Immunity counter-measures. This screw must be removed during dielectric strength testing in the end-equipment, to prevent flashover to Earth.

Maximum applied voltage:

Live and neutral to earth: 2100Vdc

Input to Output: 2100Vdc

Re-install the screw after testing.

Signals & controls

Signal connections

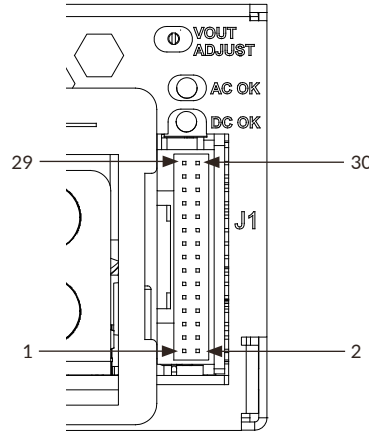

J1 signal connector connections

Pin	Function	Opto-isolator	Description
1	DCOK	Collector	See circuit diagram on page 7. Uncommitted opto-isolator. Circuit conducting means Vout is within range.
2	DCOK Return	Emitter	
3	Remote Inhibit	Anode	See circuit diagram on page 7. Uncommitted opto-diode. Diode conducting means output OFF.
4	Remote Inhibit Return	Cathode	
5	A0		I ² C Device Address Bit (Internal 10kΩ pull-up to 3.3V)
6	A1		I ² C Device Address Bit (Internal 10kΩ pull-up to 3.3V)
7	A2		I ² C Device Address Bit (Internal 10kΩ pull-up to 3.3V)
8	CANH		CAN Bus Communication using CANopen protocol
9	RS485_Y		RS485 Differential Serial Bus Communication
10	CANL		CAN Bus Communication using CANopen protocol
11	RS485_Z		RS485 Differential Serial Bus Communication
12	SGND		Signal Return
13	UART_RX / RS232_RX/RS485_A		RS485 Differential Serial Bus Communication or RS232 Serial Bus Communication or UART
14	I ² C SDA		I ² C (Internal 10kΩ pull-up to 3.3V)
15	UART_TX / RS232_TX/RS485_B		RS485 Differential Serial Bus Communication or RS232 Serial Bus Communication or UART
16	I ² C SCL		I ² C Bus Clock (Internal 10kΩ pull-up to 3.3V)
17	FAN_FAIL/TEMP WARNING		Fan Failure/Temp Warning Reporting (High means fan fails and/or overtemperature rating; 10kΩ pull up to 3.3V) See circuit diagram on page 7.
18	SYNC		Connect parallel units to synchronise output turn on
19	VPROG		0 to 5V to set Vout from 0 to 105% ⁽¹⁾ (50.8kΩ internal resistance between Vprog and SGND ⁽²⁾)
20	RS+		Positive Remote Sense
21	RS-		Negative Remote Sense
22	IPROG		0 to 5V to set Current Limit from 0 to 110% of rated current ⁽¹⁾ (50.8kΩ internal resistance between Iprog and SGND)
23	ISHARE		0 to 2.6V for current sharing of units in parallel
24	PMBUS_EN		Selecting Digital (open) or Analog (low) mode for VPROG & IPROG (Internal 10kΩ pull up to 3.3V)
25	ACOK	Collector	See circuit diagram on page 7. Uncommitted opto-isolator. Circuit conducting means AC is within range.
26	ACOK Return	Emitter	
27	5VSBY		5V/2A Standby
28	5VSBY		5V/2A Standby
29	5VSBY_RTN		5V/2A Standby Return
30	5VSBY_RTN		5V/2A Standby Return

Notes:

1. In analog mode, the default Vout and Iout settings are 0% when Vprog and Iprog are open circuit.
2. To activate analog mode, PMBus_EN must be pulled down to SGND. Default if left open is digital programming.

Signals & controls

DC OK

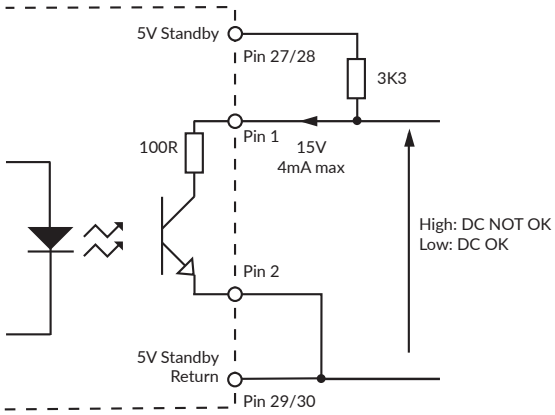

AC OK

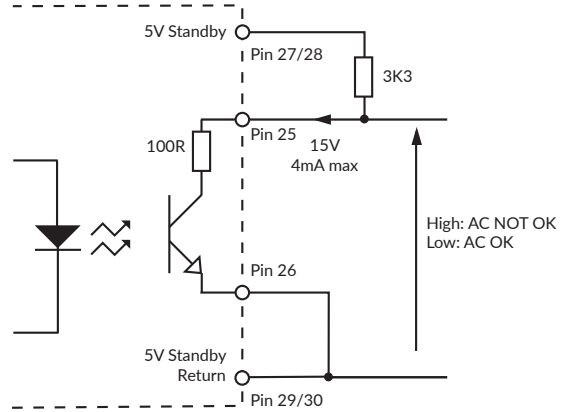

Fan fail/Temperature warning

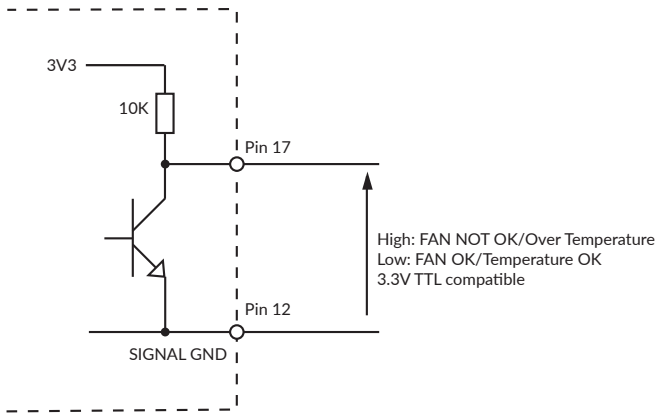

Inhibit

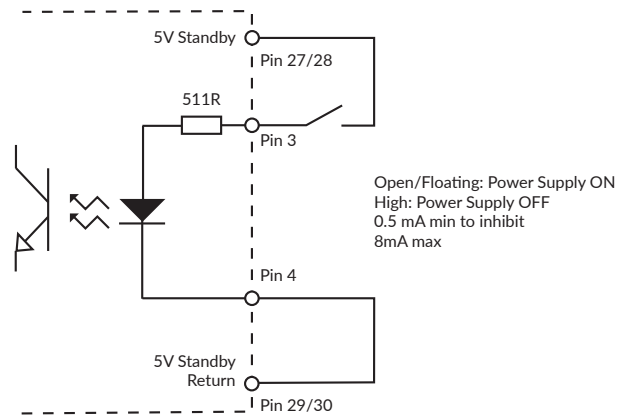

Signals & controls

Current share

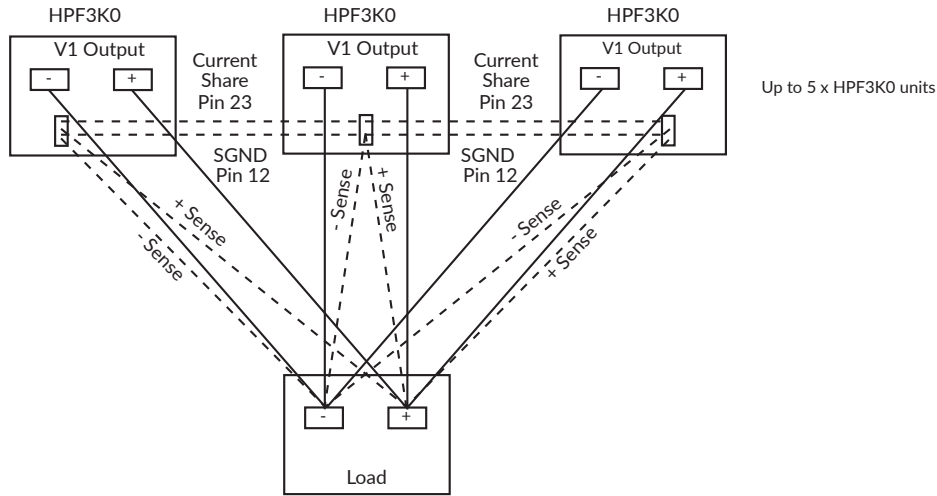

LED signals

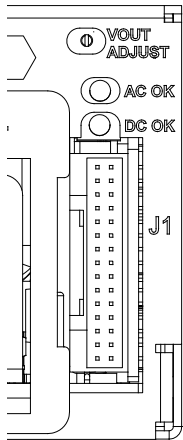

Conditions	LED state		Signals			
	AC OK	DC OK	AC OK	DC OK	FAN_FAIL/TEMP	Remote inhibit
AC input OK	ON	ON ⁽³⁾	Active	Active	Active Low	Inactive
AC below control system startup	OFF	OFF	Inactive	Inactive	Inactive	X ⁽²⁾
AC present but out of range or PFC failure or no primary to secondary communication	Blink (0.2s ON, 0.2s OFF)	OFF	High	High	Low	X ⁽²⁾
Output over voltage	ON	OFF	Active	Inactive	Active Low	Inactive
Current limit (Constant current response)	ON	Blink (0.2s ON, 0.2s OFF)	Active	Active or Inactive ⁽³⁾	Active Low	Inactive
Fan failure/Thermal shutdown	ON	OFF	Active	Inactive	Active High ⁽¹⁾	Inactive
Remote OFF	ON	Blink (1.0s ON, 1.0s OFF)	Active	Inactive	Active Low	Active
PMBus operation OFF	ON	Blink (1.0s ON, 1.0s OFF)	Active	Inactive	Active Low	Inactive

Notes:

- In case of fan failure, and/or Overtemperature, FAN_FAIL/Temp Warning signal will be set 10s before output shutdown.
- Don't care / not applicable.
- DC OK LED is ON if Output Voltage \geq VOUT_UV_FAULT_LIMIT, if Output Voltage $<$ VOUT_UV_FAULT_LIMIT, the DC OK LED will be OFF.

HPF3K0 series

Mechanical details

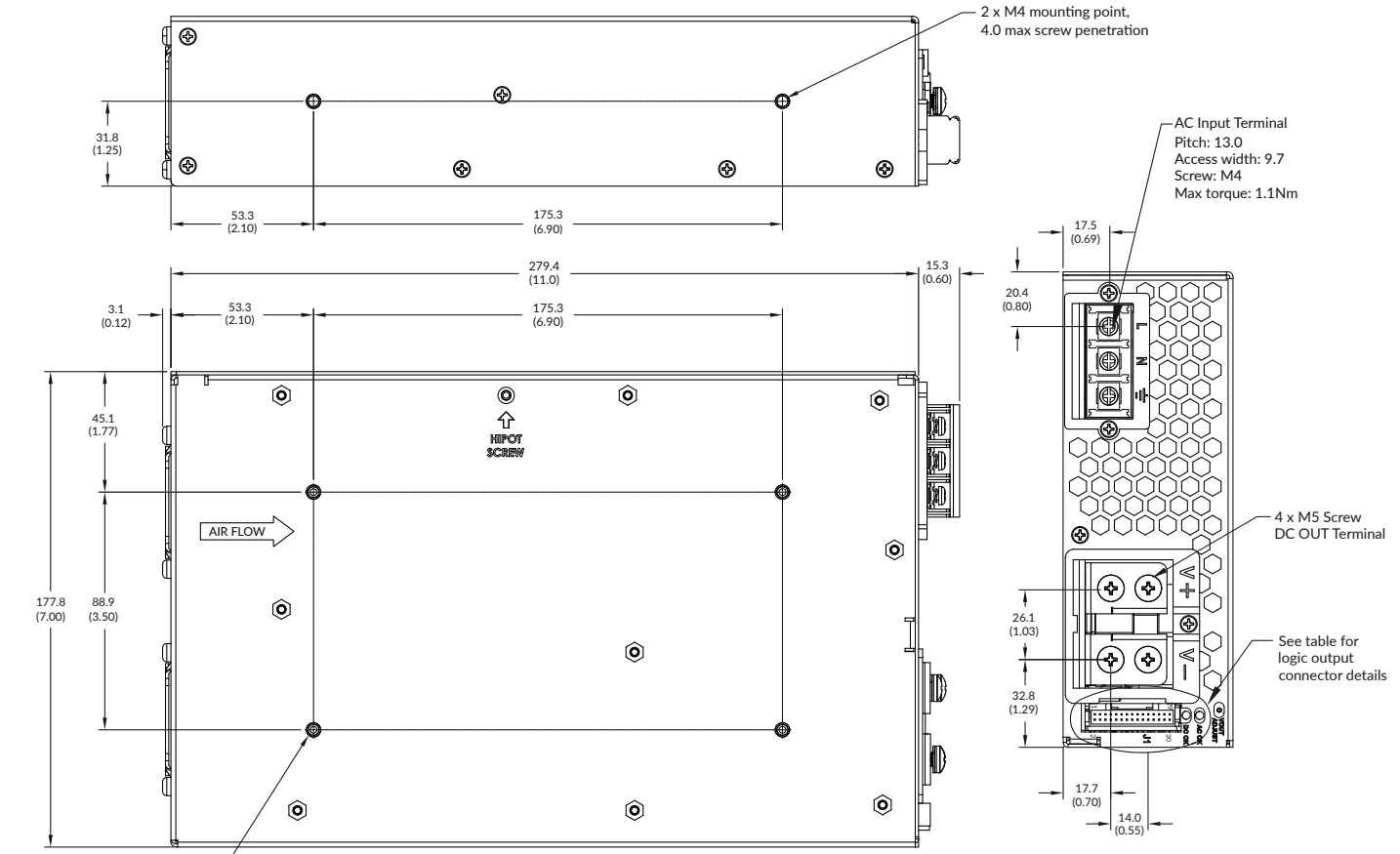

4 x M4 mounting point
4.0 max screw penetration

Pin	Function	Pin	Function
1	DCOK	16	I2C_SCL
2	DCOK_RTN	17	FAN_FAIL
3	RMT_INH	18	SYNC
4	RMT_INH_RTN	19	VPROG
5	I2C_A0	20	RS+
6	I2C_A1	21	RS-
7	I2C_A2	22	IPROG
8	CANH	23	ISHARE
9	RS485_Y	24	PMBUS_EN
10	CANL	25	ACOK
11	RS485_Z	26	ACOK_RTN
12	SGND	27	5VSBY
13	RS232_RX/RS485_A	28	5VSBY
14	I2C_SDA	29	5VSBY_RTN
15	RS232_TX/RS485_B	30	5VSBY_RTN

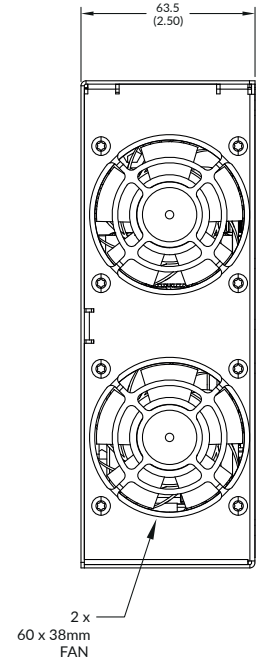

Notes:

- All dimensions are in mm (inches).
- Weight 4.0kg (8.8lbs).

- Signal Connector: JST part S30B-PUDSS-1 or equivalent. Mates with JST part PUDP-30V-S or equivalent. Contacts: SPUD-001T-P0.5 (26-22AWG), SPUD 002T-P0.5 (28-24AWG).

Specifications subject to change without notice.