

**5kW** Fan cooled

AC-DC power supplies

The HPT5K0 series delivers significant flexibility in a broad scope of industrial and scientific applications, through its sophisticated digital control and monitoring functions. High power density, class B conducted emissions and medical safety approvals up to 200VDC are highlights of the rich feature set. Constant voltage or current mode operation are readily configured via either linear voltage programming; a graphical user interface or one of the range of communication protocols included by default. The 400VDC and 800VDC models extend the series range, with specialised connectors, and a safety interlock.



This digital product series also retains conventional alarm and control features, such as active current sharing, remote On/Off and AC/DC OK signals, to deliver a highly extensible building block for scalable industrial systems.

## Features

- ▶ 3 phase 180 to 528VAC input – 3 wire & earth
- ▶ High efficiency – up to 94%
- ▶ Programmable output voltage (0-105%)
- ▶ Programmable output current (0-110%)
- ▶ Active current sharing in parallel configurations
- ▶ Safety interlock
- ▶ PMBus, CANopen, Modbus & SCPI protocols
- ▶ Rich suite of configurable signals & controls
- ▶ 5VDC/2A housekeeping supply
- ▶ SEMI F47 compliant
- ▶ 3 year warranty

## Applications

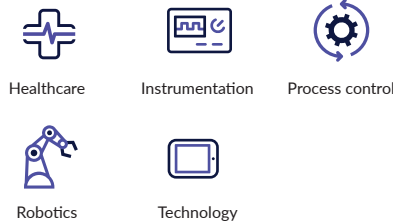

## Dimensions

330.2 x 127.0 x 127.0mm (13.0 x 5.0 x 5.0")

## Models & ratings

| Model number | Output voltage |         |         | Output current |         | Max output power | Efficiency <sup>(1)</sup> |
|--------------|----------------|---------|---------|----------------|---------|------------------|---------------------------|
|              | Minimum        | Nominal | Maximum | Minimum        | Maximum |                  |                           |
| HPT5K0TS048  | 0VDC           | 48VDC   | 50.4VDC | 0.0A           | 104.0A  | 5000W            | 93%                       |
| HPT5K0TS060  | 0VDC           | 60VDC   | 63VDC   | 0.0A           | 83.3A   | 5000W            | 93%                       |
| HPT5K0TS100  | 0VDC           | 100VDC  | 105VDC  | 0.0A           | 50.0A   | 5000W            | 93%                       |
| HPT5K0TS200  | 0VDC           | 200VDC  | 210VDC  | 0.0A           | 25.0A   | 5000W            | 93%                       |
| HPT5K0TS400  | 0VDC           | 400VDC  | 420VDC  | 0.0A           | 12.5A   | 5000W            | 94%                       |
| HPT5K0TS800  | 0VDC           | 800VDC  | 840VDC  | 0.0A           | 6.5A    | 5000W            | 94%                       |

### Notes:

1. Measured with 480VAC input and full load.

## Input

| Characteristic        | Minimum                               | Typical | Maximum | Units | Notes & conditions                              |
|-----------------------|---------------------------------------|---------|---------|-------|---|
| Input voltage         | 180                                   |         | 264     | VAC   | Maximum power output internally de-rated to 3kW |
|                       | 342                                   |         | 528     |       | 5kW power output                                |
| Input frequency       | 47                                    |         | 63      | Hz    |   |
| Power factor          |                                       | 0.96    |         |       | Complies with EN61000-3-2 for Class A           |
| Input current         |                                       |         | 10/11   | A     | Per phase, 342VAC (5kW)/180 VAC (3kW)           |
| Inrush current        |                                       |         | 60      | A     | Per phase, 528VAC (5kW)                         |
| Earth leakage current |                                       |         | 1.0     | mA    | 528VAC/60Hz                                     |
|                       |                                       |         | 3.3     |       | 528VAC/60Hz, single fault                       |
| Input protection      | F16A / 500V fuse fitted in each phase |         |         |       |   |
| Loss of phase         | Shut down after 0.5s, auto-recovery   |         |         |       |   |

## Output

| Characteristic             | Minimum  | Typical | Maximum   | Units         | Notes & conditions   |
|----------------------------|--|---------|-----------|---------------|--|
| Output voltage             | 0  |         | 840       | VDC           | See models and ratings table   |
| Output set tolerance       |  | ±0.1    |           | %             | Percentage of nominal voltage, irrespective of set voltage   |
| +5V housekeeping tolerance |  | ±3      |           | %             | 5VDC/2A housekeeping   |
| Output voltage program     | 0  |         | 105       | %             | Of nominal, slew rate <40ms 10-105% & 105-10%. Max frequency of voltage program is 0.5Hz 0-5% load, 0.67Hz 5-10% load, 1Hz 10-20% load, 3 Hz 20-100% load  |
| Output voltage adjust      | ±10  |         |           | %             | Of set output via potentiometer 105% of nominal max  |
| Output current program     | 0  |         | 110       | %             | Of rated output current. User programmable Setting accuracy ±0.1%  |
| Minimum load               | 0  |         |           | A             | No minimum load required   |
| Start up delay             |  | 1.8     | 2.3       | s             | Under all load and line conditions   |
| Smart preload              | The Smart Preload function applies a dynamically controlled load to the output, rapidly reducing the voltage to a safe level at shut down and supporting the slew rate listed for 'Output voltage program' |         |           |               |  |
| Start up rise time         |  |         | 100       | ms            |  |
| Hold up time               | 20   | 22      |           | ms            | 380VAC at 5kW and 25°C   |
|                            | 40   | 44      |           |               | 180VAC at 3kW and 25°C   |
| Line regulation            |  |         | ±0.5      | %             | Of nominal voltage   |
|                            |  |         | ±0.5      |               | 5VDC housekeeping  |
| Load regulation            |  |         | 1         | %             | 0-100% or 100-0% load  |
|                            |  |         | 2         |               | 5VDC housekeeping  |
| Transient response         |  |         | 3         | %             | Deviation with a 50-75-50% load change. Output returns to within 1% in less than 500µs   |
| Ripple & noise             |  |         | 1/2.5     | %             | Of nominal voltage/5VDC housekeeping. Measured with 20MHz bandwidth limited oscilloscope 0-50°C.   |
| Overshoot                  |  |         | 5         | %             | Turn on & turn off   |
| Overvoltage protection     | 110  |         | 120       | %             | Of nominal voltage, latching. Cycle AC to reset. No protection for 5VDC Standby  |
| Overtemperature protection | Auto resetting thermal protection  |         |           |               |  |
| Overload protection        |  |         | 110%, ±3% | % of max load | User programmable current limit set point. Maximum 110%. Constant current characteristic, with auto-recovery. For low line (180-342VAC), power limited to 3.0kW until current limit threshold. 5V Housekeeping: <5A max. |
| Temperature coefficient    |  |         | 0.03      | %/°C          | Of nominal voltage   |
| Short circuit protection   | Constant current characteristics. 5VDC housekeeping: Foldback characteristic <5A max   |         |           |               |  |
| Remote sense               | Compensates for maximum 1% of nominal voltage per lead, 2% total. Not fitted on 200-800VDC models  |         |           |               |  |

## General

| Characteristic                    | Minimum   | Typical    | Maximum | Units             | Notes & conditions  |      |
|-----------------------------------|---|------------|---------|-------------------|---|------|
| Efficiency                        | 93  | 94         |         | %                 | Between 480–528VAC, full load on main and housekeeping outputs.   |      |
|                                   | 91.5  | 92.5       |         |                   | At 342VAC, full load.   |      |
| Isolation all models:             |   |            |         |                   |   |      |
| Input to output                   | 6000  |            |         | VDC               | Rating for complete assembly with HI-POT screw removed. Maximum electric strength test voltage is 2121VDC with screw installed. |      |
| Input to ground                   | 4000  |            |         |                   |   |      |
| 48-200V models: output to ground  | 500   |            |         | VDC               |   |      |
| 400-800V models: output to ground | 4000  |            |         | VDC               | User connectors J1, J2, J3. ES1 classification for IEC62368-1. Circuits are referenced to Earth.                                |      |
|                                   | communications to ground  |            |         |                   |   | N/A  |
|                                   | communications to output  |            |         |                   |   | 4000 |
| Outputs in series                 | The 400VDC & 800VDC models are not safety approved for operation in series. |            |         |                   |   |      |
| Power density                     |   |            | 15.38   | W/in <sup>3</sup> |   |      |
| MTBF                              |   | 450        |         | kHrs              | Telcordia SR-332, Issue 2, at 25°C  |      |
| Weight                            |   | 5.7 (12.5) |         | kg (lb)           |   |      |

## Environmental

| Characteristic                | Minimum   | Typical | Maximum | Units | Notes & conditions                                   |
|-------------------------------|---|---------|---------|-------|--|
| Operating temperature         | -20   |         | 70      | °C    | Derate linearly from 50°C to 50% rated power at 70°C |
| Storage temperature           | -40   |         | +85     | °C    |  |
| Cooling                       |   |         |         |       | Force-cooled with intelligent fan speed control      |
| Humidity                      | 5   |         | 95      | %RH   | Non-condensing                                       |
| Switching frequency           | 55  | 60      | 65      | kHz   | Fixed frequency PFC, all models                      |
|                               | 40  |         | 250     |       | Variable frequency main convertor, 48–200VDC         |
|                               | 59  |         | 230     |       | Variable frequency main convertor, 400–800VDC        |
| Operating altitude: 48 – 200V |   |         | 3000    | m     | Medical  |
|                               |   |         | 5000    |       | ITE  |
| Operating altitude 400 – 800V |   |         | 3000    | m     | ITE  |
| Transport altitude            |   |         | 10000   | m     |  |
| Shock                         | ±3 x 30g shocks in each plane, total 18 shocks. 30g = 11ms (±0.5 ms) half sine. Conforms to EN60068-2-27 & EN60068-2-47 |         |         |       |  |
| Vibration                     | Single axis 10-500Hz at 1.5g sweep and endurance at resonance in all 3 planes. Conforms to EN60068-2-6                  |         |         |       |  |
| Acoustic noise                | <60dB L <sub>pa</sub>   |         |         |       |  |

## Signals & controls

|                                     | Digital control & monitoring functions  |
|-------------------------------------|---|
| PMBus, CANopen, Modbus RTU and SCPI | <p>Operation of the product using the distributed control interfaces and associated protocols, is defined in the supporting document 'HPT5K0/HPL5K0 Communication, Control and Status Specification'. Installation and use of the XP Insight graphical user interface, is defined in the supporting document 'XP Insight User Manual'. These documents are available through the XP Power website.</p> <p>Digital control provides the opportunity to create application specific behaviours for output voltage and current; slew rates; alarm levels and many more features. These can be permanently saved to the PSU and to a file, for batch configuration.</p> <p>Real-time control provides the opportunity to integrate the product into a digital control loop, create power profiles and monitor the product status.</p> <p>The SCPI command language is available over RS485, as an alternative to Modbus RTU, through user settings.</p> <p>Vout monitor/setting accuracy is <math>\pm 1\%</math> of nominal. Iout monitor/setting accuracy is <math>\pm 2\%</math> of full load</p> |
|                                     | Analogue hardware functions   |
| V program                           | Linear, proportional control of the output voltage. To activate analogue programming, link the PMBUS_EN signal to Iso Gnd on 400-800VDC, or to SGND on 48-200VDC models. 0-5VDC input will program Vout from 0- 05%. Vprog accuracy: $\pm 1\%$ of nominal output voltage. Minimum source current: 0.5mA. In this mode, no output will result if either Vprog or Iprog are open circuit.   |
| I program                           | Linear, proportional control of output current limit and changeover to constant current mode. 0-5VDC input will program the current limit from 0-110%. Iprog accuracy: $\pm 2\%$ of output current rating. Minimum source current 0.5mA.  |
| AC OK                               | Uncommitted opto-transistor. Circuit conducting means AC input is within range. User configurable. Minimum 2ms warning before output shutdown. See typical connection diagram on page 10 & 11.  |
| DC OK                               | Uncommitted opto-transistor. Logic is user configurable. The operating threshold of this signal is driven from the digital user variable VOUT_UV_FAULT, set to 95% of nominal voltage by default. See typical connection diagram on page 10 & 11.   |
| Remote on/off                       | Uncommitted opto-diode. Supplied configured as Active = Inhibit. The input can be re-configured to Active = Enable and also linked to the Safety Interlock as a reset/re-start function, when integrated into a machine safety system.  |
| Fan fail/temp warning               | Provides 10s warning of Fan Fail or Over Temperature conditions. 3.3V TTL compatible signal, referenced to Iso Gnd/SGND. High = Fan Fail or Over-temp. Low = Fan and temperature OK. Auto-recovery.   |
| Sync                                | Synchronise the output start-up of up to five units of identical HPT5K0 model, connected in parallel, following application of AC input. Link the Sync pins and the relevant Iso Gnd or SGND pins between the units.<br>CAUTION: This signal is part of the DC power output circuit, classed as energy source 3 (ES3) for IEC62368-1. Appropriate safeguards must be employed in the end-equipment.   |
| Current share                       | Balance output current between up to five units of identical HPT5K0 model, connected in parallel, by linking the Current Share pins between units. Sharing accuracy $\pm 3\%$ of a single unit current rating. CAUTION: This signal is part of the DC power output circuit, classed as energy source 3 (ES3) for IEC62368-1. Appropriate safeguards must be employed in the end-equipment.  |
| Safety interlock input              | Uncommitted opto-diode. Designed to meet ISO13849-1, performance level 'd', this input provides non-software based shutdown and prevention of unexpected start-up, when used in combination with Remote ON/OFF.   |

### Use of the safety interlock

The HPT5K0TS400 and 800 models feature a safety interlock, designed to meet the requirements of ISO13849-1 performance level 'd' and ISO13849-2. The opto-isolated input drives two signal pathways, one of which bypasses digital processor control entirely, to disable the main energy switching FETS. The interlock input MUST be active to achieve a DC power output. For users not wanting the full functionality, a continuous input may be simply configured through use of the 5VDC Housekeeping supply.

The Interlock and Remote ON/OFF inputs may be configured to activate a reset function, such that after an AC input failure, or application of the interlock input, an OFF to ON state change must be applied at the Remote ON/OFF input. This reset function provides the prevention of unexpected start-up required by the safety standard and is identified as IL\_INH\_LINK. Configuration is achieved via the XP Insight application or bit 6 of PMBus command 0xD6 USER\_CONFIGURATION.

The Interlock status may be monitored via XP Insight or bit 7 of PMBus command 0x7F STATUS\_OTHER. Both the Remote ON/OFF (hardware) input and the PMBus command 0x01 OPERATION must be in the ON state to enable the output. Additional information, including logic truth tables for the available configurations of the interlock are provided in the HPT5K0 User Manual.

## Emissions - EMC

| Phenomenon        | Standard    | Test level | Notes & conditions         |
|-------------------|-------------|------------|----------------------------|
| Conducted         | EN55032     | Class B    |                            |
| Radiated          | EN55032     | Class A    |                            |
| Harmonic currents | EN61000-3-2 | Pass       | Class A equipment category |
| Voltage flicker   | EN61000-3-3 |            |                            |

## Emissions - immunity

| Phenomenon                  | Standard                      | Test level                   | Criteria | Notes & conditions                 |
|-----------------------------|-------------------------------|------------------------------|----------|------------------------------------|
| ESD immunity                | EN61000-4-2                   | 4                            | A        | ±8kV contact / ±15kV air discharge |
| Radiated immunity           | EN61000-4-3                   | 3                            | A        |                                    |
| EFT/burst                   | EN61000-4-4                   | 3                            | A        |                                    |
| Surge                       | EN61000-4-5                   | Installation class 4         | A        |                                    |
| Conducted                   | EN61000-4-6                   | 3                            | A        |                                    |
| Magnetic field              | EN61000-4-8                   | 4                            | A        |                                    |
| Dips and interruptions      | EN61000-4-11<br>(200/380 VAC) | Dip 100% (0VAC), 8.4ms       | A        |                                    |
|                             |                               | Dip 100% (0VAC), 16.7ms      | A        |                                    |
|                             |                               | Dip 60% (80/152VAC), 200ms   | A        |                                    |
|                             |                               | Dip 30% (140/266VAC), 500ms  | A        |                                    |
|                             |                               | Dip 20% (160/304VAC), 5000ms | B        |                                    |
|                             |                               | Int 100% (0VAC), 5000ms      | B        |                                    |
|                             | EN61000-4-11<br>(240/480 VAC) | Dip 100% (0VAC), 10ms        | A        |                                    |
|                             |                               | Dip 100% (0VAC), 20ms        | A        |                                    |
|                             |                               | Dip 60% (96/192VAC), 200ms   | A        |                                    |
|                             |                               | Dip 30% (168/336VAC), 500ms  | A        |                                    |
|                             |                               | Dip 20% (192/384VAC), 5000ms | B        |                                    |
|                             |                               | Int 100% (0VAC), 5000ms      | B        |                                    |
|                             | EN60601-1-2<br>(200/380 VAC)  | Dip 100% (0VAC), 10ms        | A        |                                    |
|                             |                               | Dip 100% (0VAC), 20ms        | A        |                                    |
|                             |                               | Dip 60% (80/152VAC), 100ms   | A        |                                    |
|                             |                               | Dip 30% (140/266VAC), 500ms  | A        |                                    |
|                             |                               | Int 100% (0VAC), 5000ms      | B        |                                    |
|                             | EN60601-1-2<br>(240/480 VAC)  | Dip 100% (0VAC), 10ms        | A        |                                    |
|                             |                               | Dip 100% (0VAC), 20ms        | A        |                                    |
|                             |                               | Dip 60% (96/192VAC), 100ms   | A        |                                    |
| Dip 30% (168/336VAC), 500ms |                               | A                            |          |                                    |
| Int 100% (0VAC), 5000ms     |                               | B                            |          |                                    |
| SEMI F47-0706               | 480VAC nominal                |                              | A        |                                    |

## Safety approvals

| Safety agency  | Safety standard   | Notes & conditions  |
|--|---|---|
| Medical safety approvals are limited to the 48-200V models |   |   |
| CB report  | IEC62368-1 Ed 3   | Information Technology                                    |
|  | IEC60601-1 Ed 3 including Risk Management                           | Medical   |
| UL   | UL62368-1 Ed 3, CSA 62368-1:19 Ed 3                                 | Information Technology                                    |
|  | ANSI/AAMI ES60601-1: A1/A2: 2012, C1:2012, CSA C22.2 No. 60601-1:14 | Medical   |
| TUV  | EN62368-1 Ed 3  | Information Technology                                    |
|  | EN60601-1:2006/A12:2014   | Medical   |
| CE   | Meets all applicable directives                                     |   |
| UKCA   | Meets all applicable legislation                                    |   |
| Equipment protection class                                 | Class I   | See safety agency conditions of acceptability for details |
| Means of protection  |   |   |
| Primary to secondary                                       | 2 x MOPP (Means of Patient Protection)                              | IEC60601-1 Ed 3   |
| Primary to earth   | 1 x MOPP  |   |
| Secondary to earth   | N/A   |   |

## Application notes

### Input derating

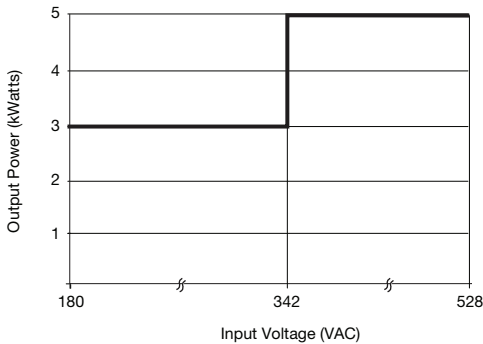

### Dielectric strength testing.

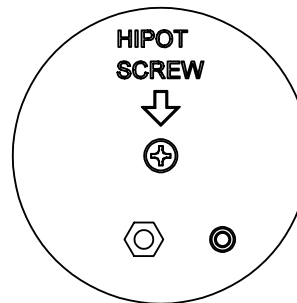

This product includes gas discharge tubes as part of the Surge Immunity counter-measures. This screw must be removed during dielectric strength testing in the end-equipment, to prevent flashover to Earth.

Maximum applied voltage:  
 Live and Neutral to Earth: 2121VDC  
 Input to Output: 2121VDC  
 Re-install the screw after testing.

### Output voltage programming

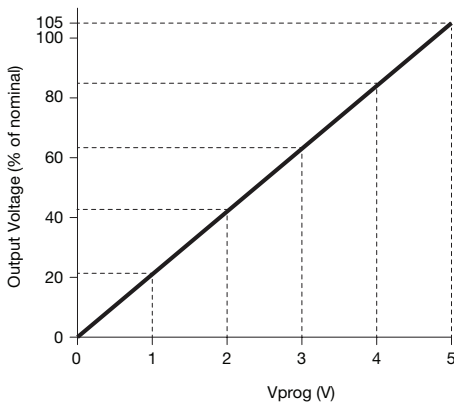

### Output current programming

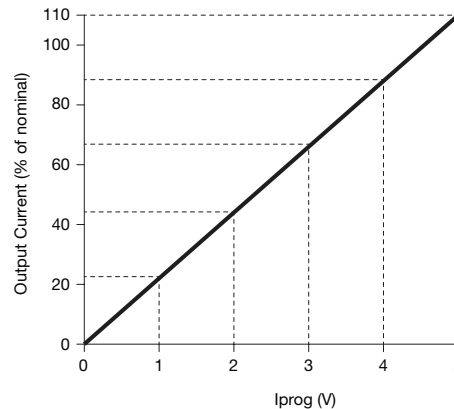

## Signal connections for 48-200V models

### Signal connections

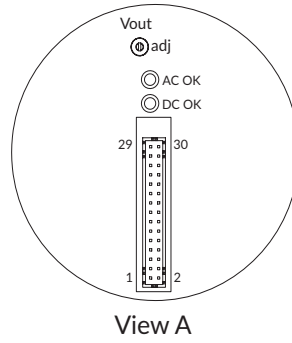

| Connector ID/<br>function | J1 control & monitoring<br>signals | Manufacturer: JST<br>PN: S30B PHDSS (LF) (SN) or equivalent  | User side, mating part: | Housing PN:<br>PHDR 30VS or equivalent<br>Contact: SPHD 002T P0.5 |
|---------------------------|------------------------------------|--|-------------------------|---|
| Pin                       | Function                           | Description  |                         |   |
| 1                         | DCOK Collector                     | Uncommitted opto-transistor. Conducting = Vout is within range. User configurable. Vce max: 15VDC. Ic max: 4mA. See circuit diagram on page 11   |                         |   |
| 2                         | DCOK Emitter                       |  |                         |   |
| 3                         | Remote on/off anode                | Uncommitted opto-diode. Supplied as Active=Inhibit. User configurable. Ifwd max: 8mA. See circuit diagram on page 11   |                         |   |
| 4                         | Remote on/off cathode              |  |                         |   |
| 5                         | A0                                 | I <sup>2</sup> C Device Address Bit (Internal 10kR pull-up to 3.3VDC)  |                         |   |
| 6                         | A1                                 |  |                         |   |
| 7                         | A2                                 |  |                         |   |
| 8                         | CANBus H                           | CANBus interface using CANopen protocol  |                         |   |
| 9                         | RS485 Y                            | Half-duplex: Non-inverting driver output & non-inverting receiver input. Full-duplex: Non-inverting driver output  |                         |   |
| 10                        | CANBus L                           | CANBus interface using CANopen protocol  |                         |   |
| 11                        | RS485 Z                            | Half-duplex: Inverting driver output & Inverting receiver input. Full-duplex: Inverting driver output  |                         |   |
| 12                        | SGND                               | Signal ground, common with the DC power output 0VDC terminal   |                         |   |
| 13                        | RS485 A                            | Full-duplex non-inverting receiver input   |                         |   |
| 14                        | I <sup>2</sup> C SDA               | I <sup>2</sup> C Data Line. 10kR internal pull-up to 3.3VDC  |                         |   |
| 15                        | RS485 B                            | Full-duplex inverting receiver input   |                         |   |
| 16                        | I <sup>2</sup> C SCL               | I <sup>2</sup> C Clock Line. 10kR internal pull-up to 3.3VDC   |                         |   |
| 17                        | Fan fail/temp warning              | Open Drain, referenced to SGND. Conducting = Normal operation. ID max: 30mA. Internal pull-up to 3.3VDC  |                         |   |
| 18                        | SYNC                               | Synchronises output start-up following application of AC input to units connected in parallel.<br>Do not use with units connected in series  |                         |   |
| 19                        | Vprog                              | 0-5VDC input to set Vout from 0-105% of nominal voltage.<br>Referenced to SGND (50kΩ internal resistance between Vprog and SGND)   |                         |   |
| 20                        | RS+                                | Positive Remote Sense (48-100VDC models)   |                         |   |
| 21                        | RS-                                | Negative Remote Sense (48-100VDC models)   |                         |   |
| 22                        | Iprog                              | 0 - 5VDC input to set current limit from 0 - 110% of rated current. Referenced to SGND (50.8kΩ internal resistance between Iprog and SGND)   |                         |   |
| 23                        | Current share                      | Linking the current share pins between identical voltage models, connected in parallel, will force the current to be shared. Maximum of 5 units in parallel. Sharing accuracy ±3% of a single unit current rating. |                         |   |
| 24                        | PMBUS_EN                           | Pull down to SGND to activate Vprog and Iprog analogue programming. Internal 10kR pull-up to 3.3VDC  |                         |   |
| 25                        | ACOK collector                     | Uncommitted opto-transistor. Not conducting = AC is out of range or a phase is lost. User configurable. Vce max: 15VDC. Ic max: 4mA  |                         |   |
| 26                        | ACOK emitter                       |  |                         |   |
| 27                        | 5V/2A housekeeping                 | This auxiliary output is constantly available when AC input is present   |                         |   |
| 28                        |                                    |  |                         |   |
| 29                        | Housekeeping 0V return             | Housekeeping 0V is also referenced to SGND   |                         |   |
| 30                        |                                    |  |                         |   |

## Signal connections for 400-800V models

### Signal connections

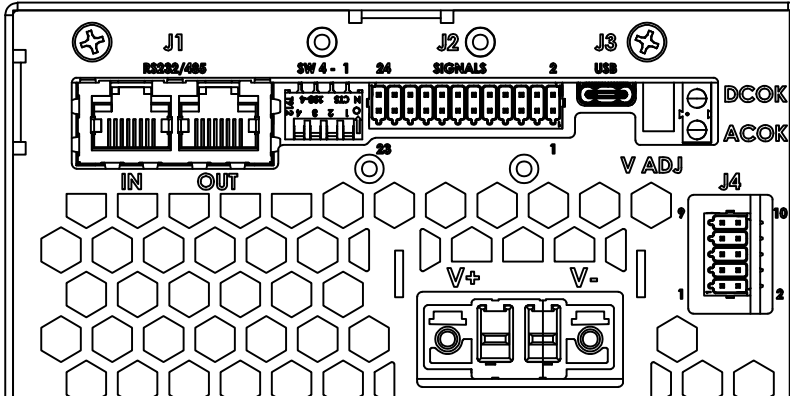

| Connector ID/<br>function | DC power output | Manufacturer: Phoenix contact PN: 1708491 | User side, mating part: | Connector PN: 1709157 |
|---------------------------|-----------------|---|-------------------------|-----------------------|
| Pin                       | Function        | Description                               |                         |                       |
| 1                         | +V DC output    | Legend moulded into mounting boss         |                         |                       |
| 2                         | 0V DC output    |   |                         |                       |

| Connector ID/<br>function | J1 isolated communications interface (RJ45) | Manufacturer: Molex PN: 432238128<br>Twin socket. Pins in parallel<br>Pins numbered right to left in customer view | User side, mating part: | FCC 68 plugs designed for flat telecoms flex |
|---------------------------|---|--|-------------------------|--|
| Pin                       | Function                                    | Description  |                         |  |
| 1                         | RS485 A                                     | Full-duplex non-inverting receiver input   |                         |  |
| 2                         | RS485 B                                     | Full-duplex inverting receiver input.  |                         |  |
| 3                         | RS232 TX                                    | RS232 Transmit line  |                         |  |
| 4                         | Iso Gnd                                     | Signal ground, isolated from DC power output   |                         |  |
| 5                         | Iso Gnd                                     |  |                         |  |
| 6                         | RS232 RX                                    | RS232 Receive line   |                         |  |
| 7                         | RS485 Z                                     | Half-duplex: Inverting driver output & Inverting receiver input, Full-duplex: Inverting driver output              |                         |  |
| 8                         | RS485 Y                                     | Half-duplex: Non-inverting driver output & non-inverting receiver input, Full-duplex: Non-inverting driver output  |                         |  |

| Connector ID/<br>function | J2 isolated communications interface 24 pin | Manufacturer: Phoenix contact<br>PN: 1844824  | User side, mating part: | Connector PN: 1844675,<br>crimp-free assembly. Wire gauge:<br>0.14 - 0.5mm <sup>2</sup> , 26-20awg |
|---------------------------|---|---|-------------------------|--|
| Pin                       | Function                                    | Description   |                         |  |
| 1                         | DCOK collector                              | Uncommitted opto-transistor. Conducting = Vout is within range.<br>User configurable. Vce max: 15VDC. Ic max: 4mA. See circuit diagram on page 11                 |                         |  |
| 2                         | DCOK emitter                                |   |                         |  |
| 3                         | Remote on/off anode                         | Uncommitted opto-diode. Supplied as Active = Inhibit. User configurable. Can be used in conjunction with the Safety Interlock.<br>See circuit diagram on page 11. |                         |  |
| 4                         | Remote on/off cathode                       |   |                         |  |
| 5                         | AC OK collector                             | Uncommitted opto-transistor. Not conducting = AC is out of range or a phase is lost. User configurable.<br>Vce max: 15VDC. Ic max: 4mA                            |                         |  |
| 6                         | AC OK emitter                               |   |                         |  |
| 7                         | Address A0                                  | I <sup>2</sup> C Device Address Bit (Internal 10kR pull-up to 3.3VDC)   |                         |  |
| 8                         | Address A1                                  |   |                         |  |
| 9                         | Address A2                                  |   |                         |  |
| 10                        | PMBUS_EN                                    | Pull-down to Iso Gnd to activate Vprog and Iprog analogue programming. Internal 10kR pull-up to 3.3VDC.   |                         |  |
| 11                        | I <sup>2</sup> C SDA                        | I <sup>2</sup> C Data Line. 10kR internal pull-up to 3.3VDC.  |                         |  |
| 12                        | I <sup>2</sup> C SCL                        | I <sup>2</sup> C Clock Line. 10kR internal pull-up to 3.3VDC  |                         |  |
| 13                        | Fan fail/temp warning                       | Open Drain, referenced to Iso Gnd. Conducting = Normal operation. I <sub>D</sub> max: 30mA. Internal pull-up to 3.3VDC  |                         |  |

Continues on next page

## Signals, controls & connectors

| Connector ID/<br>function | J2 isolated communications<br>interface 24 pin | Manufacturer: Phoenix contact<br>PN: 1844824   | User side, mating part: | Connector PN: 1844675,<br>crimp-free assembly |
|---------------------------|--|--|-------------------------|---|
| Pin                       | Function                                       | Description  |                         |   |
| 14                        | Iso ground                                     | Signal ground, isolated from DC power output   |                         |   |
| 15                        | Iprog  | 0-5VDC input to set current limit from 0-110% of rated current. Referenced to Iso Gnd.                   |                         |   |
| 16                        | Vprog  | 0-5VDC input to set current limit from 0-105% of nominal voltage. Referenced to Iso Gnd.                 |                         |   |
| 17                        | CANBus H                                       | CANBus interface using CANopen protocol  |                         |   |
| 18                        | CANBus L                                       |  |                         |   |
| 19                        | 5V/2A housekeeping                             | This auxiliary output is constantly available when AC input is present. Referenced to Iso Gnd.           |                         |   |
| 20                        | 5V/2A housekeeping                             |  |                         |   |
| 21                        | Iso ground                                     | Signal ground, isolated from DC power output   |                         |   |
| 22                        | Iso ground                                     |  |                         |   |
| 23                        | Interlock input A                              | Uncommitted opto-diode Anode (two diodes in series). Conducting = Safe to activate output. Vin: 5-28VDC. |                         |   |
| 24                        | Interlock input K                              | Uncommitted opto diode Cathode.  |                         |   |

| Connector ID/<br>function    | J3: USB-C configuration port | User side, mating part:            | Standard USB-C jack |
|------------------------------|------------------------------|------------------------------------|---------------------|
| J3: USB-C configuration port |                              |                                    |                     |
| Pin                          | Function                     | Description                        |                     |
| 1                            | USB serial data interface.   | Alternative port for SCPI control. |                     |

| Connector ID/<br>function | J4: Non-isolated control interface. 10 pin | Manufacturer: Phoenix contact.<br>PN: 1844756  | User side, mating part: | Connector PN: 1844604, crimp-free<br>assembly. Wire gauge:<br>0.14 - 0.5mm <sup>2</sup> , 26 - 20awg |
|---------------------------|--|--|-------------------------|--|
| Pin                       | Function                                   | Description  |                         |  |
| 1                         | SGND                                       | Signal ground, common with DC power output 0V terminal   |                         |  |
| 2                         |  |  |                         |  |
| 3                         | Not used                                   |  |                         |  |
| 4                         |  |  |                         |  |
| 5                         | Sync                                       | Synchronises output start-up following application of AC input to units connected in parallel. Do not use with units connected in series   |                         |  |
| 6                         |  |  |                         |  |
| 7                         | Not used                                   |  |                         |  |
| 8                         |  |  |                         |  |
| 9                         | Current Share                              | Linking the current share pins between identical voltage models, connected in parallel, will force the current to be shared. Maximum of 5 units in parallel. Sharing accuracy $\pm 3\%$ of a single unit current rating. |                         |  |
| 10                        |  |  |                         |  |

| Connector ID/<br>function | DIP switches                          | Counting 1 to 4 from right to left                    |
|---------------------------|---------------------------------------|---|
| Pin                       | Function                              | Description   |
| 1                         | CANBus 120R termination resistor      | Close switch to apply 120R between CAN H and CAN L.   |
| 2                         | Half-Duplex 120R termination resistor | Close switch to apply 120R resistor between RS485 A&B |
| 3                         | Full-Duplex 120R termination resistor | Close switch to apply 120R resistor between RS485 Y&Z |
| 4                         | RS485 Half-Full Duplex select         | Close switch to select Full Duplex.                   |

## Signals, controls & connectors

Suggested Application Circuits for 48-200V models. Functions are described in their default configuration.

### DC OK

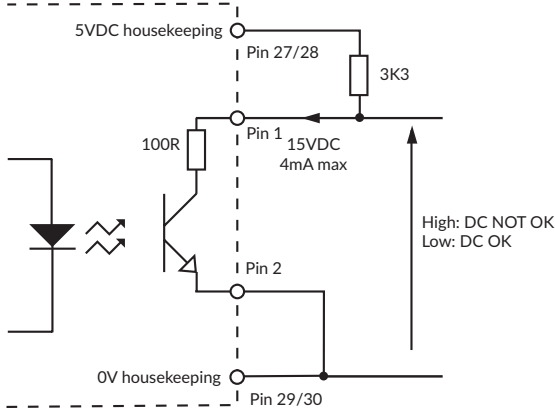

### AC OK

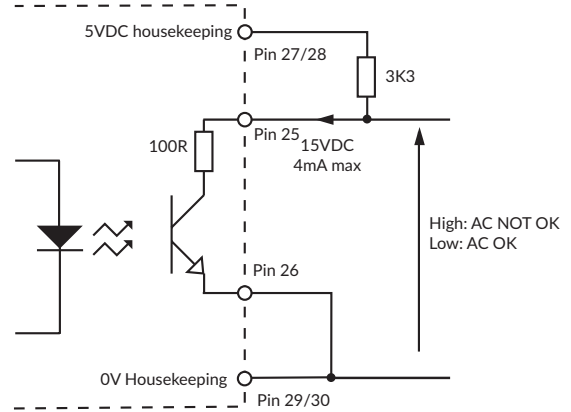

### Fan fail/temperature warning

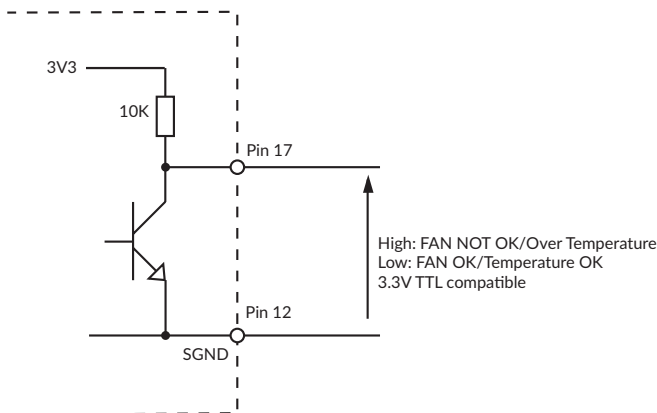

### Remote on/off (inhibit)

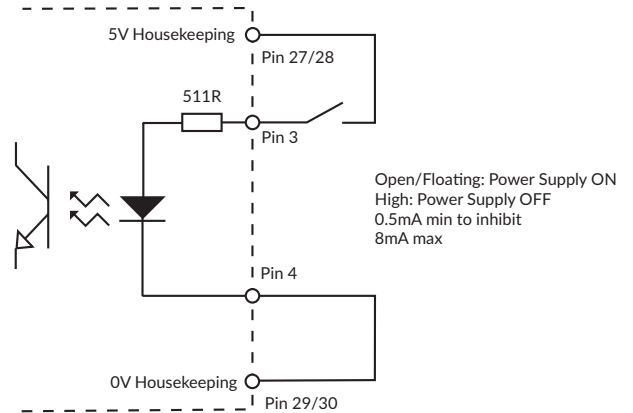

### Current share: 48 - 100V models

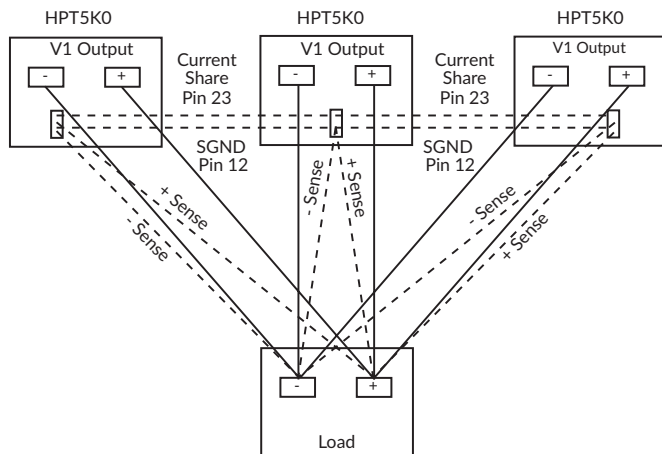

#### Current share notes:

1. Up to five HPT5K0 units may be connected in parallel.
2. The SYNC pins may also be linked between units. See function description.
3. Both SYNC and Current Share require SGND to be linked.
4. Remote Sense is fitted to 48-100VDC models.

## Signals, controls & connectors

Suggested application circuits for 400-800VDC models. Functions are described in their default configuration.

### DC OK

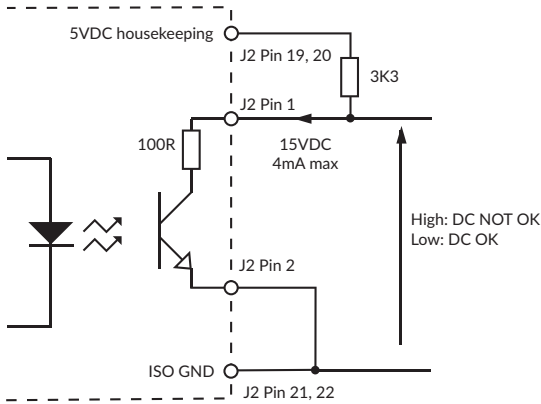

### AC OK

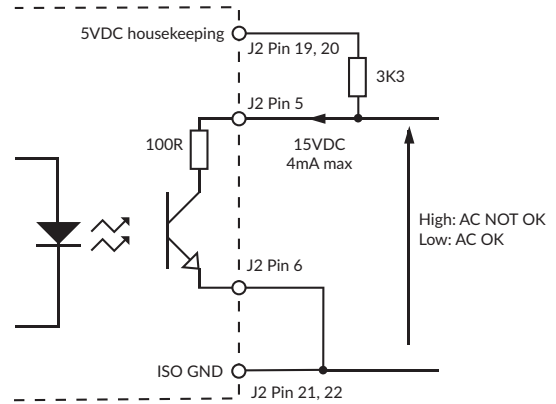

### Fan fail/temperature warning

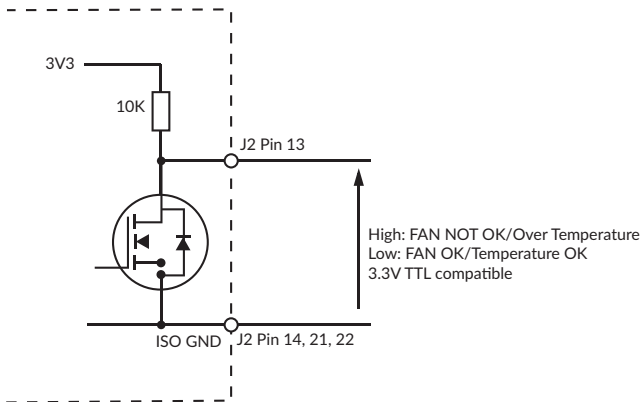

### Remote on/off (inhibit)

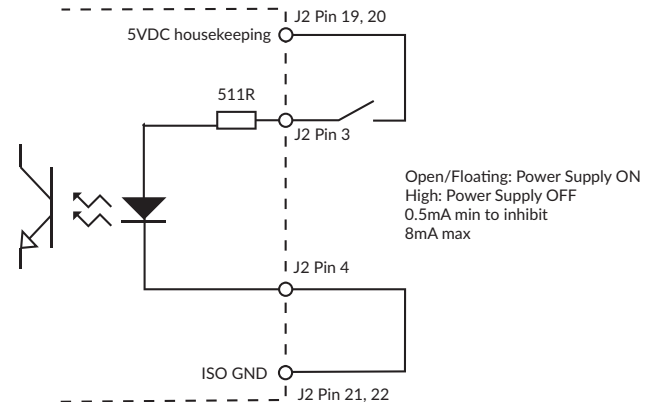

### Current share: 400 - 800VDC models

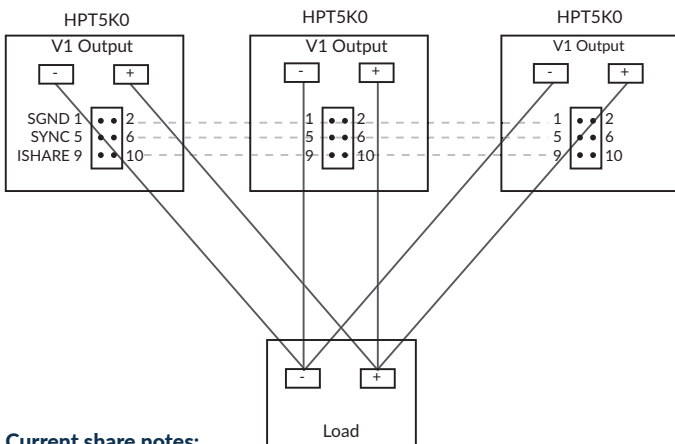

#### Current share notes:

- Up to five HPT5K0 units may be connected in parallel.
- The SYNC pins may also be linked between units. See function description.
- Both SYNC and Current Share require SGND to be linked. On 400VDC & 800VDC models, SGND must only be used for these two functions.
- Remote Sense is fitted to 48VDC-100VDC models.

### Safety interlock

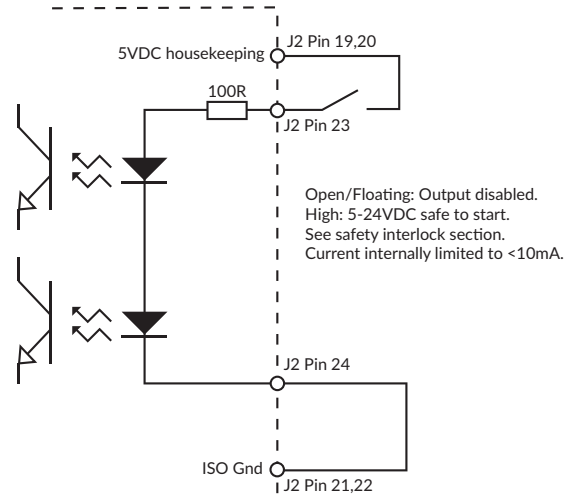

## LED signals

| Conditions   | LED State                                   |                                | Signals  |                                   |                            |                                      |
|--|---|--------------------------------|----------|-----------------------------------|----------------------------|--------------------------------------|
|  | AC OK                                       | DC OK                          | AC OK    | DC OK                             | FAN_FAIL/TEMP              | Remote on/off inhibit <sup>(3)</sup> |
| AC input OK  | ON  | ON <sup>(2)</sup>              | Active   | Active                            | Active Low                 | Inactive                             |
| AC input below control system startup voltage  | OFF   | OFF                            | Inactive | Inactive                          | Inactive                   | Don't care                           |
| AC present but out of range, PFC failure, missing phase or internal communications fault | Blink 0.2s on, 0.2s off                     | OFF                            | Inactive | Inactive                          | Active Low                 | Don't care                           |
| Output over voltage protection   | ON  | OFF                            | Active   | Inactive                          | Active Low                 | Inactive                             |
| Output over current protection (constant current mode)                                   | ON  | Blink 0.2s on, 0.2s off        | Active   | Active or Inactive <sup>(2)</sup> | Active Low                 | Inactive                             |
| Fan failure/thermal shutdown   | ON  | OFF                            | Active   | Inactive                          | Active High <sup>(1)</sup> | Inactive                             |
| Safety interlock input is open circuit <sup>(4)</sup>                                    | ON  | Double blink 0.2s on, 1.0s off | Active   | Inactive                          | Active Low                 | Inactive                             |
| Remote on/off unit disabled  | ON  | Blink 1.0s on, 1.0s off.       | Active   | Inactive                          | Active Low                 | Active                               |
| Digital communications on/off unit disabled  | ON  | Blink 1.0s on, 1.0s off.       | Active   | Inactive                          | Active Low                 | Inactive                             |
| Bootloader firmware update in progress   | Both LEDs blink together: 1.0s on, 1.0s off |                                | Inactive | Inactive                          | Inactive                   | Don't care                           |
| Bootloader update complete   | Blink 0.5s on, 0.5s off                     | Blink 1.0s on, 1.0s off        | Inactive | Inactive                          | Inactive                   | Don't care                           |

### Notes:

- In case of fan failure and/or over-temperature, FAN FAIL/TEMP warning signal will be set 10s before output shutdown.
- DC OK LED is on if output voltage  $\geq$  VOUT\_UV\_FAULT\_LIMIT parameter.
- Remote ON/OFF factory setting is: Active = Inhibit operation. User configurable.
- Indication of Safety Interlock status takes precedence over status of ON/OFF controls.

## Mechanical details

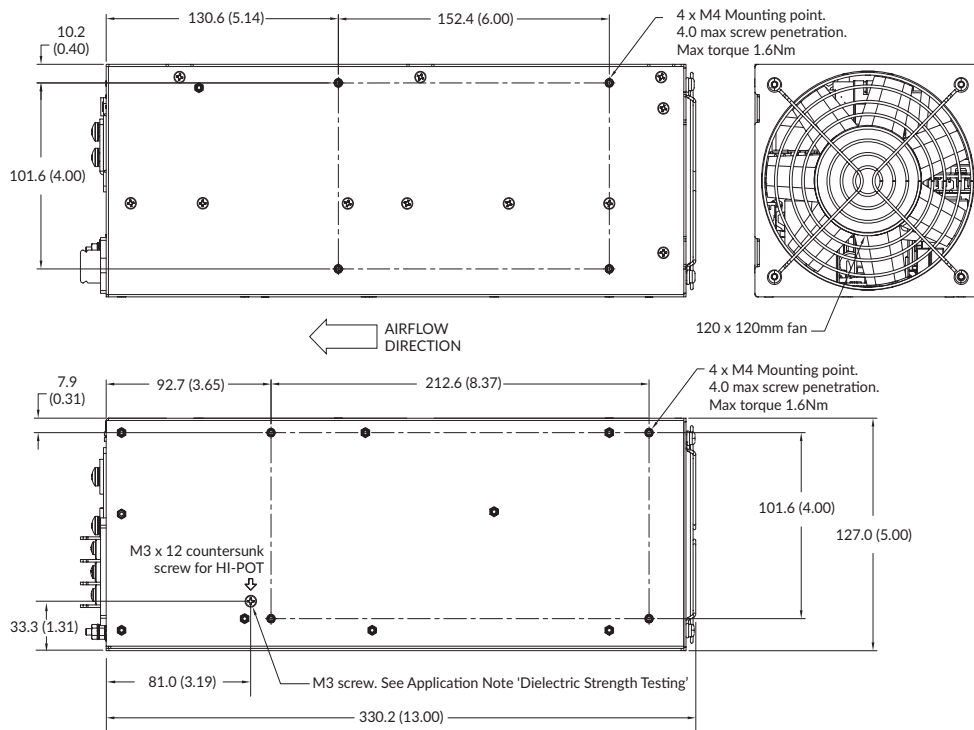

### Notes:

- All dimensions are in mm (inches).
- Weight 5.7kg (12.5lb)

# HPT5K0 series

## Mechanical details

48-200VDC end view

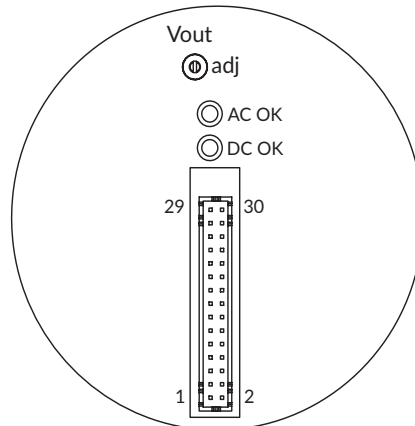
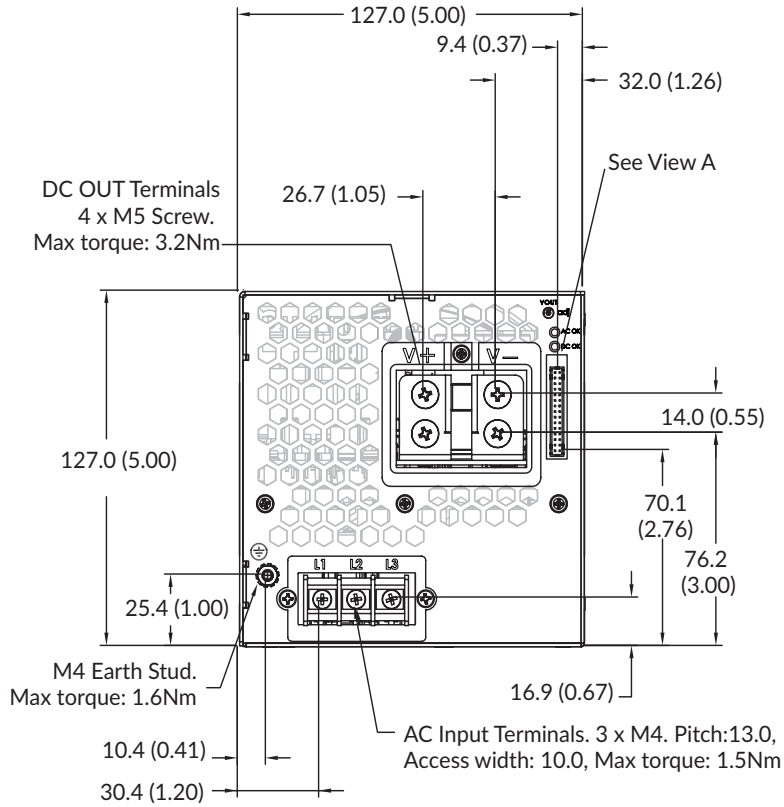

View A

## Mechanical details

### 400-800VDC end view

Locking screws are captive in plug. Max torque 0.7Nm.

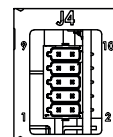
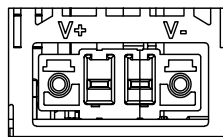
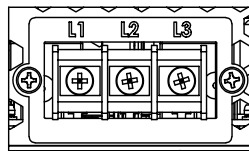
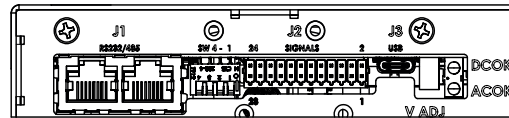
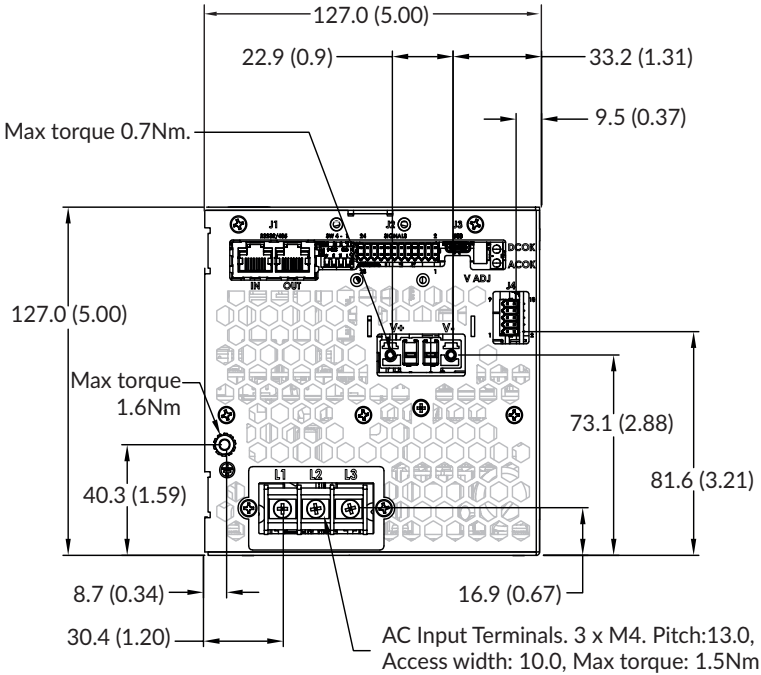

### Accessory Bracket

An accessory bracket is included with the product. This provides a securing point for the J1-J4 signal looms and prevents inadvertent contact with the power output connector terminal screws.

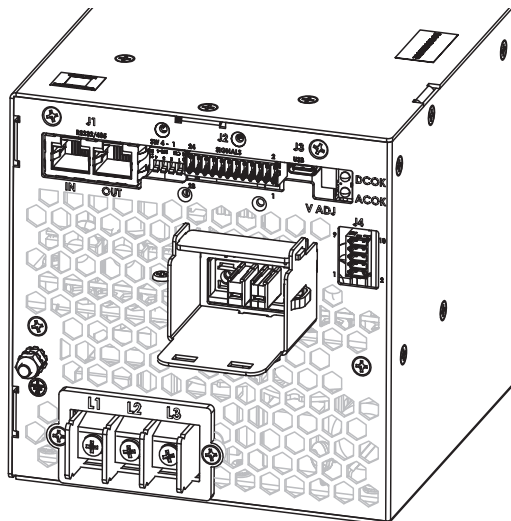

Specifications subject to change without notice.