

— SHP650 Series

650W FAN COOLED

AC-DC POWER SUPPLIES

The SHP650 AC-DC power supply provides up to 650W of output power in three mechanical packages to provide installation flexibility in a range of semiconductor, industrial and analytical instrumentation applications.

Packaged in a compact 8" x 4" x 2.5" and carrying IEC62368 family safety approvals, the SHP650 has a main output with voltages from 12-48VDC and two peripheral outputs providing a 12VDC fan supply and a 5VDC standby supply which can be utilized with the signals and control features of the unit to provide AC Input loss detection and remote on/off control.

Multiple units can be used in parallel via the current share facility, providing higher power solutions. Inherently low earth leakage current and conducted EMC compliance to Class B simplify higher power system design.



Applications



Dimensions

8.00" x 4.00" x 2.5" (203.2 x 101.6 x 63.5 mm)

Features

- Output voltages 12 to 48VDC
- Rugged industrial construction
- End fan, top fan and U channel mechanical options
- IEC60950 and SEMI F47 compliant
- Operating temperature range from -40°C to +70°C
- Peripheral 12VDC fan supply and 5V standby
- AC OK, remote On/Off and active current share
- Load dependent variable fan speed
- Overcurrent, overvoltage and overtemperature protection
- 3 year warranty

Models & Ratings

Model Number ⁽¹⁾	Output Voltage V1	Output Current V1	Fan Supply V2 ⁽⁴⁾	Standby Supply V3	Output Power ⁽³⁾
SHP650PS12-EF	12V	50.0A	12V/0.5A	5V/0.2A	607W
SHP650PS15-EF	15V	40.0A	12V/0.5A	5V/0.2A	607W
SHP650PS24-EF	24V	27.0A	12V/0.5A	5V/0.2A	655W
SHP650PS28-EF	28V	23.0A	12V/0.5A	5V/0.2A	655W
SHP650PS36-EF	36V	18.0A	12V/0.5A	5V/0.2A	655W
SHP650PS48-EF	48V	13.5A	12V/0.5A	5V/0.2A	655W

Notes:

1. For top fan version replace suffix '-EF'-TF', e.g. SHP650PS12-TF.
2. For U Channel version remove suffix '-EF' e.g. SHP650PS12.

3. U Channel models require a minimum of 5.5m/s airflow from the system.
4. Not available for '-TF' and '-EF' models as used by integral fan.

— SHP650 Series

Summary

Characteristic	Minimum	Typical	Maximum	Units	Notes & Conditions
Input Voltage	85	115/230	264	VAC	Derate output power 10% <90VAC, see Fig. 1
Efficiency		84		%	See Models & Ratings
Operating Temperature	-20		+70	°C	Derate linearly from 100% load at 50°C to 50% load at 70°C
EMC	EN55022 Level A Conducted & Radiated				
Safety Approvals	UL62368-1, CSA C22.2 No 62368-1-14, EN62368-1, IEC62368-1:2014, CE (Meets all applicable directives), UKCA (Meets all applicable legislation)				
Weight		3.85 (1.75)		lb (kg)	

Input

Characteristic	Minimum	Typical	Maximum	Units	Notes & Conditions
Input Voltage	85	115/230	264	VAC	Derate output power 10% <90VAC, see Fig. 1
Input Frequency	47	50/60	63	Hz	Agency approval, 47-63 Hz
Power Factor	0.9				
Input Current - No Load		0.15/0.3		A	115/230VAC
Input Current - Full Load		6.5/3.2		A	115/230VAC
Inrush Current			40	A	230 VAC cold start, 25°C
Earth Leakage Current		0.3/0.5	0.75	mA	115/230 VAC/50 Hz (Typ.), 264 VAC/60 Hz (Max.)
Input Protection	T16 A / 250V internal in-line fuse				

Input Derating Curve

Figure 1

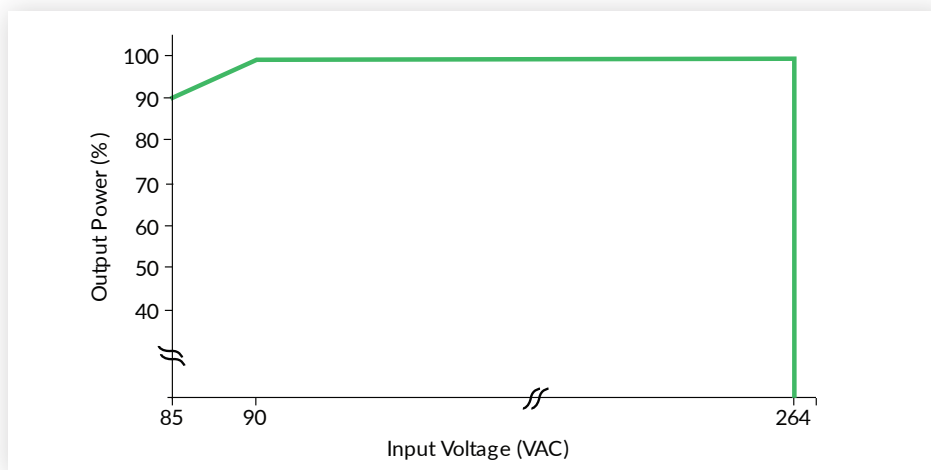

Output

Characteristic	Minimum	Typical	Maximum	Units	Notes & Conditions
Output Voltage - V1	12		48	VDC	See Models & Ratings table
Initial Set Accuracy		±1		%	V1, 50% load, 115/230VAC
		±5		%	V3, 50% load, 115/230VAC
Output Voltage Adjustment			±10	%	V1 only. See Mechanical Details
Minimum Load	No minimum load required				
Start Up Delay		0.5		s	230VAC full load
Hold Up Time	20			ms	
Drift			±0.2	%	After 20 min warm up
Line Regulation			±0.5	%	
Load Regulation			±1	%	V1, 0-100% load
			±5	%	V3, 0-100% load
Transient Response			4	%	Recovery within 1% in less than 500µs for a 50-75% and 75-50% load step
Ripple & Noise			1	% pk-pk	V1, 20MHz bandwidth
Overvoltage Protection	115		140	%	Vnom DC. Output 1 only, recycle input to reset
Overtemperature Protection	Auto reset				
Overload Protection	110		145	% I nom	Output 1 only, auto reset. See fig 2.
Short Circuit Protection	Auto recovery, hiccup mode				
Temperature Coefficient			0.02	%/°C	

Output Overload Characteristic

Figure 2
Typical V1 Overload Characteristic
 (SHP650PS12 shown)

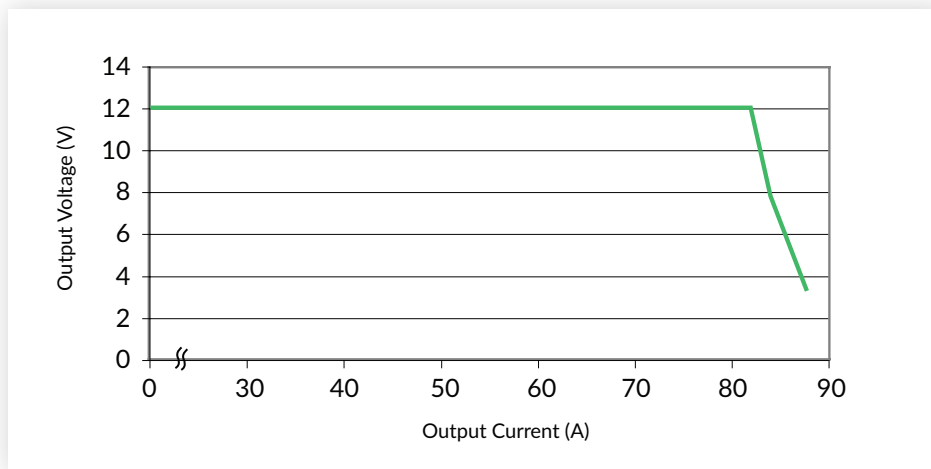

— SHP650 Series

General

Characteristic	Minimum	Typical	Maximum	Units	Notes & Conditions
Efficiency		84		%	See Fig. 3 & 4
Isolation: Input to Output Input to Ground Output to Ground	3000			VAC	
	1500			VAC	
	500			VDC	
Switching Frequency		70		kHz	PFC converter
		200			Main converter
		130			Standby
Power Density			8.2	W/in ³	
Mean Time Between Failure		260		khrs	MIL-HDBK-217F, 25°C GB
Weight			2.8 (1.25)	lb (kg)	See Mechanical Details

Efficiency Graphs

Efficiency vs Load

Figure 3
SHP650PS12

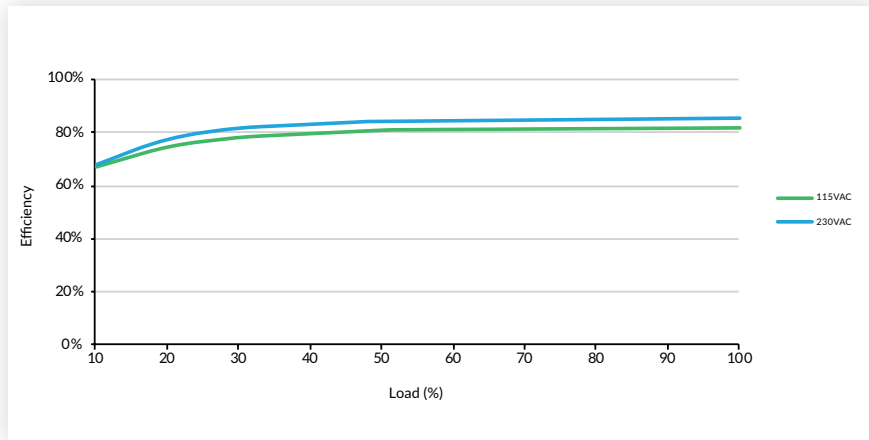
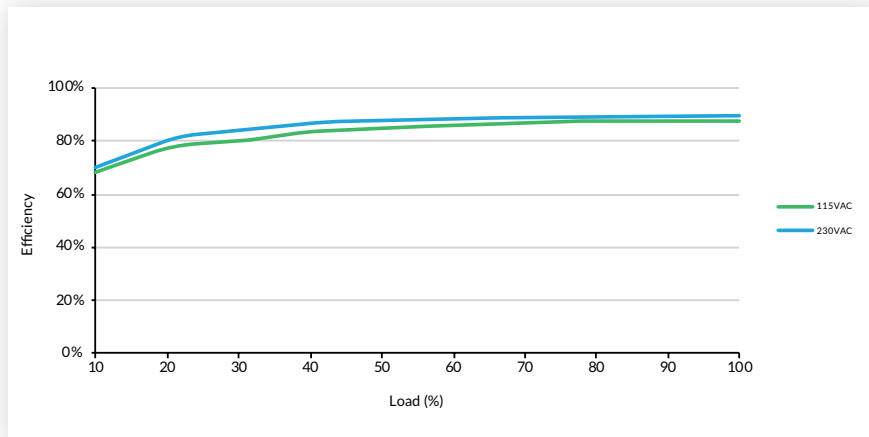

Figure 4
SHP650PS48



Signals & Controls

	Function
Remote Sense	Compensates for 0.5V total voltage drop
AC OK/Power Fail	Open collector referenced to negative sense, transistor normally off when AC is good (see fig. 5 & 8) AC OK: Provides $\geq 5\text{ms}$ warning of loss of output from AC failure
Remote On/Off (Inhibit/Enable)	Uncommitted isolated optocoupler diode, powered diode inhibits both V1 & V2 (fan supply) (see fig.6 & 9)
Current Share	When more than one unit (with the same output voltage) is used in parallel to increase output current, the current share pins 5/6 of one unit should be connected to pins 5/6 of the other unit(s). This will force the current to share between the outputs. Similarly pins 2/4 of each unit should also be connected as a ground reference. Units share current within 10% of each other at full load. See fig 7
Standby Supply V3	Isolated 5V/0.2A supply, always present when AC supplied

AC OK/Power Fail
Figure 5

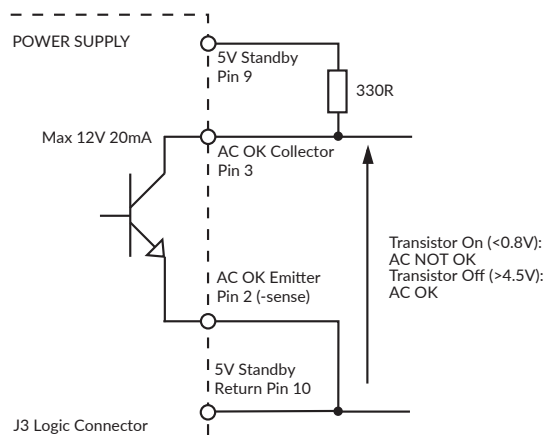

Remote On/Off (Inhibit)
Figure 6

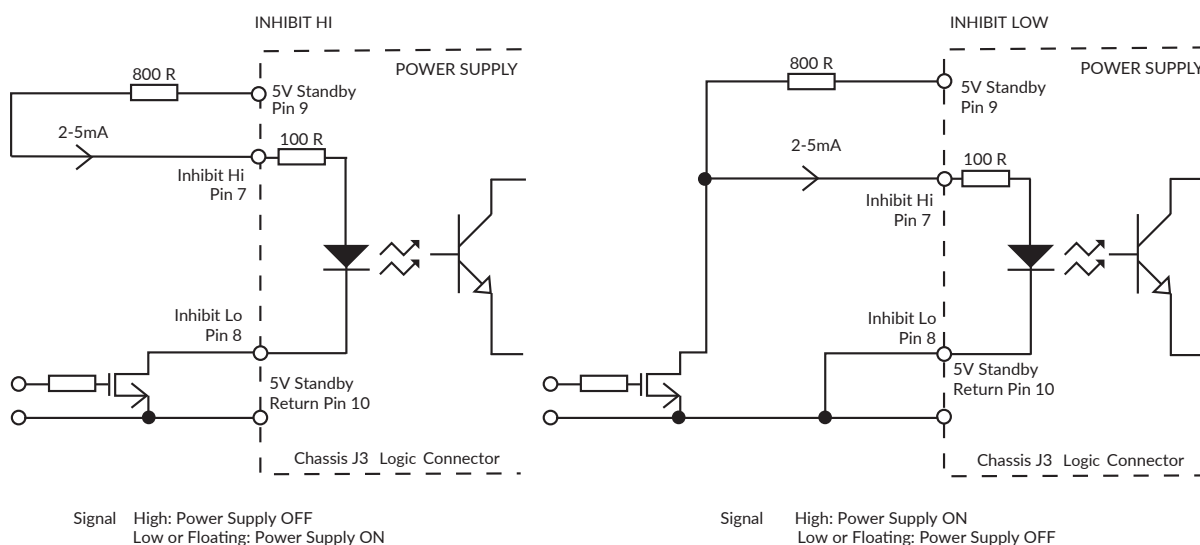

— SHP650 Series

Signals & Controls

Parallel Load & Current Share Connection Example

Figure 7

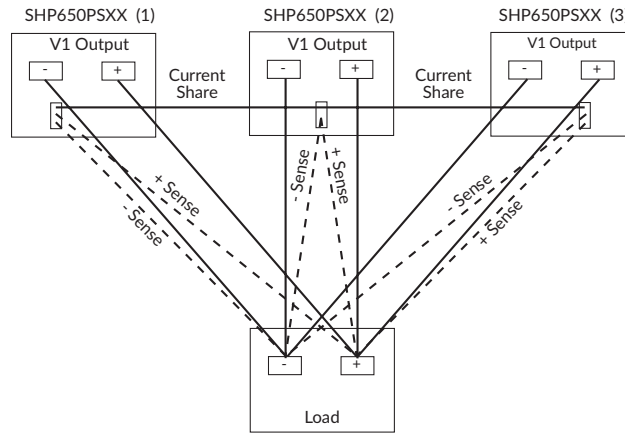

Parallel AC OK Connection

Figure 8

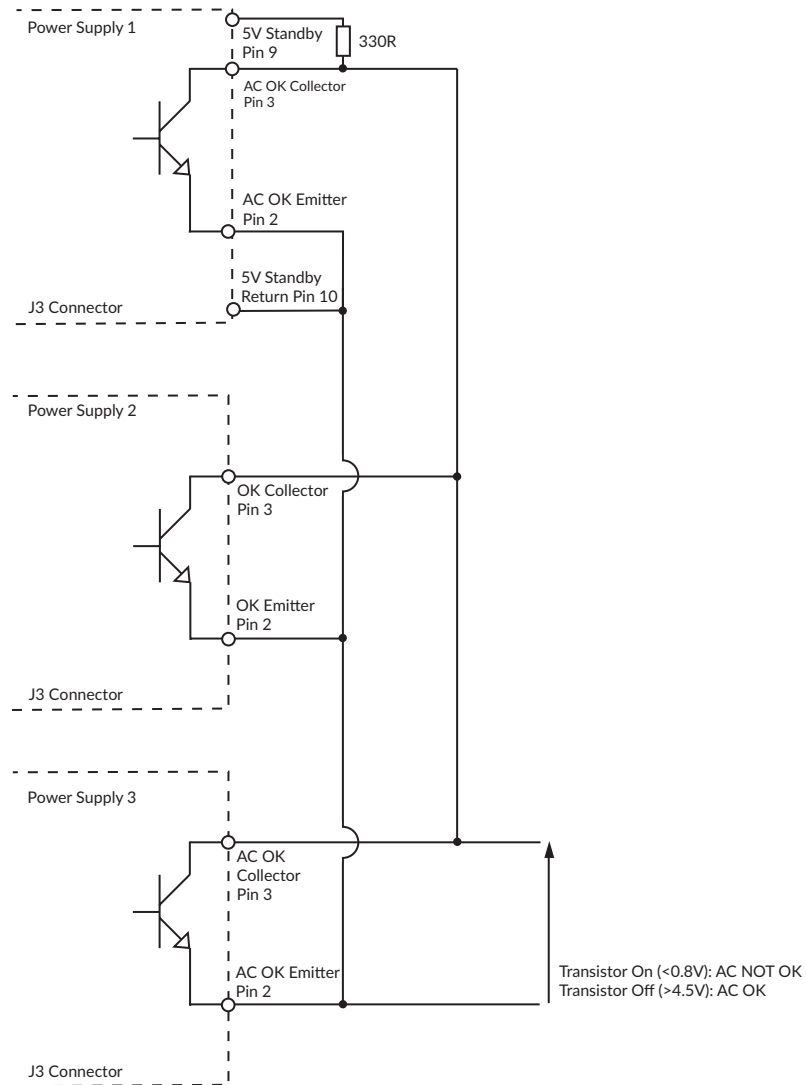

Signals & Controls

Parallel Remote Inhibit Connection

Figure 9

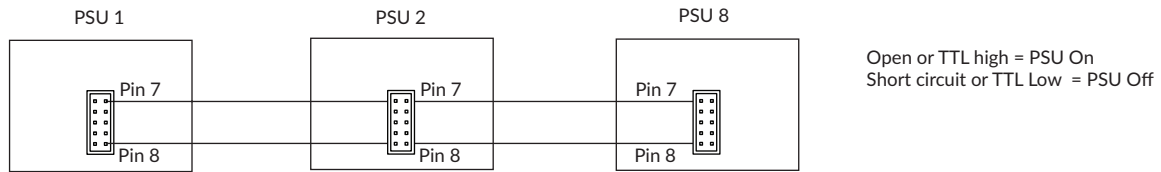

Environmental

Characteristic	Minimum	Typical	Maximum	Units	Notes & Conditions
Operating Temperature	-40		+70	°C	Derate linearly from +50°C at 2.5%/°C to 50% at +70°C, -40°C start up. See derating curve, fig. 10
Storage Temperature	-40		+85	°C	Some specification parameters maybe exceeded until after 20 minute warm up period
Cooling	Integral variable speed fan load dependant. See fig 11				
Operating Humidity			95	%RH	Non-condensing
Operating Altitude			3000	m	
Shock	30g pk, half sine, 6 axes EN60068-2-27, -2-47				
Vibration	Single axis 10-500 Hz at 2g x 10 sweeps				

Temperature Derating Curve

Figure 10

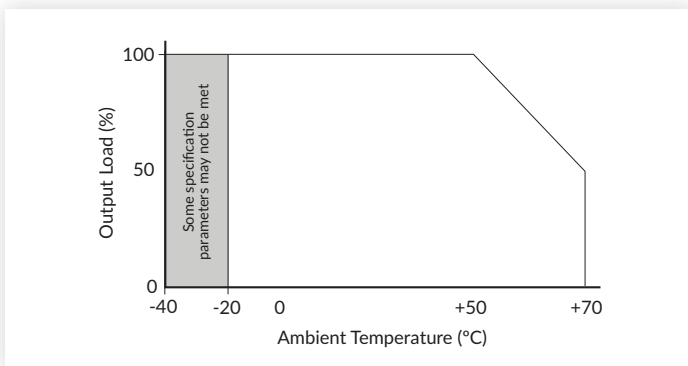

Fan Speed Control

Figure 11

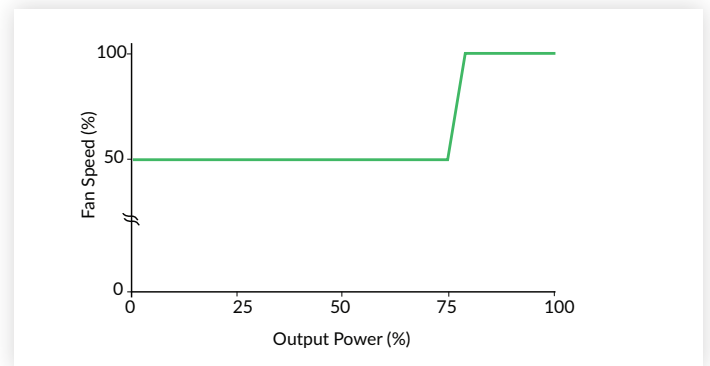

EMC: Emissions

Phenomenon	Standard	Test Level	Notes & Conditions
Conducted	EN55032	Class B	
Radiated	EN55032	Class A	
Voltage Fluctuations	EN61000-3-3		

EMC: Immunity

Phenomenon	Standard	Test Level	Criteria	Notes & Conditions
Low Voltage PSU EMC	EN61204-3	High severity level	as below	
Harmonic Current	EN61000-3-2	Class A		
		Class C		For loads $\geq 10\%$
ESD	EN61000-4-2	3	A	
Radiated	EN61000-4-3	3	A	
EFT/Burst	EN61000-4-4	3	A	
Surge	EN61000-4-5	Installation class 3	A	
Conducted	EN61000-4-6	3	A	
Dips and Interruptions	EN61000-4-11	Dip 30% 10ms	A	
		Dip 60% 100ms	B	
		Dip 100% 5000ms	B	
	SEMI F47			Compliant

Safety Approvals

Certification	Standard	Notes & Conditions
CB	IEC60950-1:2005 Ed 2 / IEC62368-1:2014	Information Technology
UL	UL 62368-1 & CAN/CSA C22.2 No. 62368-1-14	Information Technology
TUV	EN62368-1, SEMI F47	Information Technology
CE	Meets all applicable directives	
UKCA	Meets all applicable legislation	
Equipment Protection Class	Standard	Notes & Conditions
Class I	IEC60950-1:2005 Ed 2 / IEC62368-1:2014	See safety agency conditions of acceptability for details

— SHP650 Series

Mechanical Details

End Fan (-EF)

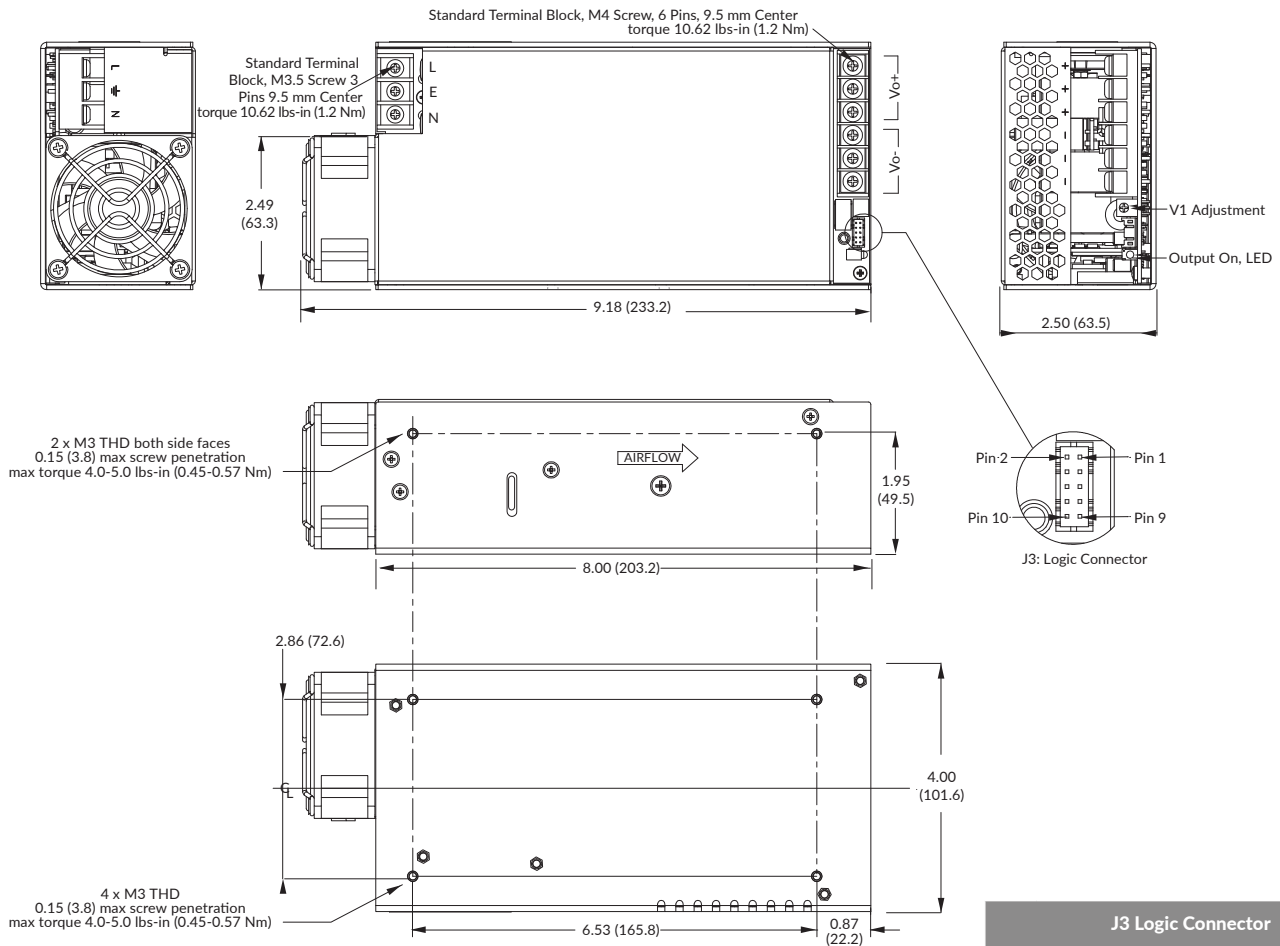

J3 Logic Connector (JST B10B-PHDSS)	
Pin	Description
1	+ Sense
2	- Sense
3	AC OK/Power Fail
4	- Sense
5	Current Share
6	Current Share
7	+ Inhibit
8	- Inhibit
9	+5V Standby (V3)
10	5V Standby Return (V3)

Mating connector CN2: Manufacturer :JST
Housing: PHDR-24VS Contacts: SPHD-002T-P0.5 (28-24 AWG)

Notes:

1. Dimensions shown in inches (mm).
2. Weight: 2.8lb (1.27kg).

3. J3 Mating plug: JST part no. PHDR-10VS, contact: 26-22 AWG JST part no. SPHD-001T-P0.5.

— SHP650 Series

Mechanical Details

Top Fan (-TF)

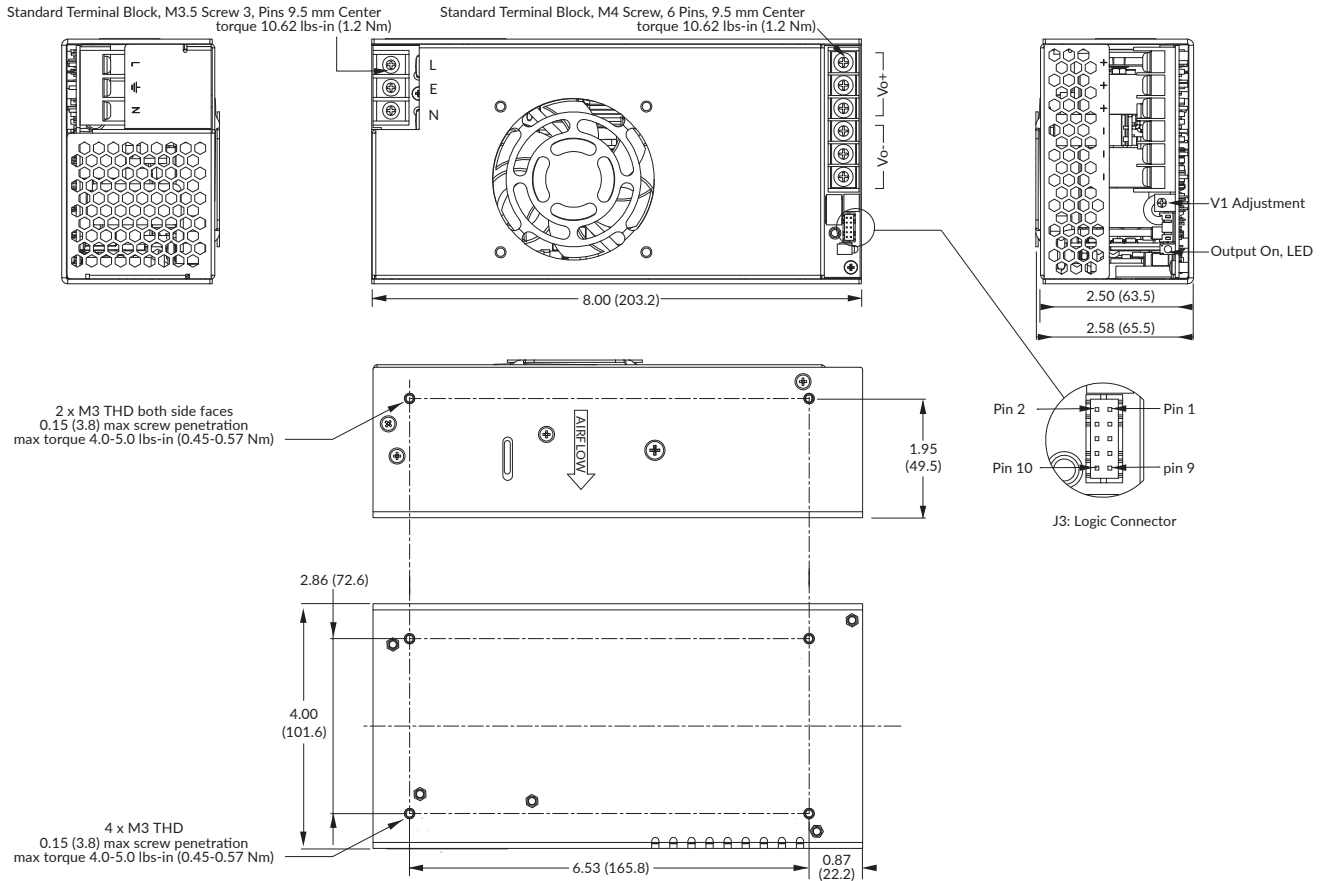

J3 Logic Connector (JST B10B-PHDSS)	
Pin	Description
1	+ Sense
2	- Sense
3	AC OK/Power Fail
4	- Sense
5	Current Share
6	Current Share
7	+ Inhibit
8	- Inhibit
9	+5V Standby (V3)
10	5V Standby Return (V3)

Notes:

1. Dimensions shown in inches (mm).
2. Weight: 2.6lb (1.2kg).

3. J3 Mating plug: JST part no. PHDR-10VS, contact: 26-22 AWG JST part no. SPHD-001T-P0.5.

— SHP650 Series

Mechanical Details

U Channel (no suffix)

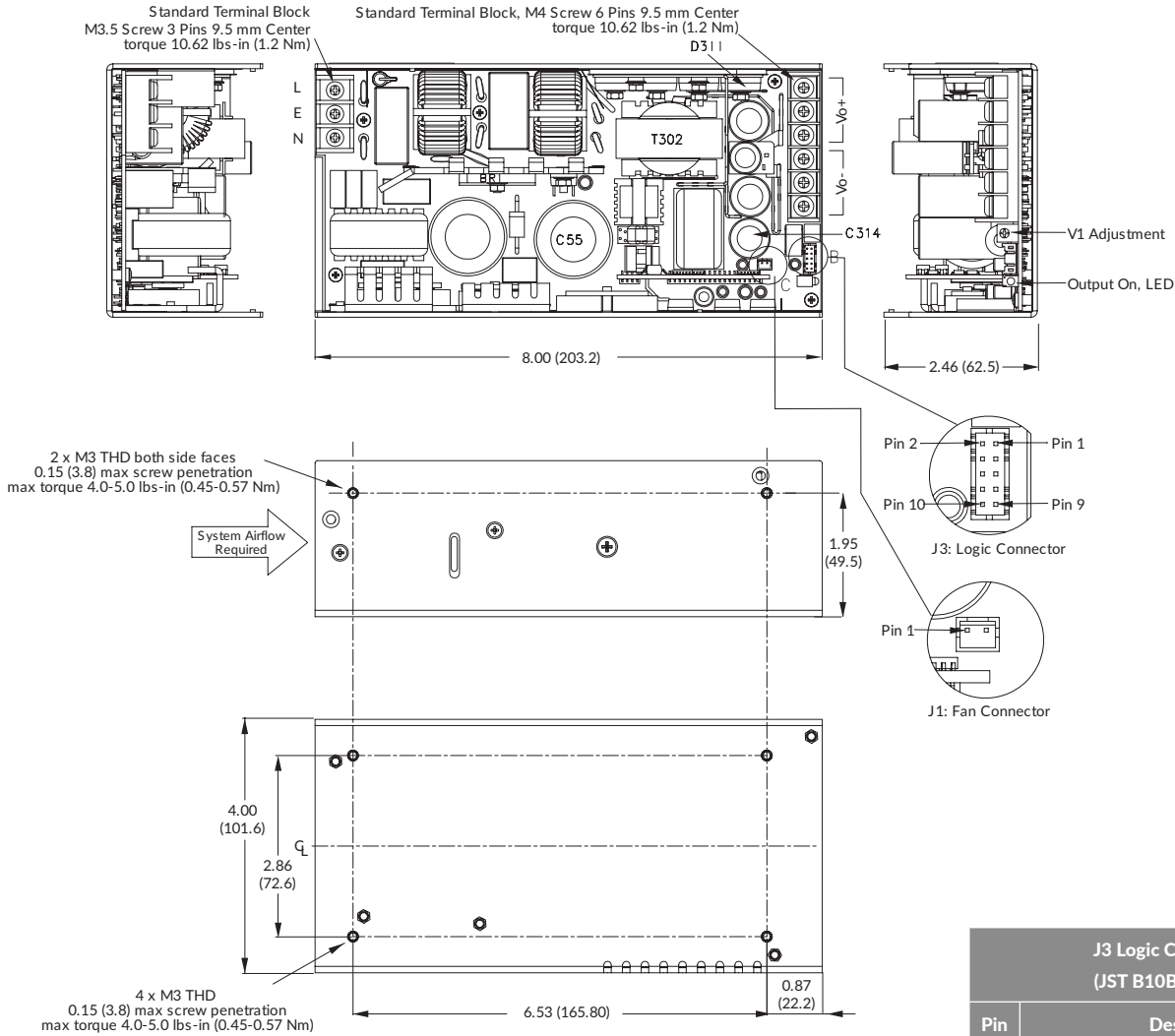

J3 Logic Connector (JST B10B-PHDSS)	
Pin	Description
1	+ Sense
2	- Sense
3	AC OK/Power Fail
4	- Sense
5	Current Share
6	Current Share
7	+ Inhibit
8	- Inhibit
9	+5V Standby (V3)
10	5V Standby Return (V3)

J1 Logic Connector JST B2B-PH-KL (LF) (SN)	
Pin	Description
1	+V
2	NC
3	-V

Notes:

1. Dimensions shown in inches (mm).
2. Weight: 2.4 lb (1.1 kg).
3. Requires system airflow, see thermal considerations.

4. J3 Mating plug: JST part no. PHR-2, contact: JST part no. SPH-002T-P0.5S.
5. J3 Mating plug: JST part no. PHDR-10VS, contact: 26-22 AWG JST part no. SPHD-001T-P0.5.

— SHP650 Series



Thermal Considerations (U Channel)

In order to ensure reliable operation in the end use application the recommended component temperatures listed should not be exceeded. Higher temperatures up to the maximum stated can be used but product lifetime may be reduced.

Component	Temperature Measurements (Ambient $\leq 50^{\circ}\text{C}$)	
	Recommended Temperature $^{\circ}\text{C}$	Max. Temperature $^{\circ}\text{C}$
T1 Coil	70 $^{\circ}\text{C}$	105 $^{\circ}\text{C}$
L1, LF1, LF2 Coil	90 $^{\circ}\text{C}$	120 $^{\circ}\text{C}$
EC1	70 $^{\circ}\text{C}$	105 $^{\circ}\text{C}$
EC8	100 $^{\circ}\text{C}$	120 $^{\circ}\text{C}$

Specification subject to change without notice