

65W CONVECTION COOLED

AC-DC POWER SUPPLIES

The AKM65 series of desktop adaptors comply with medical, home-healthcare and IT approvals along with the latest energy efficiency level VI standards with high active mode efficiency and extremely low no load power consumption. Available with a standard jack plug connector these adaptors suit a wide variety of cost sensitive industrial and medical applications while maintaining industry leading performance.



Features

- IP22 ingress protection
- IEC/EN60601-1-11 for home healthcare applications
- Energy efficiency level VI & EU2019/1782
- Medical (2 x MOPP) and ITE approvals
- Class I & class II versions
- Input voltage range 80 to 264VAC
- Output voltages from 12V to 48V
- 0°C to +60°C operating temperature
- 3 years warranty

Applications



Healthcare



Industrial Electronics



Medical Diagnostic



Technology

Dimensions

4.92" x 2.45" x 1.34" (125.0 x 62.3 x 34.0mm)

Models & Ratings

Model Number ⁽³⁾⁽⁴⁾	Output Power	Output Voltage	Output Current	Total Regulation ⁽¹⁾	Efficiency ⁽²⁾
AKM65US12	65W	12.0V	5.42A	5%	90.1%
AKM65US15		15.0V	4.30A	5%	90.9%
AKM65US18		18.0V	3.60A	5%	90.7%
AKM65US24		24.0V	2.70A	5%	90.5%
AKM65US48		48.0V	1.35A	5%	89.6%

Notes:

1. Total regulation includes initial set accuracy, line and load regulation.
2. Typical average value measured at 25%, 50%, 75% and 100% at 230VAC.
3. For white case version add suffix '-W' e.g. AKM65US12-W. MOQ applies, contact sales for details.
4. Model number shown in the table is for Class I version. For Class II version add suffix C2, e.g. AKM65US24C2.

Input

Characteristic	Minimum	Typical	Maximum	Units	Notes & Conditions
Input Voltage	80		264	VAC	
Input Frequency	47		63	Hz	
Input Current			2.0	A	90VAC
Inrush Current			100	A	230VAC, cold start at 25°C
No Load Input Power			150	mW	
Input Protection	Internal fuse in both line and neutral				

Output

Characteristic	Minimum	Typical	Maximum	Units	Notes & Conditions
Output Voltage	12		48	V	See Models and Ratings table
Minimum Load	0			A	No minimum load required
Start Up Delay			4	s	
Start Up Rise Time		30	55	ms	
Hold Up Time	10			ms	Full load and 100VAC
Total Regulation			5	%	See Models and Ratings table
Transient Response			4	% deviation	Recovery within <1% within 500µs for a 60% step load change at 0.15A/µs
Ripple and Noise			200	mV pk-pk	Measured with 20MHz bandwidth and 10µF electrolytic in parallel with 0.1µF ceramic capacitor
Overload Protection	130		160	%	
Short Circuit Protection	Continuous, trip and restart (hiccup mode) with auto recovery				
Temperature Coefficient			0.05	%/°C	

General

Characteristic	Minimum	Typical	Maximum	Units	Notes & Conditions
Efficiency		89		%	Typical average of efficiencies measured at 25%, 50%, 75% and 100% load and 115VAC input
Energy Efficiency					Level VI
Isolation: Input to Output	4000			VAC	Input to output, 2 x MOPP
Input to Ground	1500				Class I version only
Output to Ground					Negative output is connected to ground at class I version.
Leakage Current			100	µA	264VAC, 60Hz
Switching Frequency	24		70	kHz	Variable
Mean Time Between Failure	250			khrs	MIL-HDBK-217F at 25°C GB
Weight		0.75 (340)		lb (g)	

Environmental

Characteristic	Minimum	Typical	Maximum	Units	Notes & Conditions
Operating Temperature	0		+60	°C	Derate from 100% load at 40°C to 50% load at 60°C
Storage Temperature	-20		+70	°C	
Cooling	Natural convection				
Operating Humidity	5		90	%	RH, non-condensing
Operating Altitude			5000	m	
Shock	1m drop onto concrete on each of 6 axes, non operating				
Vibration	2g, 0.3 decades/min, 15 mins for each of 3 axes				

EMC: Emissions

Phenomenon	Standard	Test Level	Notes & Conditions
Conducted	EN55032	Level B	
Radiated	EN55032	Level B	
Voltage Flicker	EN61000-3-3		

EMC: Immunity

Phenomenon	Standard	Test Level	Criteria	Notes & Conditions
Medical Device EMC	IEC60601-1-2	Ed.4.0 : 2014	as below	
Low Voltage PSU EMC	EN61204-3	High severity level	as below	
ESD Immunity	EN61000-4-2	±8kV contact, ±15kV air	A	
Radiated Immunity	EN61000-4-3	10V/m	A	
EFT/Burst	EN61000-4-4	Level 3	A	
Surge	EN61000-4-5	Installation Class 3	A	
Conducted Immunity	EN61000-4-6	6V	A	
Magnetic Fields	EN61000-4-8	30A/m	A	
Dips and Interruptions	EN61000-4-11	Dip: 100% 10ms	A	
		Dip: 70% 500ms	B	
		Int: 100% 5000ms	B	
	EN60601-1-2	Dip: 30% 25 AC cycles	A	At 8 angles
		Int: 100% 0.5 AC cycle	A	
		Int: 100% 1 AC cycle	B	
		Int.: >95% 5000ms	B	

Safety Approvals

Certification	Safety Standard	Notes & Conditions
UL	UL 62368-1 & CAN/CSA C22.2 No. 62368-1-14	Information Technology
	ANSI/AAMI ES 60601-1	Medical, 2 x MOPP
EN	EN62368-1	Information Technology
	EN60601-1 (Class I & II versions), EN60601-1-11 (Class II version)	Medical, 2 x MOPP
CB	IEC60950-1:2005 Ed 2 / IEC62368-1	Information Technology
	IEC60601-1 (Class I & II versions), IEC60601-1-11 (Class II version)	Medical, 2 x MOPP
CCC	China Compulsory Certification, GB4943, GB17625.1, GB4943.1, GB/T9254	Information Technology
CSA	CSA C22.2 No. 60601	Medical, 2 x MOPP
AU/NZ	AU/NZ 60950.1	Information Technology
CE	Meets all applicable directives	
UKCA	Meets all applicable legislation	

Mechanical Details

AKM65USXX

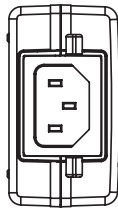

Class I inlet
IEC320-C14

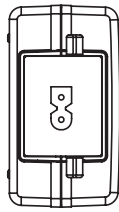

Class II inlet
polarised IEC320-C8

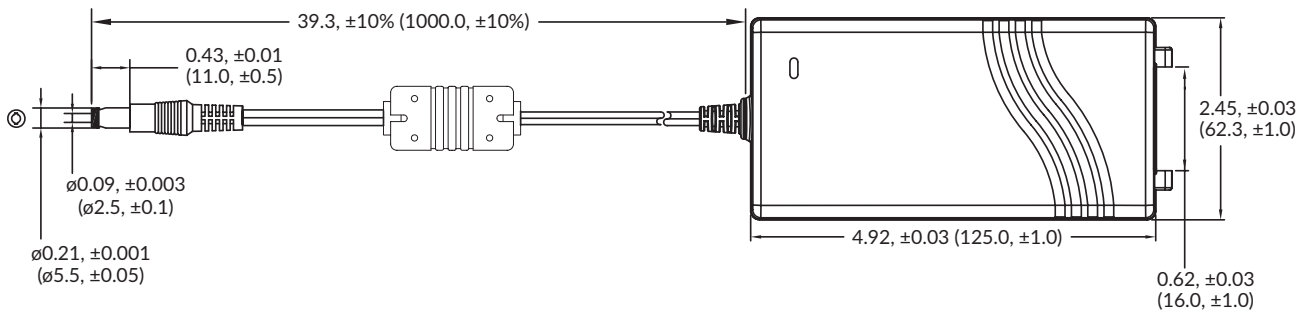
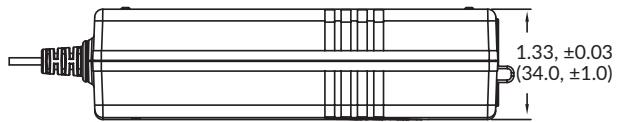
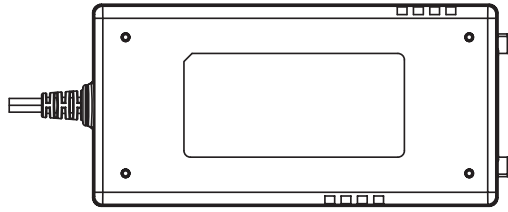

AKM65USXX with Optional AC Cable Restraint

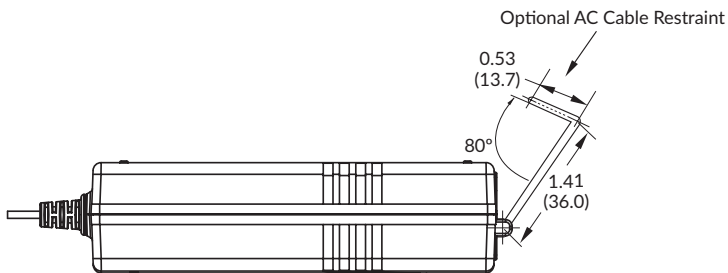
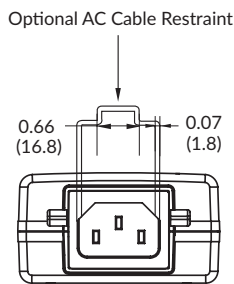

Notes:

- For optional AC cable restraint, order additional part AFM45-60 AC Clip.
- For correct restraint, AC mains lead must be Interpower Corporation, part number 70006020300. AC cable restraint is not suitable for use on Class II version.
- Output plug: $\phi 5.5 \times \phi 2.5 \times 11.0$ mm, centre positive.
- The standard IEC320-C7 cable fits the polarised IEC320-C8 (C8P) connector.

Specifications subject to change without notice.