

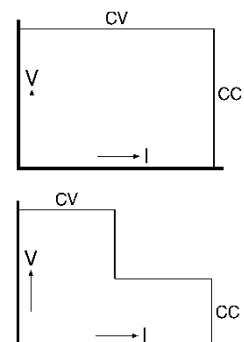

SM800 - Series 800W DC POWER SUPPLIES

Models	Voltage range	Current range
SM 7.5-80	0 - 7.5 V	0 - 80 A
SM 18-50	0 - 18 V	0 - 50 A
SM 70-AR-24	0 - 35 V	0 - 24 A
Autoranging output	0 - 70 V	0 - 12 A
SM 400-AR-4	0 - 200 V	0 - 4 A
Autoranging output	0 - 400 V	0 - 2 A



Features

- Designed for long life at full power
- Excellent dynamic response to load changes
- Protected against all overload and short circuit conditions
- EMC surpasses CE requirements: low emission & high immunity
- Low audible noise: temperature controlled fans
- Available options: analog & digital Interfaces, High Speed Programming, Digital Encoders, Sequencer, Power Sink etc.

Functionalities

- Master/Slave parallel and series operation with voltage and current sharing
- Stacking is allowed, space between units is not required
- High power system configuration from multiple units
- 19" rack mounting or laboratory use (feet included)
- Remote sensing
- Interlock

	SM 7.5-80	SM 18-50	SM 70-AR-24	SM 400-AR-4
DC Power terminals				
voltage	0 - 7.5 V	0 - 18 V	0 - 70 V	0 - 400 V
current	0 - 80 A	0 - 50 A	0 - 24 A	0 - 4 A
AUTORANGING (2 ranges)	no	no	yes	yes
Max. output current / voltages	/	/	24 A / 0-35 V 12 A / 35-70 V	4 A / 0-200 V 2 A / 200-400 V
AC Input				
single phase, 48 - 62 Hz	90-265 V	90-265 V	90-265 V	90-265 V
rated voltage range	100-240 V	100-240 V	100-240 V	100-240 V
rated frequency	50 / 60 Hz	50 / 60 Hz	50 / 60 Hz	50 / 60 Hz
rated current	max 10A	max 10A	max 10A	max 10A
Power Derating vs input:		$V_o = 16V$ $V_o = 18V$		
90 V : $P_{out\ max}$ (W), I_{in} (A)	580, 8.5	725, 10 670, 9.2	740, 10	750, 10
100 V: $P_{out\ max}$ (W), I_{in} (A)	600, 7.6	800, 9.9 730, 8.9	830, 10	800, 9.5
110 V: $P_{out\ max}$ (W), I_{in} (A)	600, 6.9	800, 8.8 770, 8.4	840, 9	800, 8.5
230 V: $P_{out\ max}$ (W), I_{in} (A)	600, 3.2	800, 4.1 900, 4.5	840, 4.2	800, 4
power factor, 100%, 50% load	0.99, 0.96	0.99, 0.98	0.99, 0.98	0.99, 0.98
internal fuses	12.5 AT	12.5 AT	12.5 AT	12.5 AT
standby input power ($V_o=I_o=0$)	14 W	14 W	14 W	14 W
standby input power ($V_o=V_{max}$)	18 W	18 W	20 W	26 W
Efficiency			35 V / 70 V	200 V / 400 V
230 V AC, 1 ph input, full load	82 %	87 %	89 %	89 %
115 V AC, 1 ph input, full load	80 %	83 %	85 %	86 %
Regulation				
Load 0 - 100% CV	0.2 mV	0.5 mV	2 mV	10 mV
Line 120 - 265 V AC CV (measured on sense block)	0.2 mV	0.2 mV	0.5 mV	2 mV
Load 0 - 100% CC	4 mA	3 mA	1.5 mA	0.5 mA
Line 120 - 265 V AC CC (internal voltage sense)	1 mA	1 mA	1 mA	0.2 mA
Ripple + noise				
rms (BW=300 kHz) CV	2.5 mV	2 mV	3 mV	15 mV
p-p (BW=20 MHz) CV	10 mV	8 mV	15 mV	80 mV
rms (BW=300 kHz) CC	25 mA	5 mA	3 / 1 mA	0.8 / 0.5 mA
p-p (BW=20 MHz) CC CC-ripple at full load	120 mA	25 mA	15 / 5 mA	3 / 1.5 mA
Front panel connection	Not available	Option 257	Option 258	Option 259
Load Regulation:				
Load 0 - 100% CV	-	15 mV	40 mV	15 mV
Ripple + noise				
rms (BW=300 kHz) CV	-	3 mV	4 mV	18 mV
p-p (BW=20 MHz) CV	-	18 mV	20 mV	150 mV
Temp. coeff., per °C¹			35.10 ⁻⁶ 60.10 ⁻⁶	
Stability¹ after 1 hr warm-up during 8 hrs CV CC			6.10 ⁻⁵ 9.10 ⁻⁵	
$t_{amb} = 25 \pm 1\ ^\circ C$, $V_{in} = 230\ VAC$			(internal voltage sensing for CC-stab.)	

Analog Programming	CV	CC
Programming inputs		
accuracy	0 - 5 V $\pm 0.2\%$	0 - 5 V $\pm 0.5\%$
offset	- 0.1 ... +1.3 mV (on 5V)	0 ... +2.2 mV (on 5V)
temp. coeff. offset	10 $\mu V / ^\circ C$	50 $\mu V / ^\circ C$
input impedance	> 1 MOhm	> 1 MOhm
Monitoring outputs		
accuracy	0 - 5 V $\pm 0.2\%$	0 - 5 V $\pm 0.2\%$
offset	- 1 ... 0 mV (on 5V)	- 1.1 ... 0 mV (on 5V)
temp. coeff. offset	3 $\mu V / ^\circ C$	60 $\mu V / ^\circ C$
input impedance	2 Ohm / max. 4mA	2 Ohm / max. 4mA
ISO AMP Programming (optional)	Isolated analog programming, range 0 - 5 V / 200 kOhm or 0 - 10 V / 400 kOhm. See datasheet ISO AMP on www.DeltaPowerSupplies.com for accuracy, offset etc.	
Reference voltage on prog. connector	V_{ref} TC	5.114 ± 15 mV ($R_o = 2$ Ohm, max. 4 mA) 20 ppm
+12 V output on prog. Connector	V_o I_{max} R_o	12 V ± 0.2 V 0.2 A 3 Ohm

Notes: 1. Measured at full load. 2. See "Safety instructions".

Status Outputs	CC - status LIM - status OT - status PSOL - status ACF - status DCF - status	CC - operation CV or CC limit Over Temperature Power Sink Overload AC - Fail DC - Fail ¹⁾	5 V = logic 1 (Ro = 500 Ohm) 5 V = logic 1 (Ro = 500 Ohm) 5 V = logic 1 (Ro = 500 Ohm) 5 V = logic 1 (Ro = 500 Ohm) 5 V = logic 1 (Ro = 500 Ohm) 5 V = logic 1 (Ro = 500 Ohm)
Relay Outputs	ACF DCF	AC - Fail DC - Fail ¹⁾	both NO and NC contact both NO and NC contact ¹⁾ output ± 5% beyond set point
Remote shutdown	with + 5 V, 1 mA or relay contact		
Interlock	contact at rear panel, see photo of rear panel on page 1-6		
Indicators (front panel)	AC-Fail, DC-Fail, Over Temperature, Power Sink Overload, Remote-ShutDown, Remote-CV, Remote-CC, Output On, CV-limit, CC-limit, CV- and CC- mode		
Controls (front panel)	Mains on/off, CV-and CC-potmeter, CV- and CC-limit-potmeter, Display-Settings button, Display-Limits button, Remote/Local, Output On/Off, Front panel Lock		

Programming speed <i>Standard Version</i> (resistive load)	SM 7.5-80	SM 18-50	SM 70-AR-24	SM 400-AR-4
Rise time (10 - 90%)				
output voltage step	0 → 7.5 V	0 → 16 V	0 → 35 V	0 → 200 V
time, (100 % load)	6.5 ms	12 ms	6 ms	4 ms
time, (10 % load)	2.5 ms	5 ms	2.5 ms	2 ms
output voltage step	-	-	0 → 70 V	0 → 400 V
time, (100 % load)	-	-	10 ms	8 ms
time, (10 % load)	-	-	7 ms	5 ms
Fall time (90 - 10%)				
output voltage step	7.5 → 0 V	16 → 0 V	35 → 0 V	200 → 0 V
time, (100 % load)	6.5 ms	12 ms	6 ms	4 ms
time, (10 % load)	62 ms	120 ms	60 ms	42 ms
output voltage step	-	-	70 → 0 V	400 → 0 V
time, (100 % load)	-	-	25 ms	15 ms
time, (10 % load)	-	-	250 ms	155 ms
Programming speed <i>Optional High Speed</i> (resist. load)	SM 7.5-80 <i>Option P250</i>	SM 18-50 <i>Option P251</i>	SM 70-AR-24 <i>Option P252</i>	SM 400-AR-4 <i>Option P253</i>
Rise time (10 - 90%)				
output voltage step	0 → 7.5 V	0 → 16 V	0 → 35 V	0 → 200 V
time, (100 % load)	0.2 ms	0.22 ms	0.24 ms	0.4 ms
time, (10 % load)	0.2 ms	0.26 ms	0.24 ms	0.3 ms
output voltage step	-	-	0 → 70 V	0 → 400 V
time, (100 % load)	-	-	0.24 ms	0.82 ms
time, (10 % load)	-	-	0.24 ms	0.55 ms
Fall time (90 - 10%)				
output voltage step	7.5 → 0 V	16 → 0 V	35 → 0 V	200 → 0 V
time, (100 % load)	0.2 ms	0.24 ms	0.27 ms	0.42 ms
time, (10 % load)	1 ms	1.95 ms	3 ms	4.6 ms
output voltage step	-	-	70 → 0 V	400 → 0 V
time, (100 % load)	-	-	0.85 ms	1.7 ms
time, (10 % load)	-	-	9.5 ms	20 ms
Ripple @ full load				
typical (rms/pp)	20 / 80 mV	40 / 120 mV	35 V / 24 A 25 / 90 mV 70 V / 12 A	200V / 4 A 35 / 200 mV 400 V / 2 A
typical (rms/pp)			30 / 110mV	30 / 160 mV
Output Capacitance (typical)	310 µF	200 µF	80 µF	4 µF

	SM 7.5-80	SM 18-50	SM 70-AR-24	SM 400-AR-4
Recovery time				
recovery within	50 mV	60 mV	35 / 70 V 75 mV	200 / 400 V 1.0 / 0.5 V
di/dt of load step	1.25 A/µs	0.9 A/µs	0.4 / 0.2 A/µs	0.1 / 0.05 A/µs
output voltage	7 V	15 V	30 / 65 V	185 / 370 V
time, @ 50 - 100% load step	100 µs	100 µs	100 µs	100 µs
max. deviation	160 mV	150 mV	250 / 200 mV	2 / 1.5 V
Output impedance				
CV, 0-1 kHz	< 1 mΩ	< 2 mΩ	< 7 mΩ	< 0.18 Ω
CV, 1-100 kHz	< 30 mΩ	< 30 mΩ	< 35 mΩ	< 2 Ω
Pulsating load max. tolerable AC component of load current f > 1 kHz, f < 1 kHz	15 A _{rms} , 80 A _{peak}	15 A _{rms} , 50 A _{peak}	10 A _{rms} , 24 / 12 A _{peak}	0.4 A _{rms} , 4 / 2 A _{peak}

Notes: 1. Measured at full load. 2. See "Safety instructions".

Insulation AC mains / DC power terminals creepage / clearance AC mains / case DC power terminals / case	3750 V _{rms} (1min.) 8 mm 2500 V _{rms} 600 V DC ²
Safety	EN 60950 / EN 61010
EMC Emission Immunity	EN 61326-1 , class B equipment (for use in domestic establishments) EN 61326-1 , equipment for use in industrial and domestic establishments

Operating Temperature	- 20 to + 50 °C @ full load, derate output to 75% at 60 °C
Humidity	maximum 95% RH, non condensing, up to 40 °C maximum 75% RH, non condensing, up to 50 °C
Storage temperature	- 40 to + 70 °C
Thermal protection	output shuts down in case of insufficient cooling
MTBF	500 000 hrs

Hold-Up time (@ 230 VAC input) V _{out} = 100%, P _{out} ≤ 840 W V _{out} = 85%, I _{out} = 100% V _{out} = 100%, I _{out} = 50%	16 ms 20 ms 36 ms
Turn on delay after mains switch on	600 ms @ 230 VAC, 900 ms @ 115 VAC
Inrush current	22 A @ 230 VAC, 24 A @ 115VAC

	SM 7.5-80	SM 18-50	SM 70-AR-24	SM 400-AR-4
Series operation max. total voltage Master / Slave operation	600 V ² yes			
Parallel operation Normal Master / Slave operation	no limit maximum 4 units			
Remote sensing max. voltage drop per load lead	2 V			
Limits Voltage adjust range Current adjust range	0 - 102 % 0 - 102 %			
Front panel CV/CC-controls resolution knob operation screwdriver adjustment Lock function for CV/CC-settings Selectable Start-up at 0V / 0A or at last settings	analog potentiometers ³⁾ 10 turns (0.03%) standard optional (P001) no ³⁾ no ³⁾ ^{3) optional with digital encoders (P236).}			
Meters scale voltage scale current accuracy read output read limit setting (d = digit)	3.5 digit 0 - 7.50 V 0 - 80.0 A 0.5% + 2d 2% + 2d	3.5 digit 0 - 18.00 V 0 - 50.0A 0.5% + 2d 2% + 2d	3.5 digit 0 - 70.0V 0 - 24.0 A 0.5% + 2d 2% + 2d	3.5 digit 0 - 400 V 0 - 4.00 A 0.5% + 2d 2% + 2d

Mounting	stacking of units allowed, air flow is from rear to sides
AC Terminals	IEC320/C14, EN60320/C14
DC Terminals	M5 bolts
Programming connector	15 pole D-connector at rear panel (Female)
Interlock	contact at rear panel
Cooling audio noise level air flow	low noise blower, fan speed adapts to temperature of internal system ca. 45 dBA at full load, 25 °C ambient temperature, 1 m distance ca. 50 dBA at full load, 50 °C ambient temperature, 1 m distance From rear to sides
Enclosure degree of protection	IP20
Dimensions front panel: h x w behind front panel: h x w x d	88.1 x 222 mm (1/2 19", 2 U) 86 x 221 x 406 mm (feet removed)
Weight	5.4 kg

Notes: 1. Measured at full load. 2. See "Safety instructions".

Typical Applications

- Accurate current sources
- Automotive battery simulations
- Driving PWM-Controlled DC motors
- Electronic circuit design
- Controlled battery (dis)charging
- Medical research equipment
- Component device testing
- Lasers
- Aerospace and military equipment
- ATE in industrial production lines

Available Options



Increased Output Power

The conservatively rated unit allows to deliver extra output with the same reliability.

At some derating, either the maximum output voltage or the maximum output current can be increased by about 10%.

Order Code :

- P069



High Speed Programming

A 10 to 20 times higher programming speed (down to 0.2ms rise time at full load) and lower output capacitance¹⁾. Excellent for laser applications, test systems or as current source with low parallel capacitance as used in plasma chambers.

Order Codes :

- SM 7.5-80 P250
- SM 18-50 P251
- SM 70-AR-24 P252
- SM400-AR-4 P253



Two-Quadrant Output Power Sink

Two quadrant operation maintains the DC output voltage constant regardless the output power is positive or negative¹⁾. Ideal for PWM-speed controlled DC-Motors and ATE systems.

Order Codes :

- SM 7.5-80 P245
- SM 18-50 P246
- SM 70-AR-24 P247
- SM400-AR-4 P248



Sequencer

Arbitrary Waveform generator or standalone automation. The sequencer is integrated in the Ethernet controller.

Order Code :

- P256



Digital CV- and CC-Settings

Reliable, long-life digital encoders can be implemented at the front panel. Includes total front panel lock (also for CV- / CC-knobs) and a coarse or fine pitch adjustment depending on the turning speed.

Order Code :

- P236



Secured Voltage and Current Settings

For maximum security, the CV/CC settings can be adjusted with a screwdriver only and are protected with a plastic cap from accidental adjusting.

Order Code :

- P001



Software Control and Interfaces

Interfaces to be installed by factory ²⁾.

Order Codes:

- Ethernet controller (including sequencer) - P256
- ISO AMP Card - isolated analog - P249
- RS232 controller - P254



19" Rack Mounting adapter

The 19" mounting adapters make it possible to position one or two units side by side in a 19" rack.

Order Codes:

- RA19 - 1SM800 (for 1unit)
- RA19 - 2SM800 (for 2units)



Front Power Output

Bind posts at the front panel instead of at the rear panel.

Order Codes :

- SM 7.5-80 n.a.
- SM 18-50 P257
- SM 70-AR-24 P258
- SM400-AR-4 P259

Notes: 1. Download datasheets about High Speed Programming, Power Sink and Battery Charging from www.DeltaPowerSupplies.com.
2. There is only room for one of the interfaces in a unit.

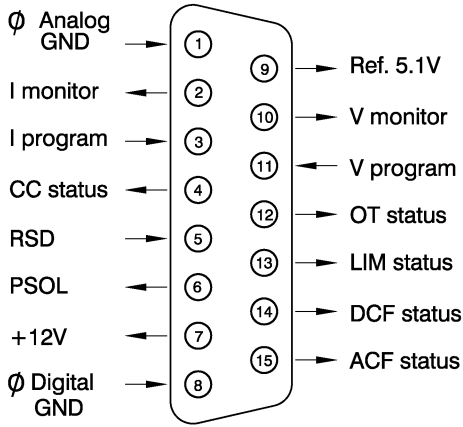

CV = Constant Voltage
 CC = Constant Current

Specifications measured at
 $t_{amb} = 25 \pm 5 \text{ }^\circ\text{C}$ and $V_{in} = 230 \text{ VAC}$,
 50 Hz unless otherwise noted.

The information in this document is
 subject to change without notice.

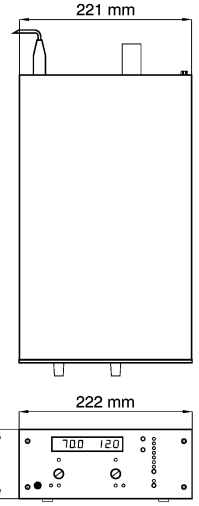

Connections analog programming connector

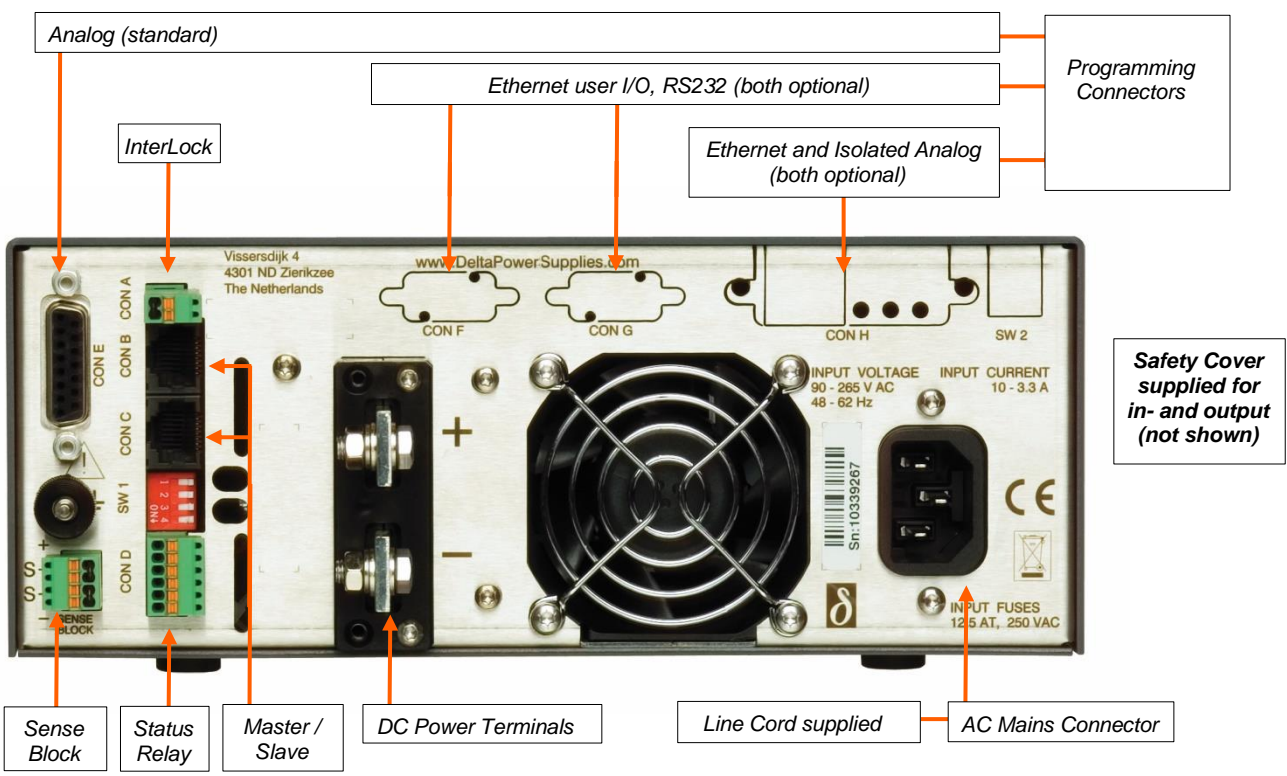

19" Rack Adapter RA19-2 SM800



Front panel connection:
 SM18-50 Option P257
 SM70-AR-24 Option P258
 SM400-AR-4 Option P259



19" Rack Adapter RA19-1 SM800