

GSP750 Series



750W **FAN COOLED** | 50W **CONVECTION COOLED**

AC-DC POWER SUPPLIES

The GSP750 has been designed to offer a full 750W of output power in a very small mechanical footprint, whilst still providing peak power to 900W, a 5V standby output with a 3A capability and an input standby power draw of <1W when the inhibit is activated.

Approved for both IT/industrial and medical applications the series has output versions from 12V to 48V. Cooling fans are intelligently controlled to reduce acoustic noise in the system and the GSP750 provides up to 50W without forced cooling, allowing the fans to be switched off, providing silent running during periods of lower system loading or system standby conditions.



Features

- Low profile, compact size
- Suitable for 1U applications
- 900W peak power rating for 100ms
- Universal 80-264VAC input (300VAC for 5s)
- IT/industrial and medical (2 x MOPP) safety approvals
- 5V/3A standby output
- 1.0W standby power
- Intelligent fan speed control
- -40°C to +70°C operation
- PowerFail, inhibit, remote sense and current share
- 3 year warranty

Applications



Healthcare



Industrial
Electronics



Instrumentation



Medical
Diagnostic



Technology

Dimensions

10.0 x 4.0 x 1.65" (254.0 x 101.6 x 41.9 mm)

Models & Ratings

Model Number	Output Voltage	Output Current V1	Standby Supply		Max Output Power	
			<50W Load (Fans Off)	<50W Load (Fans On)	Nom	Peak ⁽¹⁾
GSP750PS12-EF	12.0VDC	62.5A	5V/1A	5V/3A	750W	900W
GSP750PS24-EF	24.0VDC	31.3A	5V/1A	5V/3A	750W	900W
GSP750PS48-EF	48.0VDC	15.6A	5V/1A	5V/3A	750W	900W

Notes:

1. Peak power available for 100ms maximum with a 10% duty cycle. The average power in a period should be equal or less than the nominal power.

Summary

Characteristic	Minimum	Typical	Maximum	Units	Notes & Conditions
Input Voltage - Operating	80	115/230	264	VAC	Derate output power <90VAC. See fig 1
No Load Input Power			1	W	All models, when inhibit activated
Efficiency		90		%	230VAC Full load, see fig. 3-5
Operating Temperature	-40		+70	°C	
EMC	EN55011/32 Level B Conducted & Class A and B Radiated				
Safety Approvals	IEC60950-1, IEC62368-1, IEC60601-1 Including Risk Management, UL62368-1, CSA62368-1 via cUL, ANSI/AAMI ES60601-1 & CSA C22.2, No.60601-1, EN62368-1, EN60601-1, LVD & RoHS, Equipment Protection Class I				
Weight		2.97 (1.35)		lb (kg)	

Input

Characteristic	Minimum	Typical	Maximum	Units	Notes & Conditions
Input Voltage - Operating	80	115/230	264	VAC	Derate output power <90VAC. See fig 1
Input Voltage - Fault Condition			300	VAC	5 second max
Input Frequency	47	50/60	63	Hz	
Power Factor		>0.9			230VAC, 100% load
Input Current - Full Load		8.7/4.35		A	115/230VAC
Inrush Current		60		A	
Earth Leakage Current		80/220	250	µA	115/230VAC/50Hz Typ., 264VAC/60Hz Max
No Load Input Power			1	W	All models, when inhibit activated
Input Protection	F16A/250V internal fuse in both lines				

Input Voltage Derating Curve

Figure 1

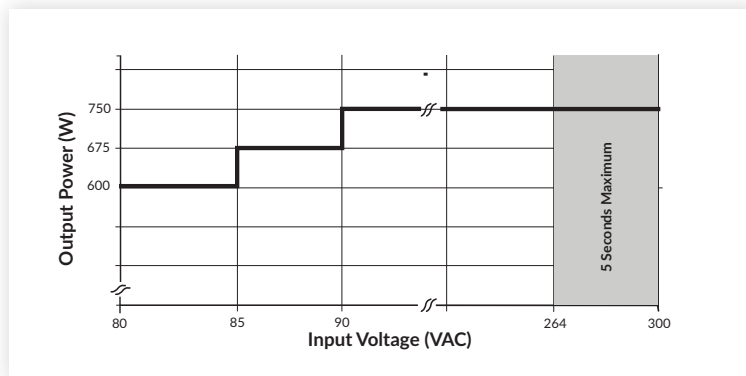

Output

Characteristic	Minimum	Typical	Maximum	Units	Notes & Conditions
Output Voltage - V1	12		48	VDC	See Models & Ratings table
Initial Set Accuracy			±1	%	50% load, 115/230VAC
Output Voltage Adjustment - V1			+1,-3	%	
Minimum Load	0			A	
Start Up Delay		1.0	2.0	s	115/230VAC, full load from input AC turn on
Hold Up Time	10			ms	100% load
Drift			±0.5	%	After 20 min warm up
Line Regulation			±0.5	%	90-264VAC
Load Regulation		0.2	1.0	%	0-100% load
Transient Response			4	%	Recovery within 1% in less than 500µs for a 50-75% and 75-50% load step
Over/Undershoot			5	%	
Ripple & Noise		0.5	1.5	% pk-pk	20MHz bandwidth
Oversvoltage Protection	115		140	%	Vnom DC. Output 1, recycle input to reset
Overload Protection	110		150	% I nom	See fig. 2. Trip and Restart
Short Circuit Protection	Shutdown and autorecovery				
Temperature Coefficient			0.05	%/°C	
Overtemperature Protection	Shutdown and autorecovery				

Output Overload Characteristic

Figure 2
GSP750PS12 example (others similar)

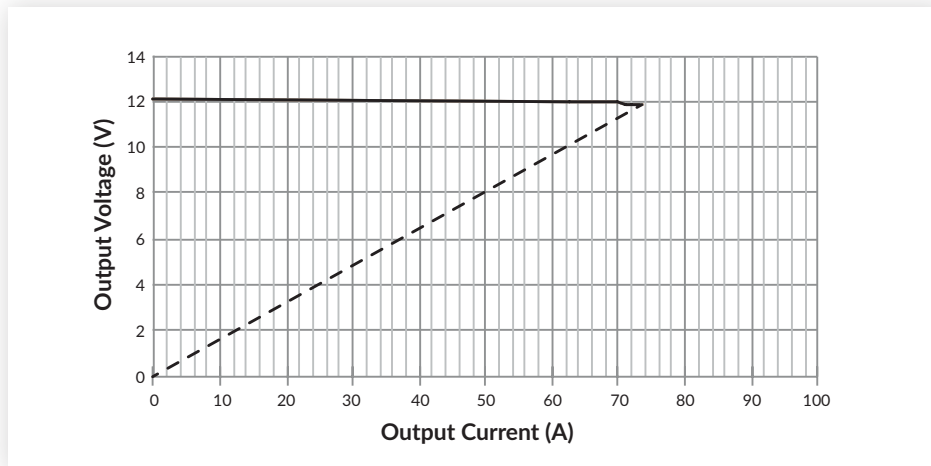

General

Characteristic	Minimum	Typical	Maximum	Units	Notes & Conditions
Efficiency		90		%	230VAC Full load (see fig. 3-5)
Isolation: Input to Output	4000			VAC	2 x MOPP
	Input to Ground	1500		VAC	1 x MOPP
	Output to Ground	500		VDC	1 x MOPP at 48VDC
Switching Frequency		65		kHz	PFC converter
	50	90	200		Main converter
		100			Standby converter
Power Density			11.7	W/in ³	
Mean Time Between Failure		186		khrs	MIL-HDBK-217F, Notice 2 +25°C GB
Weight		2.97 (1.35)		lb (kg)	

Efficiency Graphs

Efficiency vs Load

Figure 3
GSP750PS12

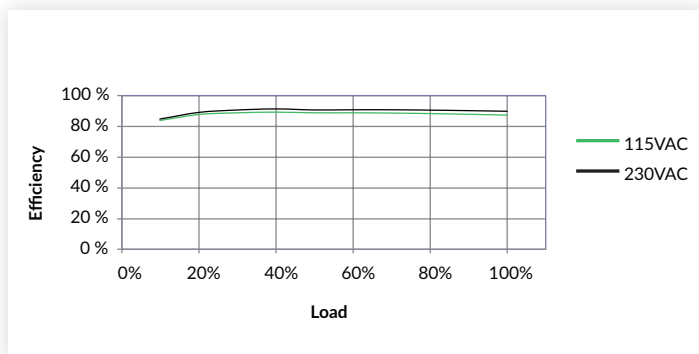

Figure 4
GSP750PS24

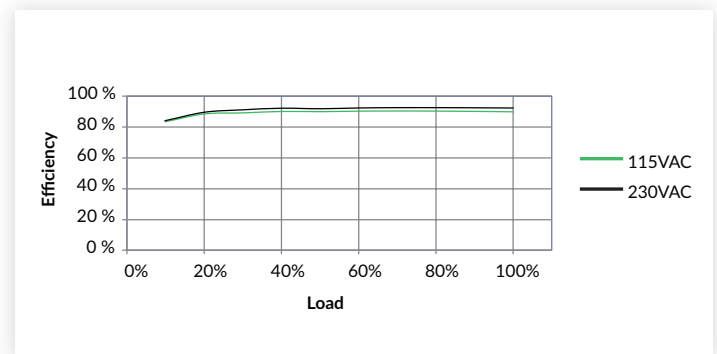
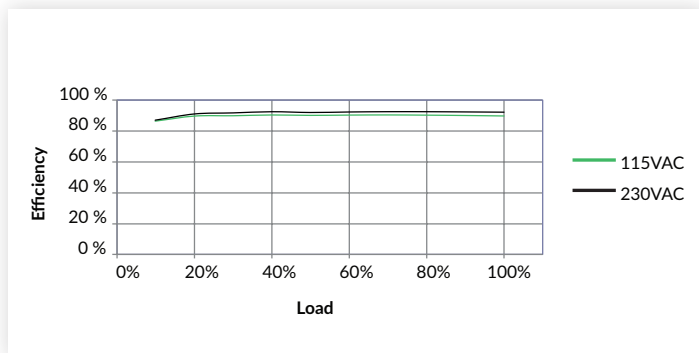

Figure 5
GSP750PS48



Signals & Controls

Characteristic	Notes & Conditions
Power Fail (PF)	Open collector referenced to negative sense, transistor normally on when power is good (see fig. 6); power is considered good when AC input voltage is normal. PF: Provides ≥ 5 ms warning of loss of output from power failure/loss of AC input voltage.
Inhibit	Uncommitted isolated optocoupler diode, powered diode inhibits both V1 and fan supply (see fig. 7). During inhibit the standby supply and current should be limited to 1A for thermal reasons.
Output Good	LED Indicator
Fan Speed Control	The fan speed is set to one of 4 states (high, mid, low or off) dependant on the internal power supply ambient temperature, input voltage and output load at any given time
Standby Supply	5V/3A isolated supply present when AC applied.
Remote Sense	Compensates for 0.5V total voltage drop.
Current Share	Connecting pins 5 or 6 on one unit to pins 5 or 6 on another like voltage unit will force the current to be shared within 10% between the two outputs. Up to three units can share current. (see fig. 8)

Power Fail (PF)

Figure 6

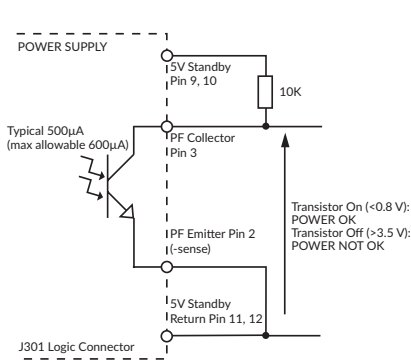

Remote On/Off (Inhibit)

Figure 7

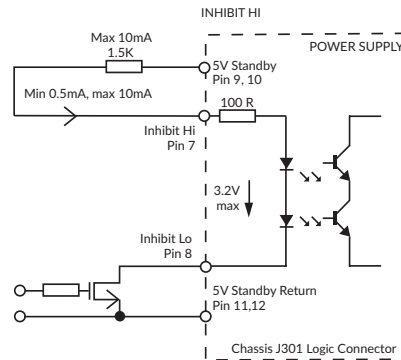

Signal High: Power Supply OFF
 Low or Floating: Power Supply ON

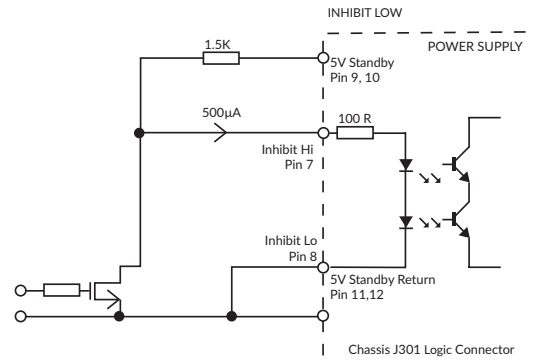

Signal High: Power Supply ON
 Low or Floating: Power Supply OFF

Current Share

Figure 8

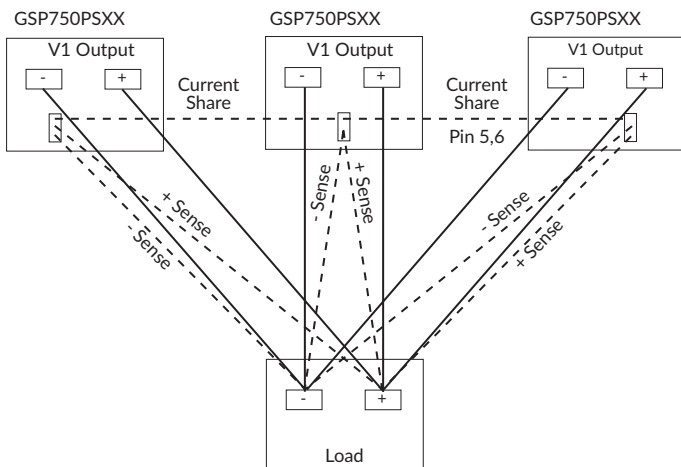

Environmental

Characteristic	Minimum	Typical	Maximum	Units	Notes & Conditions
Operating Temperature	-40		+70	°C	Start up at -40°C. See derating curve, fig. 9
Storage Temperature	-40		+85	°C	
Humidity	5		95	%RH	Non-condensing
Operating Altitude			5000	m	
Acoustic Fan Noise		65.0		Lw dB (A)	Full speed
		56.0			Mid speed
		42.0			Low speed
Shock	3 x 30g shocks in each plane, total 18 shocks. 30g = 11ms (±0.5msec), half sine. Conforms to EN60068-2-27 & EN60068-2-47				
Vibration	Single axis 10-500 Hz at 2g sweep and endurance at resonance in all 3 planes. Conforms to EN60068-2-6				

Temperature Derating Curve

Figure 9

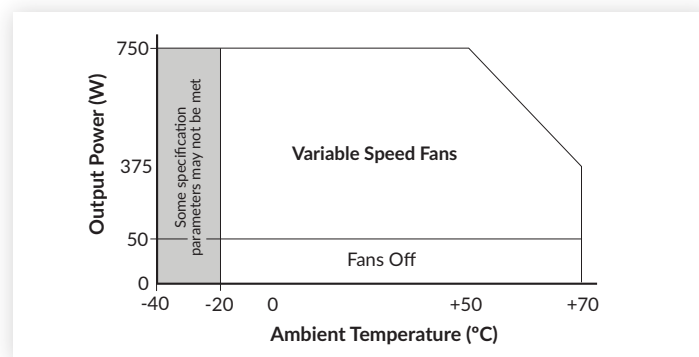

EMC: Emissions

Phenomenon	Standard	Test Level	Notes & Conditions
Conducted	EN55011/32	Class B	
		Class A	
Radiated	EN55011/32	Class B	With Wurth 742 712 22(S) on input cable and Wurth 742 715 4(S) on output cable
Harmonic Fluctuations	EN61000-3-3		

EMC: Immunity

Phenomenon	Standard	Test Level	Criteria	Notes & Conditions
Low Voltage PSU EMC	EN61204-3	High severity level	as below	
Harmonic Current	EN61000-3-2	Class A		All models
		Class C		>50W
Radiated	EN61000-4-3	3	A	
EFT	EN61000-4-4	3	A	
Surges	EN61000-4-5	Installation class 3	A	
Conducted	EN61000-4-6	3	A	
Dips and Interruptions	EN55035 (100VAC)	Dip >95% (0VAC), 8.3ms	A	
		Dip 30% (70VAC), 416ms	A	
		Dip >95% (0VAC), 4160ms	B	
	EN55035 (240VAC)	Dip >95% (0VAC), 10ms	A	
		Dip 30% (168VAC), 500ms	A	
		Dip >95% (96VAC), 5000ms	B	
	EN60601-1-2 (100VAC)	Dip >95% (0VAC), 10ms	A	
		Dip >95% (0VAC), 20ms	B	Derate Output Power to 70% for criteria A
		Dip 60% (40VAC), 100ms	A	Derate Output Power to 50%
		Dip 30% (70VAC), 500ms	A	
		Dip >95% (0VAC), 5000ms	B	
	EN60601-1-2 (240VAC)	Dip >95% (0VAC), 10ms	A	
		Dip >95% (0VAC), 20ms	B	Derate Output Power to 70% for criteria A
		Dip 60% (96VAC), 100ms	A	
Dip 30% (168VAC), 500ms		A		
Dip >95% (0VAC), 5000ms		B		

Safety Approvals

Certification	Standard	Notes & Conditions
CB	IEC60950-1 & IEC62368-1	Information Technology
	IEC60601-1 Including Risk Management	Medical
UL	UL62368-1, CSA62368-1 via cUL	Information Technology
	ANSI/AAMI ES60601-1 & CSA C22.2, No.60601-1	Medical
TUV	EN62368-1	Information Technology
	EN60601-1	Medical
Equipment Protection Class	Class I	See safety agency conditions of acceptability for details
CE	Meets all applicable directives	
UKCA	Meets all applicable legislation	
Isolation	Means of Protection	Category
Primary to Secondary	2 x MOPP (Means of Patient Protection)	IEC60601-1
Primary to Earth	1 x MOPP (Means of Patient Protection)	
Secondary to Earth	1 x MOPP at 48VDC	

GSP750 Series

Mechanical Details

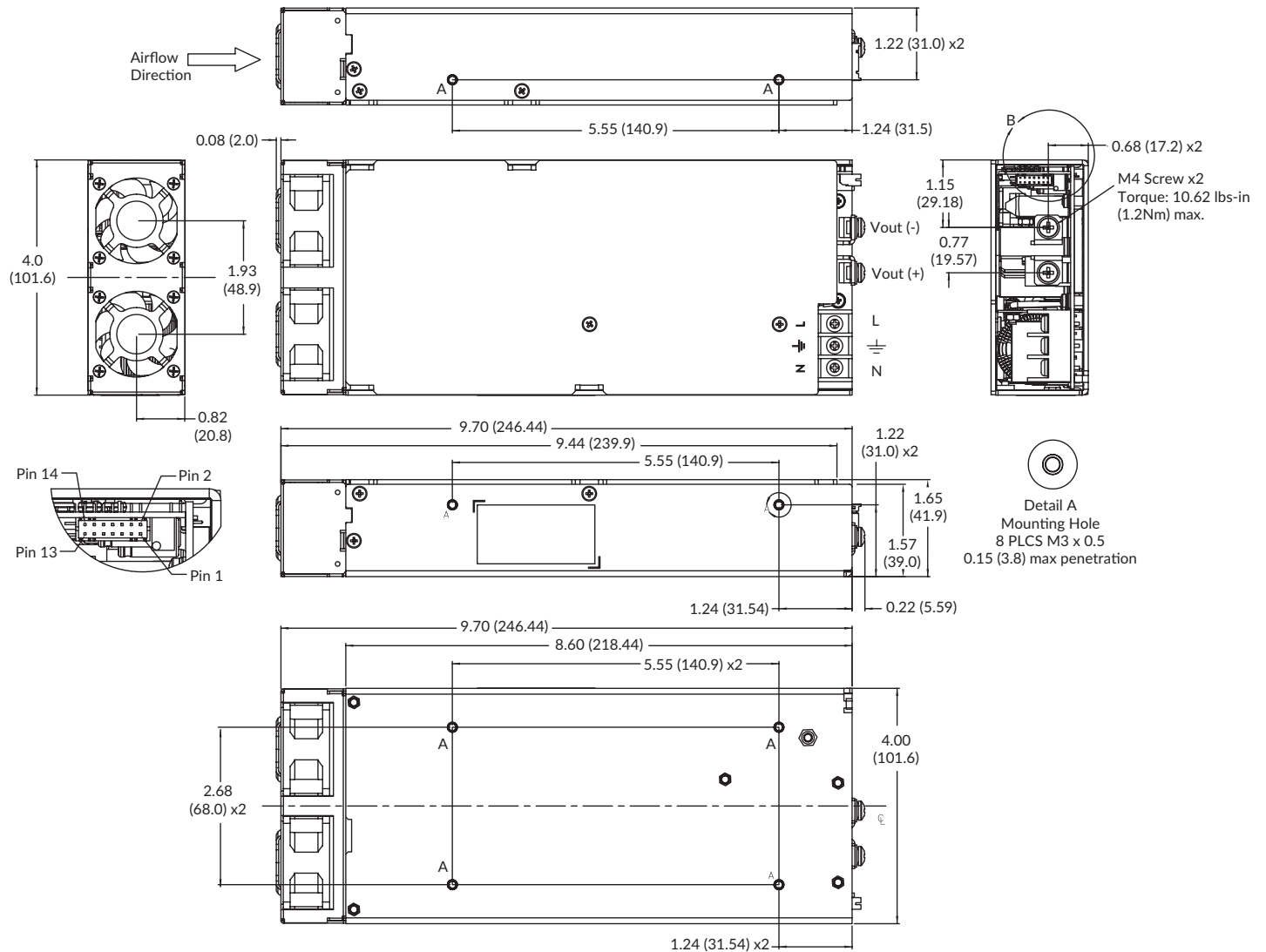

Logic Connector ⁽³⁾ JST B14B-PHDSS			
Pin	Single	Pin	Single
1	+Sense	8	-Inhibit
2	-Sense	9	+5V Standby
3	Power Fail	10	+5V Standby
4	No Connection	11	5V Standby Return
5	Current Share	12	5V Standby Return
6	Current Share	13	No Connection
7	+Inhibit	14	No Connection

- Notes:**
- All dimensions in inches (mm)
 - Tolerance .xx = ±0.02 (0.50); .xxx = ±0.01 (0.25)
 - Logic connector J301 mates with JST housing PHDR-14VS and SPHD-001T-P0.5 crimp terminals.

Specifications subject to change without notice.