

ESB00351 DIN Rail

Inrush Current Limiter, Inrush Current Protection

For half inductive & capacitive loads, 230Vac 35A_{peak}/24,8A_{eff} -20°C...+70°C

Short Specification:

- Input 230Vac, 30A cont. current
- Load capacity 10.000uF
- DIN Rail TS35mm
- Screw terminals 0,5...16mm²/AWG22-6
- Integrated power supply
- Integrated bypass-relay
- Low voltage detection
- Maintenance free
- IP20 metal housing
- Power LED

The ESB00351-series has been engineered as totally professional inrush limiter. An ESB00351 provides high recommended and trouble free operation with capacitive and half inductive loads. The ESB00351 is optimized for LED-application, complex machine building and for the automation. As the ESB00351 features a built in power supply, existing equipment can be upgraded very simple.

No simple NTC design! An ESB00351 allows the effective reduction of the wire cross section. It is recommended for the usage of quicker and smaller circuit breakers.



In accordance with IEC60950-1

Input Voltage Range	184...265Vac oder 85...132Vac , 47...63Hz
Nominal Input Voltage	230Vac
Nominal Current	30A continuous
Order Code	230Vac ESB00351.T (example for customized Ton/Toff = ESB00351.T.300/120 e.g.300/120ms)

Interval per Minute Ambient	3 Zyklen +60°C /5 Zyklen + 40°C
Current Limiting Peak	35A peak ± 6%
Current Limiting RMS	24,8A rms ± 6%
Temperature-drift	Within ± 6% tolerance
Capacitive Load	10.000uF max.
Recommended Circuit Breaker	≥13A characteristic (A)
Inrush Limiting Time	Ton = 150ms (standard setting)
Low Voltage Detection	Tout = 100ms (standard setting)
Cooling	Natural convection
Ambient Temperature	-20°C...+70°C (+60°C derating)
Storage Temperature	-40°C...+85°C for 3 years
Humidity Operation	95% (+25°C) not condensing
Pollution Degree	2 (IEC/EN50178)
Maximum Altitude Operation	3000m (9842 ft.) over sea level
Environmental Conditions	Climatic class 3K3, mech.3M4 (EN60721)
EMS	EN61000-6-2,3
EMI	EN55022 class B / EN61000-3-2
Safety	cUL60950, EN60950-1, EN60204
Safety Class SELV 1(A)	VDE0805, VDE0100
Creepage distance	> 4mm
MTBF (IEC61709)	622.732h +40°C
MTTF (IEC60050)	148.512h +40°C
Dimensions (HxBxT)	124x65x99.5mm
DIN Rail EN60715	TS35/15 TS35/7.5
Weight (netto)	810g
Connections EN60664-1/61984	Screw terminals 0,5...16mm ² AWG22-6

Custom Inrush Limiting Time & Low Voltage Detection :

Name desired values. Blank values mean standard settings (p.3). The custom settings can only be adjusted from the factory.

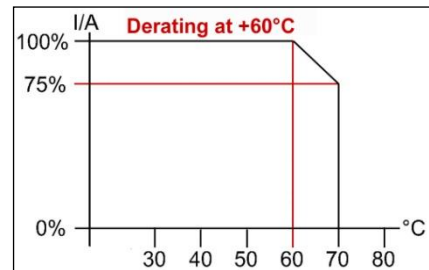

Connections:

Input	PE = GND L N
Output	PE = GND L N

General Description:

The ESB00351 is no simple NTC design. As a pure peak inrush protection the it limits the current at the switch on moment of the connected load. The ESB00351 operates with a tolerance of ±6%, independent from the ambient temperature. The ESB00351 has been designed for high recommended and trouble free operation in professional LED-applications, plant engineering and for traffic control systems.

Plant Engineering:

Undesired voltage drops from unstable AC-networks may cause undefined high inrush when the connected loads restart all at once. The pre installed circuit breakers can be tripped. The ESB00351 protects from tripping the CB. Contactors will be protected from burned or welded contacts.

UPS & Online-Converter:

After a system down the connected loads start force the online converters into the internal current limiting mode. In fact most converters answer with a shutdown or hiccup operation. The ESB protects the converters from over current mode.

Traffic control systems & LED displays:

ESB00351 are specially designed for capacitive loads. A high number of switch mode power supplies cause inrush exceeding >1000A. The ESB limits the inrush reliable and reproducible with a tolerance of ±6%. An ESB00351 allows reducing the wire cross section and the usage of smaller and quicker circuit breakers. **LED-Lighting**, mostly recommend to install a huge number of AC/DC supplies into the AC network. Most convenience LED-switchers provide an unprecise NTC inrush limiting. Heat additionally reduces the ohmic resistance of the NTC and causes the inrush to expand. An inrush of 40A plus is not seldom in a simple 45W LED supply. This fact limits the quantity of LED power supplies being connected to a single circuit breaker. Using the ESB00351 mostly saves a big number of circuit breakers. In some installations the amount of wiring work can be reduced down to 25% of the former cost.

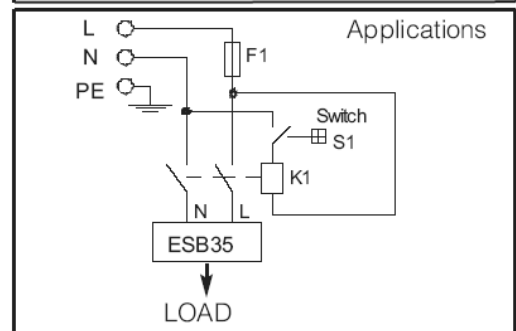
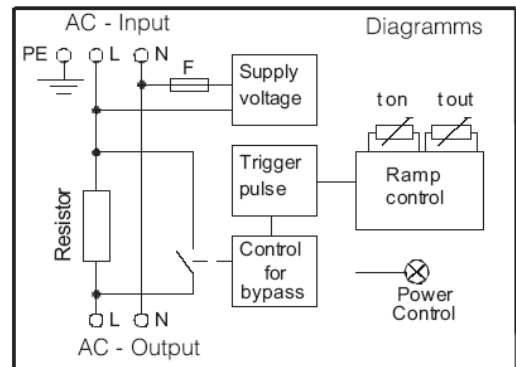

Practical Operation:

The ESB limiter allows connecting much more loads (e.g. LED-power supply / LED-drivers) to a pre-installed circuit breaker CB (Fig.2). The ESB definitely avoids that the CB will be tripped. This fact occur independent from the objective initial current. The result is that the number of A.C. branch lines and the pre-installed CB can be reduced dramatically. Installation cost exhibit a sustained decline.

Additionally the cross section of the branch lines can be reduced when using smaller and faster responding circuit breakers. The cost saving from copper is essential. Sensitive AC networks can be fused safer (e.g. Traffic Control Systems, Street-Lighting, Parking Lots and Tunnels)

When the ESB00351 is installed correctly, the neutral wire (N) is looped trough (Fig.1). The inrush protection circuit always acts to the line conductor. The load is connected with the AC in such a way that a circuit breaker or an earth-leakage-trip works within the limits of the legal rules. This fact is also applied while the limiting circuit acts.



Abb.1



Inrush without ESB00351

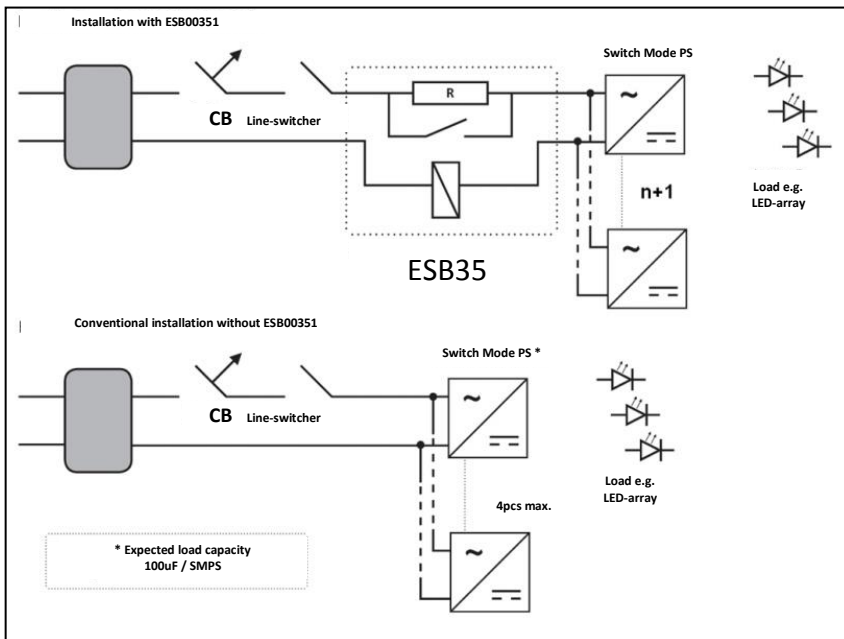
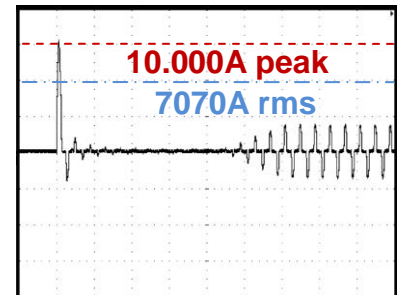
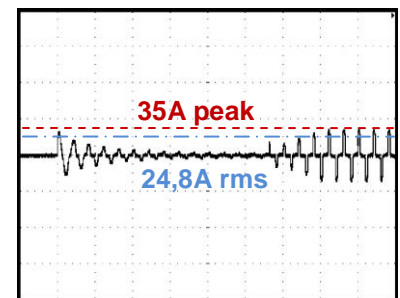

Identical with ESB00351

Design-In of ESB00351 into AC-Networks

The ESB00351 is an precise inrush current limiter with an overall tolerance of ±6% of the face value. For the dimension of an upstream connected circuit breaker the R.M.S is the key value of the inrush current, not the peak current. The thermal trigger point will not be met, even while using an extreme fast CB. All-dominant is the magnetic trigger current. By using the empirical formula $I_{(peak)} \times 0,707_{(factor)} = I_{(r.m.s.)}$ the tripping current can be defined fairly exact. Bear in mind that all the higher the inrush current is, all the faster the input capacitor of a number of connected switch mode power supplies will be loaded.

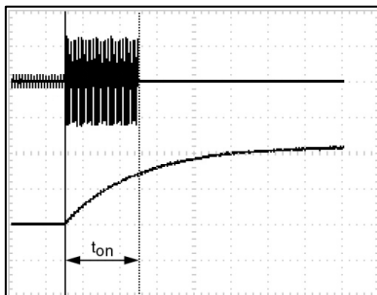

Limiting time effect

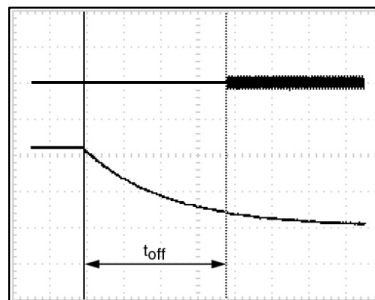

Low voltage detection Toff

	Customer chosen range Δt	Standard setup
Ton	150...300ms	150ms
Toff	100...150ms	100ms

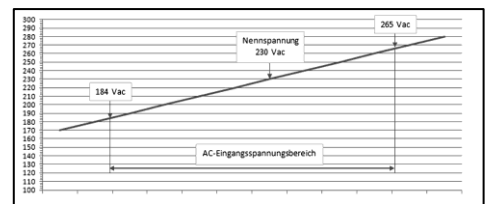

Low voltage detection $U < 184Vac / Toff > \Delta t$

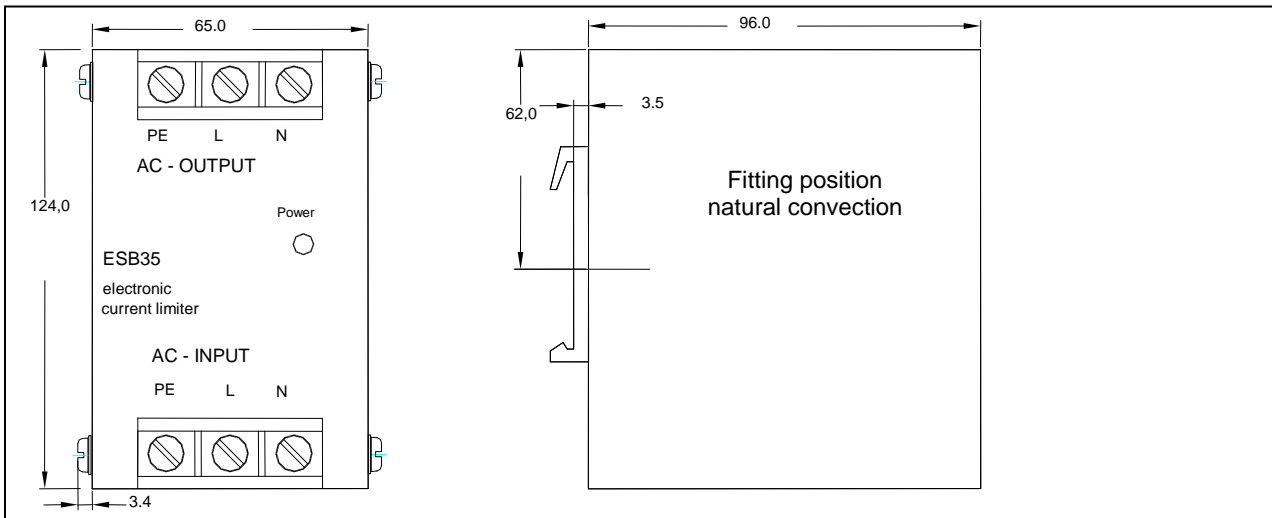

Mechanics:

IP20 DIN43880 metal housing with IEC standard ventilation holes. Save fit on DIN-Rail TS35mm DIN/EN60715.

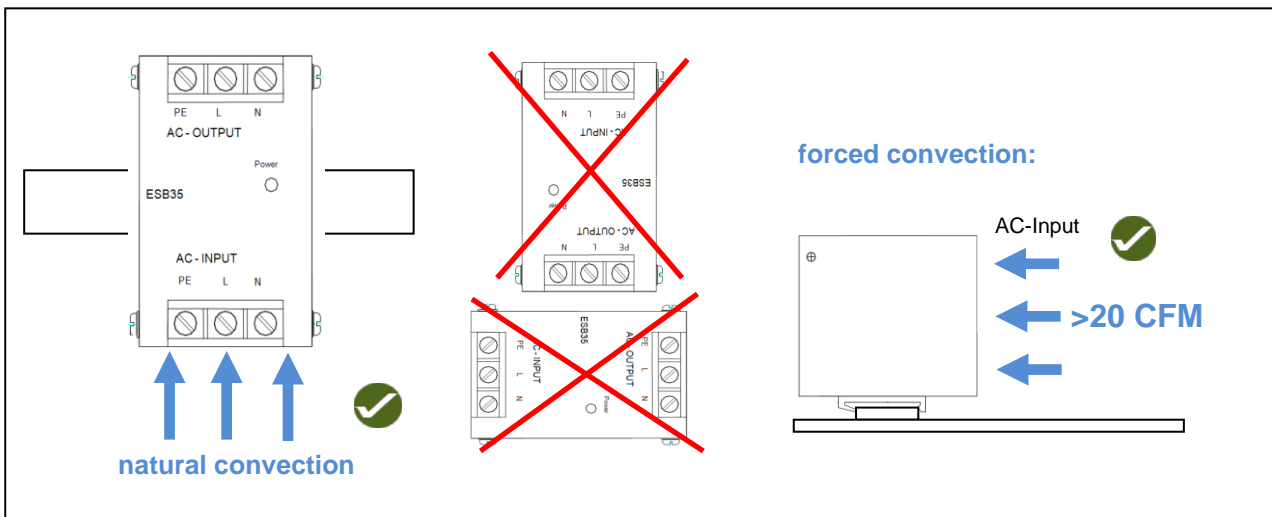

Einbaulage

Safety Instructions: Please read all warnings and advices carefully before installing or operating the ESB00351. Retain this operation manual always ready to hand. The ESB00351 must be installed by specialist staff only.

Installation:

- 1.) The ESB00351 is designed for systems fulfilling the safety norms of dangerous voltages/energy and fire prevention
- 2.) Installation is restricted to specialists only, make sure that the AC wire system is free of voltage
- 3.) Opening the ESB00351, making any modifications to it, dismantling any screws from it, operating the ESB out of specification and/or using it in appropriate area will inevitably result in loosing manufactureres guarantee; we decline taking any responsibility for risk of damages caused to someones health or to any installed system.

Warnings:

Disregard these warnings can cause fire, electric shock, serious accident and death.

1. Never operate the ESB without Protective Earth Conductor
2. Before connecting the ESB00351 to the AC wire system make all wires free of voltage and assure accidently switch on
3. Allow neat and professional cabling
4. Never open nor try to repair the ESB by yourself. Inside are dangerous voltages that can cause electric shock hazard.
5. Avoid metal pieces or other conductive material to fall into the ESB00351
6. Do not operate the ESB00351 under damp or wet conditions
7. It is forbidden to operate the ESB00351 under Ex conditions or in an Ex-Area

