



- External Maintenance Bypass Switch
- Single & Dual Input
- Electric Interlock
- Rack Mount / Wall Mounting Format
- 115 VAC & 230 VAC Versions

## Specification

### Input

- |               |   |
|---------------|---|
| Input Voltage | <ul style="list-style-type: none"> <li>• 115 V single phase, 80-138 V</li> <li>• 230 V single phase, 176-276 V</li> </ul> |
|---------------|---|

### Output

- |                   |   |
|-------------------|---|
| Output Voltage    | <ul style="list-style-type: none"> <li>• 115 V single phase, 80-138 V</li> <li>• 230 V single phase, 176-276 V</li> </ul> |
| Output Regulation | <ul style="list-style-type: none"> <li>• See Output Characteristics Table</li> </ul>                                      |

### General

- |                |  |
|----------------|--|
| Dimensions     | <ul style="list-style-type: none"> <li>• See Output Characteristics Table</li> </ul> |
| IP Rating      | <ul style="list-style-type: none"> <li>• IP30</li> </ul>                             |
| Connector Type | <ul style="list-style-type: none"> <li>• Contact Sales Team</li> </ul>               |

### Environmental

- |                       |  |
|-----------------------|--|
| Operating Temperature | <ul style="list-style-type: none"> <li>• 0 °C to +40 °C</li> </ul>               |
| Storage Temperature   | <ul style="list-style-type: none"> <li>• -10 °C to +85 °C</li> </ul>             |
| Operating Humidity    | <ul style="list-style-type: none"> <li>• &lt;0-95% RH, non-condensing</li> </ul> |
| Storage Humidity      | <ul style="list-style-type: none"> <li>• &lt;0-95% RH, non-condensing</li> </ul> |
| Operating Altitude    | <ul style="list-style-type: none"> <li>• 1000 metres</li> </ul>                  |
| Shock & Vibration     | <ul style="list-style-type: none"> <li>• &lt;2 g</li> </ul>                      |

### EMC & Safety

- |                  |  |
|------------------|--|
| Safety Standards | <ul style="list-style-type: none"> <li>• EN60947 1999 low voltage switchgear &amp; control gear</li> </ul> |
|------------------|--|

## Product Description

The External Maintenance Bypass Switch (EMBS) permits the maintenance or repair of a UPS system by providing a simple but efficient means of temporarily isolating/removing the UPS from the power circuit without interrupting power to the critical load.

All EMBS panels supplied by Powersolve are fitted with an electrical interlock to prevent the maintenance supply being accidentally connected in parallel with the UPS output. Service personnel are provided with a key operated over-ride switch to allow the maintenance bypass breaker to be closed once the UPS has been transferred to internal bypassmode, during normal maintenance of the system.

## Front Panel



Single Phase/Single Feed Input					
Rating	Voltage	Current	Format	Dimensions (H , W, D)	Model Number
1.5 kVA	230 V	10 A	19" Rack	2U x 19" x355mm	Xi BBSR 1k5
3.0 kVA	230 V	16 A	19" Rack	2U x 19" x355mm	Xi BBSR 3k
6.0 kVA	230 V	32 A	19" Rack	3U x 19" x355mm	Xi BBSR 6k
1.5 kVA	230 V	10 A	Wall	445 x 400 x100mm	Xi BBSW 1k5
3.0 kVA	230 V	16 A	Wall	445 x 400 x100mm	Xi BBSW 3k
6.0 kVA	230 V	32 A	Wall	530 x 400 x100mm	Xi BBSW 6k
1.5 kVA	115 V	16 A	19" Rack	2U x 19" x355mm	Xi BBSR 1k5 115V
3.0 kVA	115 V	32 A	19" Rack	3U x 19" x355mm	Xi BBSR 3k 115V
1.5 kVA	115 V	16 A	Wall	445 x 400 x100mm	Xi BBSW 1k5 115V
3.0 kVA	115 V	32 A	Wall	530 x 400 x100mm	Xi BBSW 3k 115V

Single Phase/Dual Feed Input					
Rating	Voltage	Current	Format	Dimensions (H , W, D)	Model Number
1.5 kVA	230 V	10 A	19" Rack	2U x 19" x355mm	Xi BB 1k5
3.0 kVA	230 V	16 A	19" Rack	2U x 19" x355mm	Xi BB 3k
6.0 kVA	230 V	32 A	19" Rack	3U x 19" x355mm	Xi BB 6k
1.5 kVA	230 V	10 A	Wall	445 x 400 x100mm	Xi BBW 1k5
3.0 kVA	230 V	16 A	Wall	445 x 400 x100mm	Xi BBW 3k
6.0 kVA	230 V	32 A	Wall	530 x 400 x100mm	Xi BBW 6k
1.5 kVA	115 V	16 A	19" Rack	2U x 19" x355mm	Xi BB 1k5 115V
3.0 kVA	115 V	32 A	19" Rack	3U x 19" x355mm	Xi BB 3k 115V
1.5 kVA	115 V	16 A	Wall	445 x 400 x100mm	Xi BBW 1k5 115V
3.0 kVA	115 V	32 A	Wall	530 x 400 x100mm	Xi BBW 3k 115V

### Single Phase / Single Feed Input

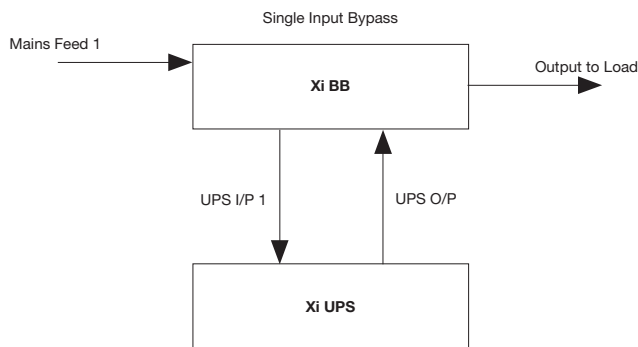

### Single Phase / Dual Feed Input

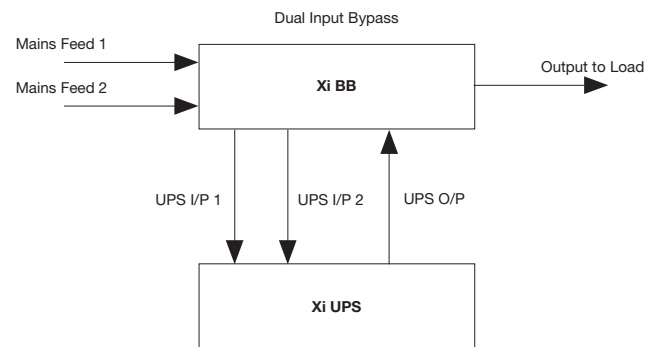

### Circuit Diagram

